

MF-30

– Mechanical Filter, wallmounted,
for two PlymoVent Ø 160 mm / 6.3" KUA/EA-arms

TECHNICAL DATA

Unit specification

Housing material: Galvanized steel
 Housing finish: Epoxy powder coat
 Unit weight: 49 kg / 108 lbs
 Unit dimensions: H: 857 mm / 33 3/4 inch
 W: 680 mm / 26 3/4 inch
 D: 763 mm / 30 inch
 Air volume: 2 x 800 - 1200 m³/h / 2 x 470 - 700 CFM
 Max. negative pressure: 4000 Pa / 16" wg
 Filter indicator: Manometer 0-2000 Pa / 0-8" wg

Filter elements:

Stage 1: Spark arrestor
 Stage 2: Pre-filter aluminium mesh
 Stage 3: Fine filter, glass fibre – GFMF
 95% ASHRAE/F9 EuroVent/BIA-C
 Final filter pressure: 800 Pa / 3.2" wg

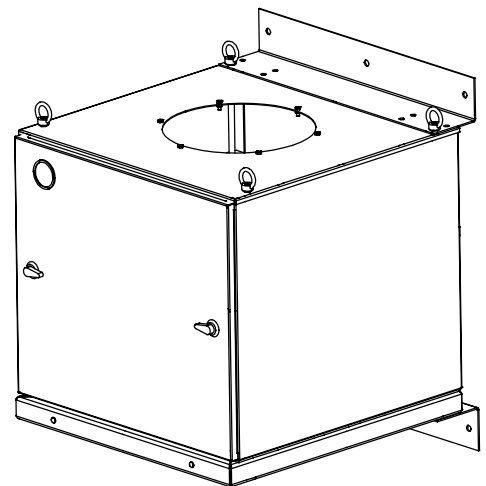

DIMENSIONAL DATA

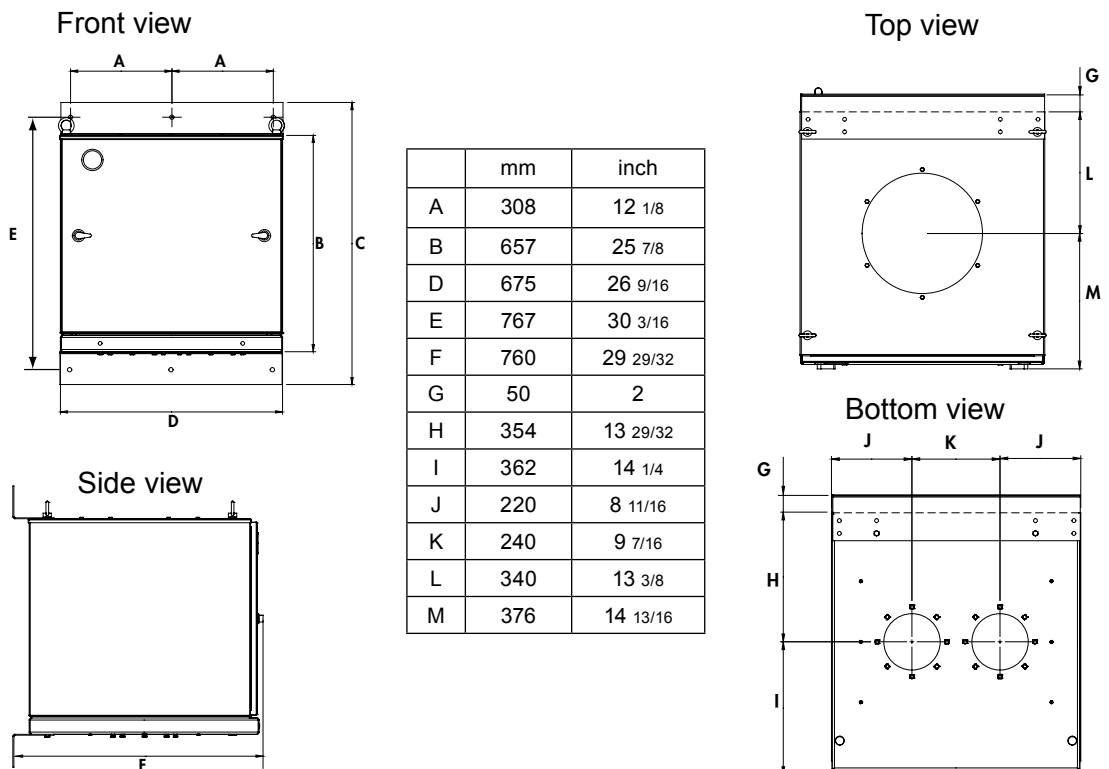

PlymoVent representative



PLYMOVENT®

PlymoVent AB
 Industrigatan 26,
 SE-212 14 Malmö, Sweden
 Tel: +46 40 30 31 30,
 Fax: +46 40 30 31 40
 www.plymovent.com
 info@plymovent.se

PlymoVent Ltd
 Marley Way, Southam Road, Banbury,
 Oxfordshire OX16 2RA, England
 Tel: (01295) 25 93 11,
 Fax: (01295) 27 17 50
 www.plymovent.co.uk
 info@plymovent.co.uk