

Push-Pull Welding Torch PP 240 D/401 D liquid cooled



BINZEL. The right welding torch for every job!

BINZEL welding torches incorporate the high quality and technology needed for trouble-free performance whatever the welding job. All BINZEL torches are constructed to the highest standards and offer the greatest working comfort.

Thanks to a supplementary pull motor in the handle, PUSH-PULL welding torches guarantee constant and problem-free wire feeding. Push-pull guns are ideally suited for hard-to-feed wire like aluminium, thin wire and for extended cable assemblies that allow welding at longer distances from the wire

Technical data (EN 50 078):

PP 240 D / PP 401 D

Rating: 300 A / 400 A CO₂
270 A / 350 A Mixed Gases M 21 (DIN EN 439)
100% Duty Cycle

Wire sizes: 0.8 - 1.2 / 0.8 - 1.6

drive unit. PUSH-PULL torches have become the industry standard in shipbuilding, container and tank manufacture, and are also used extensively in the construction of automobiles, railroad cars and rolling stock.

Rated using power source with VDE standard volt/amp characteristic ($U=14+0,05xI$). When pulse welding, reduce rating by 35%. Recommended cooling capacity of coolant recirculator ca. 800 W.

Type	Version	Motor	Cable length	Part no.
PP 240 D	straight	42 V	8.00 m	092.0018
	45° bent	42 V	8.00 m	092.0019
PP 401 D	straight	42 V	8.00 m	091.0043
	45° bent	42 V	8.00 m	091.0044

Welding & cutting brought to the point.



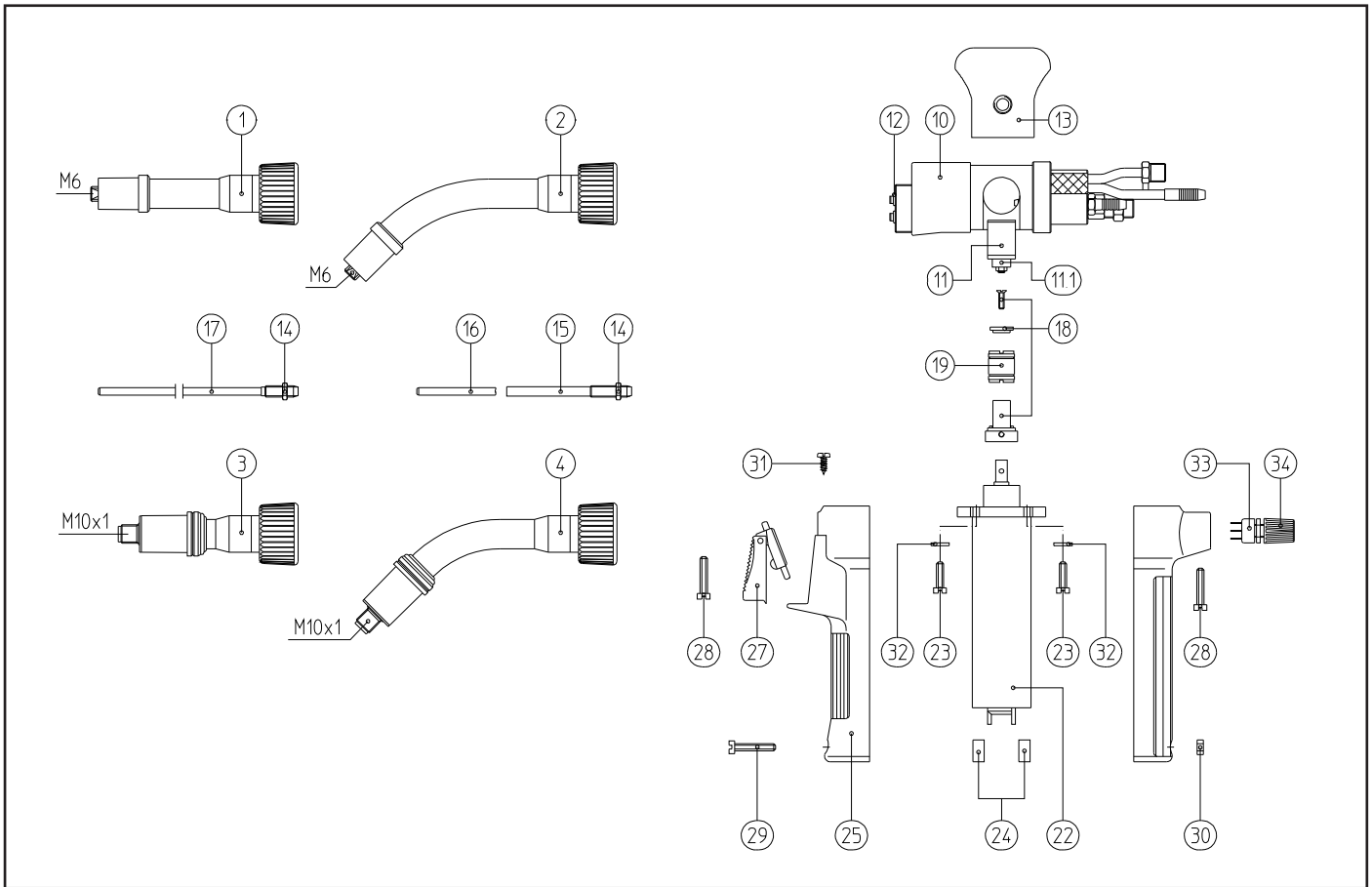

Build group	Pos.	Description	Specifications	Part no.
Swan neck	1	Straight neck PP 240 D		092.0007
	2	Swan neck PP 240 D, 45° bent		092.0001
	3	Straight neck PP 401 D		091.0002
	4	Swan neck PP 401 D, 45° bent		091.0001
Torch body, gear motor and accessories	10	Torch body PPW cpl.		091.0003
	11	Idler arm cpl.		080.0007
	11.1	Pressure roll		080.0042
	12	O-ring 3x1.5	20 pcs.	165.0054
	13	Drive roll cap cpl.		080.0003
		Pressure spring		080.0032
		Ball		080.0043
		Drive roll cap		080.0005
		Knob for drive roll cap		080.0006
	14	Lock nut M6	20 pcs.	081.0018
	15	Wire guide for bent neck 60.0 mm long		081.0016
	16	Brass-liner CuZn 37; 1.8/4.4 (up to wire Ø 1.2)	per meter	120.0018
		Brass-liner CuZn 37; 2.2/4.4 (up to wire Ø 1.6)	per meter	120.0041
	17	Wire guide for straight neck 148.0 mm long		081.0017
	18	Drive roll seat cpl.		080.0004
	19	Wire drive roll, for wire Ø 0.8 mm		080.0019
		Wire drive roll, for wire Ø 1.0 mm		080.0021
		Wire drive roll, for wire Ø 1.2 mm		080.0022
		Wire drive roll, for wire Ø 1.4 mm		080.0025
		Wire drive roll, for wire Ø 1.6 mm		080.0023
	22	Gear motor 42 V with flange for wire drive roll		080.0010
		Gear motor 24 V with flange for wire drive roll		080.0092
	w/o. fig. Transformer prim. 24 V / sec. 36 V		080.0045	
	w/o. fig. Transformer prim. 110 V / sec. 36 V		080.0055	

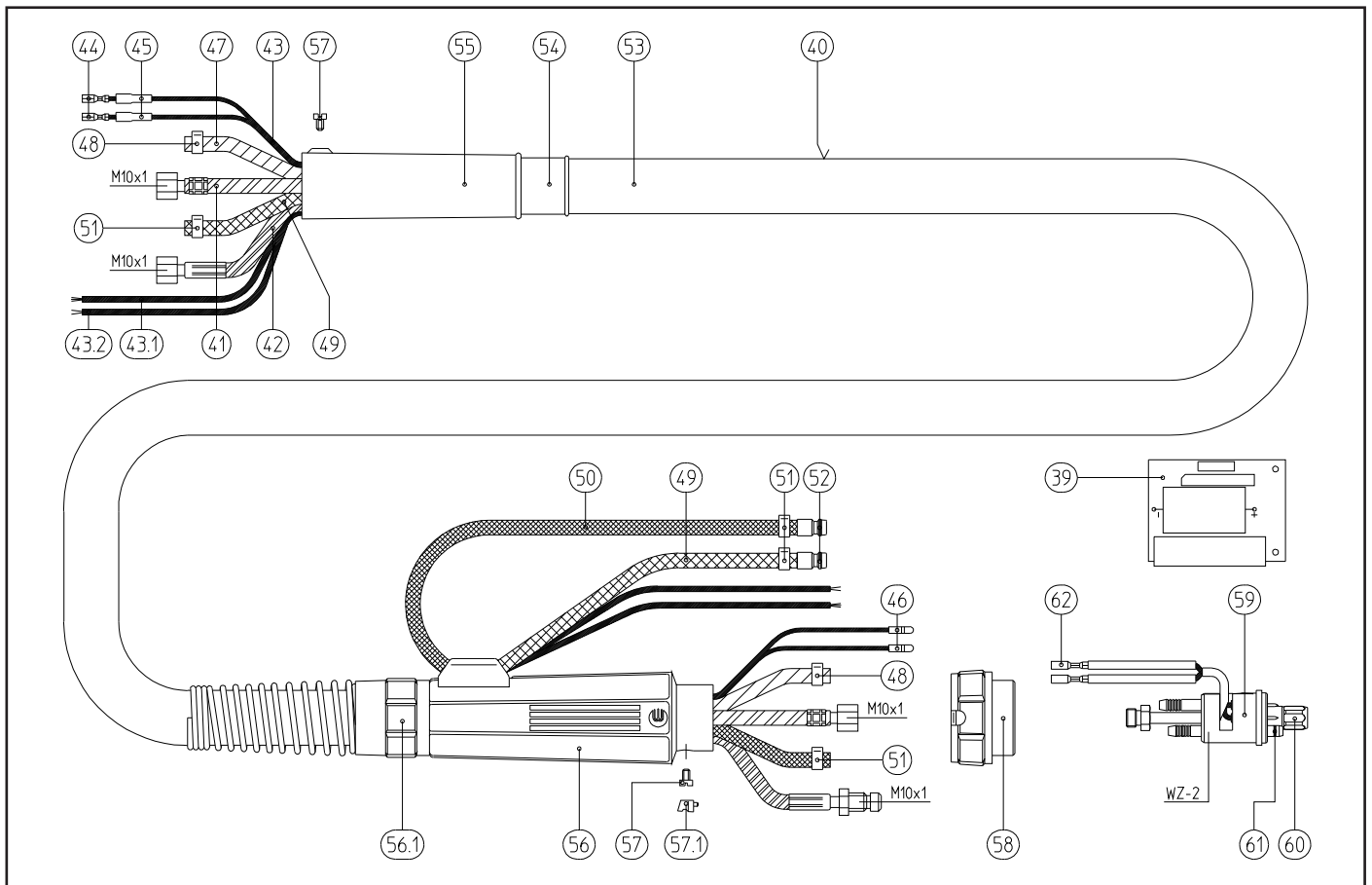

Build group	Pos.	Description	Specifications	Part no.
	23	Screw M3x10	20 pcs.	000.0543
	24	Brushes for gear motor		080.0046
Handle	25	Handle		080.0096
	27	Trigger 2 pol.		185.0005
	28	Screw M3x20	20 pcs.	000.0548
	29	Screw M4x25	20 pcs.	000.0560
	30	Hexagon nut M4	20 pcs.	009.0172
	31	Screw 2.9x6.5	20 pcs.	079.0003
	32	Ring	20 pcs.	001.0271
	33	Potentiometer 2.2 K Ω		187.0006
		Potentiometer 4.7 K Ω		187.0003
		Potentiometer 10.0 K Ω		187.0004
	34	Potentiometer knob		400.0108
Circuit board	39	Printed circuit board for 42 V motor		080.0009
Cable assembly	40	Cable assembly, cpl. 8.00 m with 7-pol. control leads without central connector WZ-2		090.0026
	41	Power cable g/w-cooled	for 8.00 m	115.0328
	42	Wire conduit cpl.	for 8.00 m	153.0028
	43	Control cable 2 pol.	per meter	100.0019
	43.1	Control cable 3 pol.	per meter	100.0023
	43.2	Control cable 2 pol.	per meter	100.0123
	44	Trigger wire connector	20 pcs.	175.0022
	45	Insulating sleeve	20 pcs.	400.0119
	46	Trigger wire connector, male	20 pcs.	175.0004
	47	Hose 30 black \varnothing 4.9x1.5	per meter	109.0040
	48	Hose clamp \varnothing 8.7 mm	20 pcs.	171.0002
	49	Hose 47 blue \varnothing 5.5x1.5	per meter	109.0057

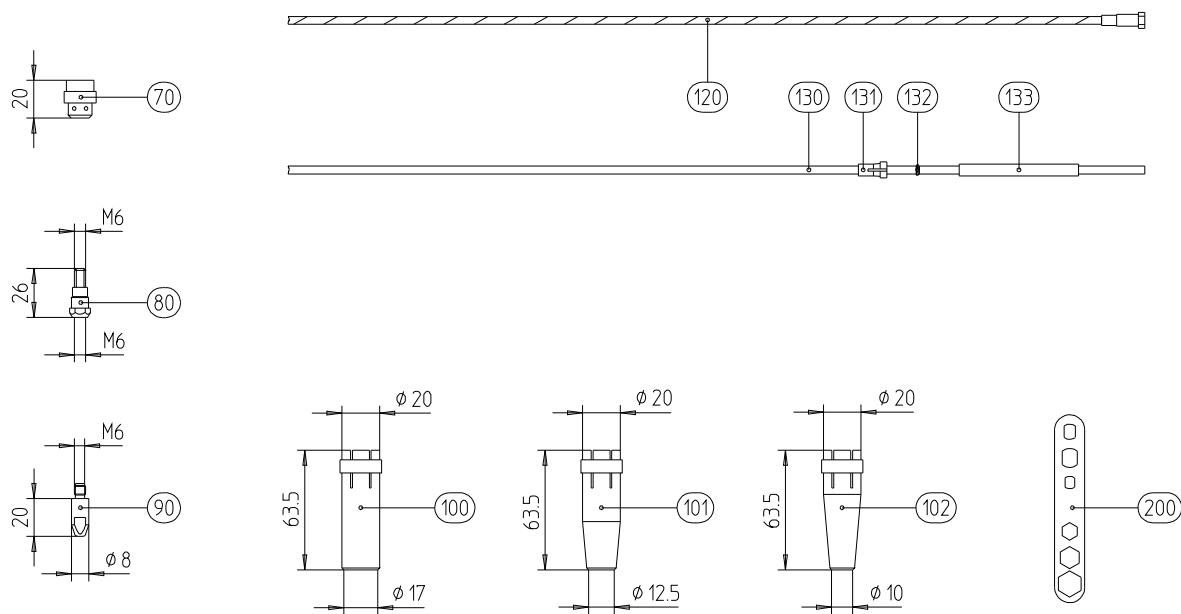

Build group	Pos.	Description	Specifications	Part no.
Cable assembly	50	Hose 46 red Ø 5.5x1.5 cpl. with Quick connector	0.5 m	103.0108
	51	Hose clamp Ø 9.5 mm with ring	20 pcs.	173.0001
	52	Quick connector	20 pcs.	501.0114
	53	Outer cover Ø 25x1.5	per meter	107.0004
	54	Cable support torch side		400.0189
	55	Cable support		090.0003
	56	Cable support machine side		500.0342
	56.1	Connecting set machine side NW 29		501.2236
	57	Screw M4x6	20 pcs.	000.0552
	57.1	Covering cap	20 pcs.	500.0251
	58	Adaptor nut		500.0213
	59	Central adaptor block WZ-2		501.0015
	60	Nut M10x1	10 pcs.	501.0082
	61	O-ring 4x1	20 pcs.	165.0002
62	Trigger wire connector, female	20 pcs.	175.0003	
Wear parts	70	Gas diffuser for PP 240 D black	• 10 pcs.	012.0017
		Gas diffuser for PP 240 D white	10 pcs.	012.0183
	71	Gas diffuser for PP 401 D black	Δ 10 pcs.	030.0029
		Gas diffuser for PP 401 D white	10 pcs.	030.0145
	80	Contact tip holder M6, 26.0 mm PP 240 D	• 10 pcs.	142.0003
	81	Contact tip holder M6, 25.0 mm (short) PP 401 D	10 pcs.	142.0008
	82	Contact tip holder M6, 29.0 mm (long) PP 401 D	10 pcs.	142.0013
	83	Contact tip holder M8, 25.0 mm (short) PP 401 D	Δ 10 pcs.	142.0022
	84	Contact tip holder M8, 29.0 mm (long) PP 401 D	10 pcs.	142.0027
	90	Contact tip M6 E-Cu, Ø 0.8	10 pcs.	140.0051
		Contact tip M6 E-Cu, Ø 1.0	• 10 pcs.	140.0242
		Contact tip M6 E-Cu, Ø 1.2	10 pcs.	140.0379
		Contact tip M6 E-Cu, Ø 1.4	10 pcs.	140.0516
		Contact tip M6 E-Cu, Ø 1.6	10 pcs.	140.0555

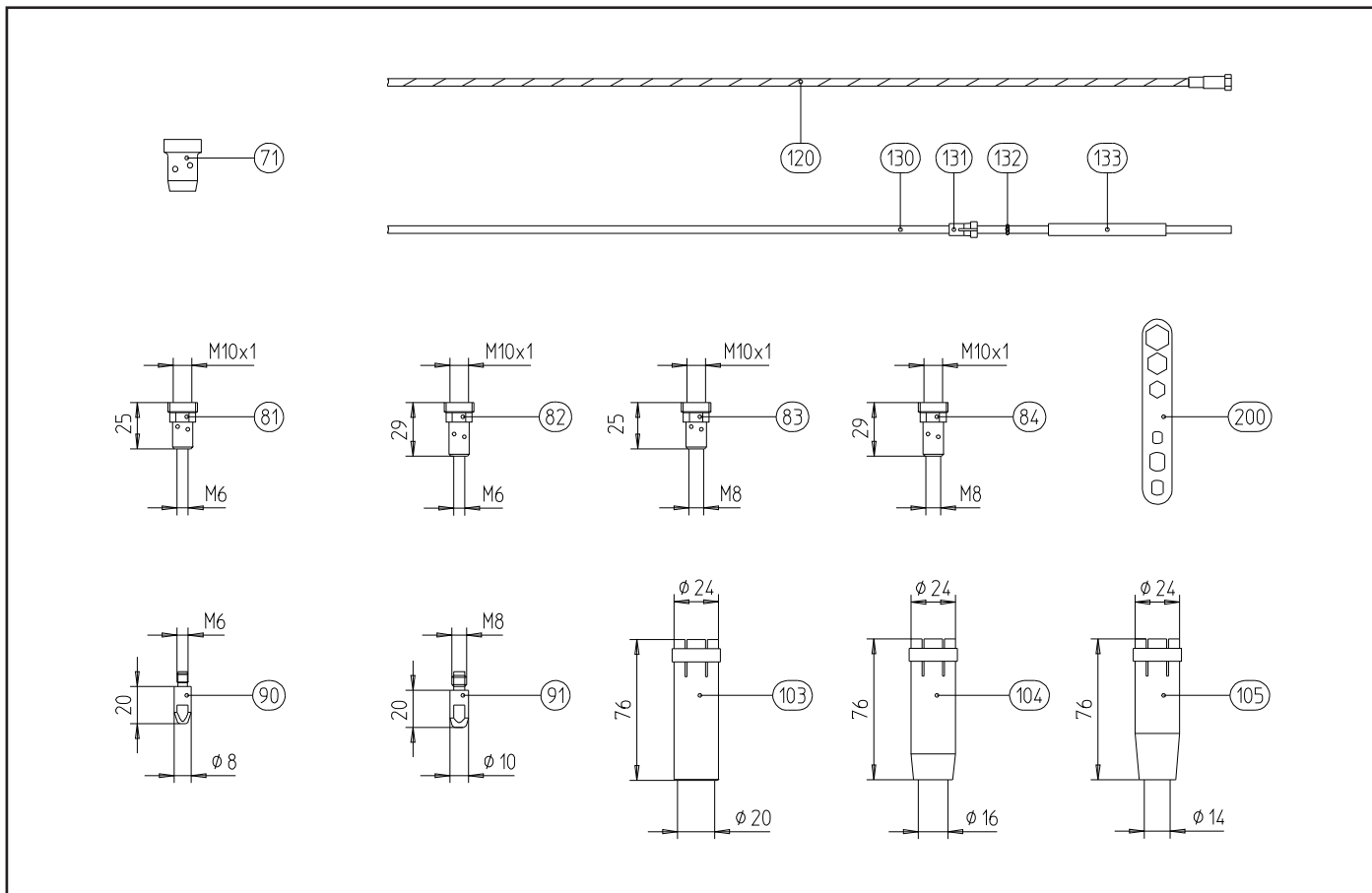

Build group	Pos.	Description	Specifications	Part no.
Wear parts		Contact tip M6 CuCrZr, Ø 0.8	10 pcs.	140.0054
		Contact tip M6 CuCrZr, Ø 1.0	10 pcs.	140.0245
		Contact tip M6 CuCrZr, Ø 1.2	10 pcs.	140.0382
		Contact tip M6 CuCrZr, Ø 1.4	10 pcs.	140.0519
		Contact tip M6 CuCrZr, Ø 1.6	10 pcs.	140.0558
		Contact tip M6 E-Cu, Ø 0.8 for alu wire	10 pcs.	141.0001
		Contact tip M6 E-Cu, Ø 1.0 for alu wire	10 pcs.	141.0006
		Contact tip M6 E-Cu, Ø 1.2 for alu wire	10 pcs.	141.0010
		Contact tip M6 E-Cu, Ø 1.6 for alu wire	10 pcs.	141.0020
	91	Contact tip M8 E-Cu, Ø 0.8	10 pcs.	140.0114
		Contact tip M8 E-Cu, Ø 1.0	10 pcs.	140.0313
		Contact tip M8 E-Cu, Ø 1.2	Δ 10 pcs.	140.0442
		Contact tip M8 E-Cu, Ø 1.4	10 pcs.	140.0533
		Contact tip M8 E-Cu, Ø 1.6	10 pcs.	140.0587
		Contact tip M8 CuCrZr, Ø 0.8	10 pcs.	140.0117
		Contact tip M8 CuCrZr, Ø 1.0	10 pcs.	140.0316
		Contact tip M8 CuCrZr, Ø 1.2	10 pcs.	140.0445
		Contact tip M8 CuCrZr, Ø 1.4	10 pcs.	140.0536
		Contact tip M8 CuCrZr, Ø 1.6	10 pcs.	140.0590
	Contact tip M8 E-Cu, Ø 0.8 for alu wire	10 pcs.	141.0003	
	Contact tip M8 E-Cu, Ø 1.0 for alu wire	10 pcs.	141.0008	
	Contact tip M8 E-Cu, Ø 1.2 for alu wire	10 pcs.	141.0015	
	Contact tip M8 E-Cu, Ø 1.6 for alu wire	10 pcs.	141.0022	
100	Gas nozzle, cylindrical ND Ø 17.0 for PP 240 D	• 10 pcs.	145.0047	
101	Gas nozzle, conical ND Ø 12.5 for PP 240 D	• 10 pcs.	145.0080	
102	Gas nozzle, tapered ND Ø 10.0 for PP 240 D	• 10 pcs.	145.0128	
103	Gas nozzle, cylindrical ND Ø 20.0 for PP 401 D	• 10 pcs.	145.0051	
104	Gas nozzle, conical ND Ø 16.0 for PP 401 D	Δ 10 pcs.	145.0085	
105	Gas nozzle, tapered ND Ø 14.0 for PP 401 D	• 10 pcs.	145.0132	

Build group	Pos.	Description	Specifications	Part no.
Wear parts	120	Guide spiral liner blank 1.5/4.0 with nipple for wire electrode ¹⁾ Ø 0.6-0.9	for 8.00 m	122.0010
		Guide spiral liner blank 2.0/4.5 with nipple for wire electrode ¹⁾ Ø 1.0-1.2	for 8.00 m	122.0040
		Guide spiral liner blank 2.5/4.5 with nipple for wire electrode ¹⁾ Ø 1.4-1.6	for 8.00 m	122.0065
	130	Teflon core liner 1.5/4.0 blue with collet and o-ring for wire electrode ²⁾ Ø 0.6-1.0	for 8.00 m	126.0013
		Teflon core liner 2.0/4.0 red with collet and o-ring for wire electrode ²⁾ Ø 1.0-1.4	for 8.00 m	126.0030
		Teflon core liner 2.7/4.7 yellow with collet and o-ring for wire electrode ²⁾ Ø 1.6	for 8.00 m	126.0047
		Teflon carbon core liner 1.5/4.0 with collet and o-ring for wire electrode ²⁾ Ø 0.6-1.0	for 8.00 m	127.0015
		Teflon carbon core liner 2.0/4.0 with collet and o-ring for wire electrode ²⁾ Ø 1.0-1.4	for 8.00 m	127.0009
		Teflon carbon core liner 2.7/4.7 with collet and o-ring for wire electrode ²⁾ Ø 1.6	for 8.00 m	127.0014
		Polyamid core liner ³⁾ 2.0/4.0 with collet and o-ring for wire electrode ²⁾ Ø 1.0-1.4	• Δ for 8.00 m	128.0019
		Polyamid core liner ³⁾ 2.3/4.7 with collet and o-ring for wire electrode ²⁾ Ø 1.6	for 8.00 m	128.0023
	131	Collet for core liner Ø 4.0	20 pcs.	131.0001
		Collet for core liner Ø 4.7	20 pcs.	131.0002
	132	O-ring 3.5x1.5	20 pcs.	165.0008
	133	Guide tube for core liners up to Ø 4.0	200 mm	129.0461
		Guide tube for core liners up to Ø 4.0	300 mm	129.0471
	200	Spanner	10 pcs.	191.0001

¹⁾ Applicable for GMA welding of unalloyed and low-alloyed steels (DIN 8555 and 8559).

²⁾ Applicable for GMA welding of aluminium (DIN 1732), copper and copper alloys (DIN 1733) and nickel/nickel alloys (DIN 1736); Also for use with GMA welding of stainless and heat resistant steels (DIN 8556).

³⁾ Applicable up to max. 150° C.

• Standard - Equipment PP 240 D

Δ Standard - Equipment PP 401 D

When ordering goods sold by the meter, please refer to your dealer for details on roll length.

Welding & cutting brought to the point.



Alexander Binzel Schweißtechnik GmbH & Co. KG
P.O. Box 10 01 53 · D-35331 Gießen
Tel.: ++49 (0) 64 08 / 59-0
Fax: ++49 (0) 64 08 / 59-191
Internet: <http://www.binzel-abicor.com>