



Barcode: 5060452080178

barrobox™

Product code: BB2

- » Unique mobile site box, designed for workers on the move.
- » Retractable wheels instantly convert the box from mobile to static.
- » Unique external and internal anti-jemmy systems for added security.



Watch the BarroBox in action

Product features



2x 5-lever deadlock



Gas strut (300N)



SlamStop lid stay



Puncture-proof tyres



Forklift skids



No detachable parts



Suitable for site



Built in handles

Product specifications

Weight	81kg
Colour	Black grey: RAL 7021, Traffic red: RAL 3020
Suitable for	Site
Finished coating	Powder coated
Material & thickness	1.5mm body and 2mm lid steel
Quantity of keys	3 keys
Suitable for vehicle mounting	No
How are castors fitted?	Not applicable
Other sizes available	No
Qty of shelves as standard	No

Dimensions

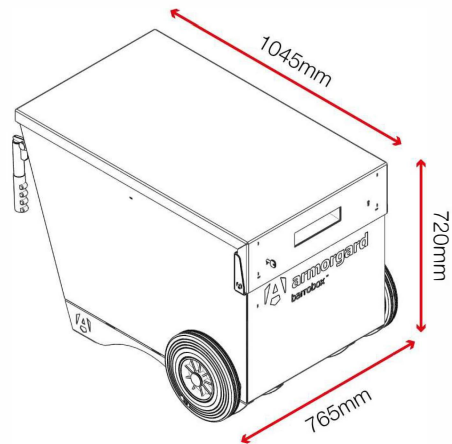

Related products



TuffBank TB2



TuffBank TB21



OxBox OX3



TrekDror TKD1

