



Barcode: 5060452081199

# drumbank™

Product code: DB2

- » Enclosed safe storage for drums and other hazardous goods.
- » Fully welded sump with removable steel grid flooring.
- » Wide opening doors and lift up lid for ease of access.



## Product features



5-lever deadlock



Gas strut (300N)



Forklift skids



COSHH compliant



Sump capacity 295L



Fire resistant



Safety signage

## Product specifications

Weight	178kg
Colour	Gentian blue: RAL 5010
Suitable for	Outdoor storage of drums - 2 x 205L
Finished coating	Powder coated
Material & thickness	2mm steel
Quantity of keys	2 keys
How are castors fitted?	Not applicable
Other sizes available	1 other size
Ventilation	Yes
Qty of shelves as standard	Not applicable

## Dimensions

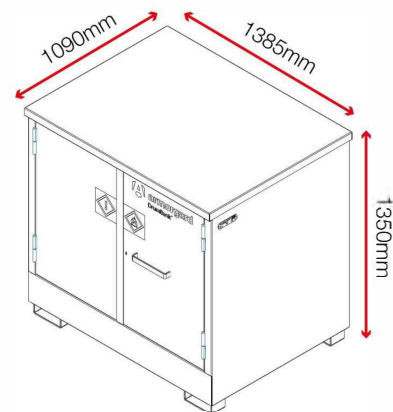

## Related products



DrumBank DB4



DrumBank DBP2



DrumBank DB2S

