



Barcode: 5060452081212

drumbank™ pallet

Product code: DBP2

- » Forkliftable sump pallet for drums and other hazardous goods.
- » Extra tough PVC construction.
- » Designed for storing up to 2 x 205 litre drums.



Product features



Forklift pockets



COSHH compliant



Safety signage



Sump capacity

Product specifications

Weight	20kg
Colour	Black
Suitable for	Outdoor storage of drums - 2 x 205L
Material & thickness	PVC
How are castors fitted?	Not applicable
Other sizes available	1 other size
Ventilation	No
Qty of shelves as standard	Not applicable

Dimensions

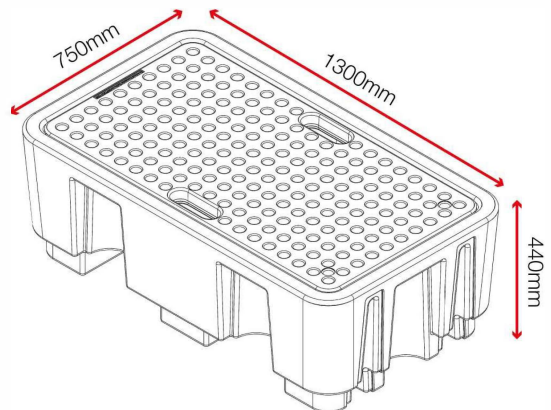

Related products



DrumBank DBP4



DrumBank DB2



DrumBank DB2S

