



EN

Welding machine

**Picomig 225 puls TKG
Picomig 225 Synergic TKG**

099-005682-EW501

Observe additional system documents!

7.9.2022

**Register now
and benefit!
Jetzt Registrieren
und Profitieren!**

www.ewm-group.com



General instructions

WARNING



Read the operating instructions!

The operating instructions provide an introduction to the safe use of the products.

- Read and observe the operating instructions for all system components, especially the safety instructions and warning notices!
- Observe the accident prevention regulations and any regional regulations!
- The operating instructions must be kept at the location where the machine is operated.
- Safety and warning labels on the machine indicate any possible risks. Keep these labels clean and legible at all times.
- The machine has been constructed to state-of-the-art standards in line with any applicable regulations and industrial standards. Only trained personnel may operate, service and repair the machine.
- Technical changes due to further development in machine technology may lead to a differing welding behaviour.

In the event of queries on installation, commissioning, operation or special conditions at the installation site, or on usage, please contact your sales partner or our customer service department on +49 2680 181-0.

A list of authorised sales partners can be found at www.ewm-group.com/en/specialist-dealers.

Liability relating to the operation of this equipment is restricted solely to the function of the equipment. No other form of liability, regardless of type, shall be accepted. This exclusion of liability shall be deemed accepted by the user on commissioning the equipment.

The manufacturer is unable to monitor whether or not these instructions or the conditions and methods are observed during installation, operation, usage and maintenance of the equipment.

An incorrectly performed installation can result in material damage and injure persons as a result. For this reason, we do not accept any responsibility or liability for losses, damages or costs arising from incorrect installation, improper operation or incorrect usage and maintenance or any actions connected to this in any way.

© EWM AG

Dr. Günter-Henle-Strasse 8
56271 Mündersbach Germany
Tel.: +49 2680 181-0, Fax: -244
Email: info@ewm-group.com

www.ewm-group.com

The copyright to this document remains the property of the manufacturer.

Copying, including extracts, only permitted with written approval.

The content of this document has been prepared and reviewed with all reasonable care. The information provided is subject to change; errors excepted.

Data security

The user is responsible for backing up data of all changes from the factory setting. The user is liable for erased personal settings. The manufacturer does not assume any liability for this.

1 Contents

1	Contents.....	3
2	For your safety.....	5
2.1	Notes on using these operating instructions	5
2.2	Explanation of icons	6
2.3	Safety instructions.....	7
2.4	Transport and installation	10
3	Intended use.....	12
3.1	Applications.....	12
3.1.1	Picomig 225 puls TKG.....	12
3.1.2	Picomig 225 Synergic TKG	12
3.2	Documents which also apply.....	12
3.2.1	Warranty.....	12
3.2.2	Declaration of Conformity.....	12
3.2.3	Welding in environments with increased electrical hazards.....	12
3.2.4	Service documents (spare parts and circuit diagrams).....	12
3.2.5	Calibration/Validation	12
3.2.6	Part of the complete documentation.....	13
4	Machine description – quick overview.....	14
4.1	Front view / rear view.....	14
4.2	Inside view.....	16
5	Design and function.....	17
5.1	Transport and installation	17
5.1.1	Ambient conditions	17
5.1.2	Machine cooling	18
5.1.3	Workpiece lead, general.....	18
5.1.4	Notes on the installation of welding current leads.....	19
5.1.5	Stray welding currents.....	20
5.1.6	Welding torch holder	21
5.1.7	Mains connection.....	22
5.1.7.1	Mains configuration.....	22
5.1.8	Shielding gas supply (shielding gas cylinder for welding machine).....	23
5.1.8.1	Pressure regulator connection.....	23
5.1.8.2	Shielding gas hose connection.....	24
5.1.8.3	Gas test – setting the shielding gas volume.....	24
5.1.9	Dirt filter.....	24
5.2	MIG/MAG welding.....	25
5.2.1	Welding torch and workpiece line connection.....	25
5.2.2	Wire feed.....	26
5.2.2.1	Inserting the wire spool	26
5.2.2.2	Changing the wire feed rollers	27
5.2.2.3	Inching the wire electrode.....	30
5.2.2.4	Spool brake setting.....	31
5.2.3	Welding task selection.....	31
5.3	MMA welding.....	32
5.3.1	Connecting the electrode holder and workpiece lead.....	32
5.3.2	Welding task selection.....	32
5.4	TIG welding.....	33
5.4.1	Preparing the TIG welding torch.....	33
5.4.2	Welding torch and workpiece line connection.....	33
5.4.3	Welding task selection.....	33
6	Maintenance, care and disposal.....	34
6.1	General.....	34
6.2	Explanation of icons	35
6.3	Maintenance schedule.....	35
6.4	Disposing of equipment.....	37
7	Rectifying faults.....	38
7.1	Software version of the machine control	38

7.2	Error messages (power source).....	38
7.3	Checklist for rectifying faults	39
7.4	Dynamic power adjustment.....	40
7.5	Resetting welding parameters to the factory settings	41
8	Technical data	42
8.1	Picomig 225.....	42
9	Accessories.....	43
9.1	Transport system	43
9.2	Options.....	43
9.3	General accessories.....	43
10	Replaceable parts	44
10.1	Wire feed rollers.....	44
10.1.1	Wire feed rollers for steel wire.....	44
10.1.2	Wire feed rollers for aluminium wire.....	44
10.1.3	Wire feed rollers for cored wire	45
10.1.4	Wire guide.....	45
11	Appendix.....	46
11.1	Searching for a dealer.....	46

2 For your safety

2.1 Notes on using these operating instructions

DANGER

Working or operating procedures which must be closely observed to prevent imminent serious and even fatal injuries.

- Safety notes include the "DANGER" keyword in the heading with a general warning symbol.
- The hazard is also highlighted using a symbol on the edge of the page.

WARNING

Working or operating procedures which must be closely observed to prevent serious and even fatal injuries.

- Safety notes include the "WARNING" keyword in the heading with a general warning symbol.
- The hazard is also highlighted using a symbol in the page margin.

CAUTION

Working or operating procedures which must be closely observed to prevent possible minor personal injury.

- The safety information includes the "CAUTION" keyword in its heading with a general warning symbol.
- The risk is explained using a symbol on the edge of the page.



Technical aspects which the user must observe to avoid material or equipment damage.

Instructions and lists detailing step-by-step actions for given situations can be recognised via bullet points, e.g.:

- Insert the welding current lead socket into the relevant socket and lock.

2.2 Explanation of icons

Symbol	Description	Symbol	Description
	Indicates technical aspects which the user must observe.		Activate and release / Tap / Tip
	Switch off machine		Release
	Switch on machine		Press and hold
	Incorrect / Invalid		Switch
	Correct / Valid		Turn
	Input		Numerical value – adjustable
	Navigation		Signal light lights up in green
	Output		Signal light flashes green
	Time representation (e.g.: wait 4 s / actuate)		Signal light lights up in red
	Interruption in the menu display (other setting options possible)		Signal light flashes red
	Tool not required/do not use		Signal light lights up in blue
	Tool required/use		Signal light flashes blue

2.3 Safety instructions

WARNING



Risk of accidents due to non-compliance with the safety instructions!
Non-compliance with the safety instructions can be fatal!

- Carefully read the safety instructions in this manual!
- Observe the accident prevention regulations and any regional regulations!
- Inform persons in the working area that they must comply with the regulations!



Risk of injury from electrical voltage!

Voltages can cause potentially fatal electric shocks and burns on contact. Even low voltages can cause a shock and lead to accidents.

- Never touch live components such as welding current sockets or stick, tungsten or wire electrodes!
- Always place torches and electrode holders on an insulated surface!
- Wear the full personal protective equipment (depending on the application)!
- The machine may only be opened by qualified personnel!
- The device must not be used to defrost pipes!



Hazard when interconnecting multiple power sources!

If a number of power sources are to be connected in parallel or in series, only a technical specialist may interconnect the sources as per standard IEC 60974-9:2010: Installation and use and German Accident Prevention Regulation BVG D1 (formerly VBG 15) or country-specific regulations.

Before commencing arc welding, a test must verify that the equipment cannot exceed the maximum permitted open circuit voltage.

- Only qualified personnel may connect the machine.
- When taking individual power sources out of operation, all mains and welding current leads must be safely disconnected from the welding system as a whole. (Hazard due to reverse polarity voltage!)
- Do not interconnect welding machines with pole reversing switch (PWS series) or machines for AC welding since a minor error in operation can cause the welding voltages to be combined, which is not permitted.



Risk of injury due to radiation or heat!

Arc radiation can lead to skin and eye injuries.

Contact with hot workpieces and sparks can lead to burns.

- Use hand shield or welding helmet with the appropriate safety level (depends on the application).
- Wear dry protective clothing (e.g. hand shield, gloves, etc.) in accordance with the applicable regulations of your country.
- Persons who are not directly involved should be protected with a welding curtain or suitable safety screen against radiation and the risk of blinding!

WARNING

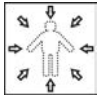

Risk of injury due to improper clothing!

During arc welding, radiation, heat and voltage are sources of risk that cannot be avoided. The user has to be equipped with the complete personal protective equipment at all times. The protective equipment has to include:

- Respiratory protection against hazardous substances and mixtures (fumes and vapours); otherwise implement suitable measures such as extraction facilities.
- Welding helmet with proper protection against ionizing radiation (IR and UV radiation) and heat.
- Dry welding clothing (shoes, gloves and body protection) to protect against warm environments with conditions comparable to ambient temperatures of 100 °C or higher and arcing and work on live components.
- Hearing protection against harming noise.



Explosion risk!

Apparently harmless substances in closed containers may generate excessive pressure when heated.

- Move containers with inflammable or explosive liquids away from the working area!
- Never heat explosive liquids, dusts or gases by welding or cutting!



Fire hazard!

Due to the high temperatures, sparks, glowing parts and hot slag that occur during welding, there is a risk of flames.

- Be watchful of potential sources of fire in the working area!
- Do not carry any easily inflammable objects, e.g. matches or lighters.
- Ensure suitable fire extinguishers are available in the working area!
- Thoroughly remove any residue of flammable materials from the workpiece prior to starting to weld.
- Only further process workpieces after they have cooled down. Do not allow them to contact any flammable materials!

⚠ CAUTION**Smoke and gases!**

Smoke and gases can lead to breathing difficulties and poisoning. In addition, solvent vapour (chlorinated hydrocarbon) may be converted into poisonous phosgene due to the ultraviolet radiation of the arc!

- Ensure that there is sufficient fresh air!
- Keep solvent vapour away from the arc beam field!
- Wear suitable breathing apparatus if appropriate!

**Noise exposure!**

Noise exceeding 70 dBA can cause permanent hearing damage!

- Wear suitable ear protection!
- Persons located within the working area must wear suitable ear protection!



According to IEC 60974-10, welding machines are divided into two classes of electromagnetic compatibility (the EMC class can be found in the Technical data) > see 8 chapter:



Class A machines are not intended for use in residential areas where the power supply comes from the low-voltage public mains network. When ensuring the electromagnetic compatibility of class A machines, difficulties can arise in these areas due to interference not only in the supply lines but also in the form of radiated interference.



Class B machines fulfil the EMC requirements in industrial as well as residential areas, including residential areas connected to the low-voltage public mains network.

Setting up and operating

When operating arc welding systems, in some cases, electro-magnetic interference can occur although all of the welding machines comply with the emission limits specified in the standard. The user is responsible for any interference caused by welding.

In order to **evaluate** any possible problems with electromagnetic compatibility in the surrounding area, the user must consider the following: (see also EN 60974-10 Appendix A)

- Mains, control, signal and telecommunication lines
- Radios and televisions
- Computers and other control systems
- Safety equipment
- The health of neighbouring persons, especially if they have a pacemaker or wear a hearing aid
- Calibration and measuring equipment
- The immunity to interference of other equipment in the surrounding area
- The time of day at which the welding work must be carried out

Recommendations for reducing interference emission

- Mains connection, e.g. additional mains filter or shielding with a metal tube
- Maintenance of the arc welding system
- Welding leads should be as short as possible and run closely together along the ground
- Potential equalization
- Earthing of the workpiece. In cases where it is not possible to earth the workpiece directly, it should be connected by means of suitable capacitors.
- Shielding from other equipment in the surrounding area or the entire welding system

**Electromagnetic fields!**

The power source may cause electrical or electromagnetic fields to be produced which could affect the correct functioning of electronic equipment such as IT or CNC devices, telecommunication lines, power cables, signal lines and pacemakers.



- Observe the maintenance instructions > see 6.3 chapter!
- Unwind welding leads completely!
- Shield devices or equipment sensitive to radiation accordingly!
- The correct functioning of pacemakers may be affected (obtain advice from a doctor if necessary).

CAUTION



Obligations of the operator!

The respective national directives and laws must be complied with when operating the machine!

- Implementation of national legislation relating to framework directive 89/391/EEC on the introduction of measures to encourage improvements in the safety and health of workers at work and associated individual guidelines.
- In particular, directive 89/655/EEC concerning the minimum safety and health requirements for the use of work equipment by workers at work.
- The regulations applicable to occupational safety and accident prevention in the country concerned.
- Setting up and operating the machine as per IEC 60974.-9.
- Brief the user on safety-conscious work practices on a regular basis.
- Regularly inspect the machine as per IEC 60974.-4.



The manufacturer's warranty becomes void if non-genuine parts are used!

- ***Only use system components and options (power sources, welding torches, electrode holders, remote controls, spare parts and replacement parts, etc.) from our range of products!***
- ***Only insert and lock accessory components into the relevant connection socket when the machine is switched off.***

Requirements for connection to the public mains network

High-performance machines can influence the mains quality by taking current from the mains network. For some types of machines, connection restrictions or requirements relating to the maximum possible line impedance or the necessary minimum supply capacity at the interface with the public network (Point of Common Coupling, PCC) can therefore apply. In this respect, attention is also drawn to the machines' technical data. In this case, it is the responsibility of the operator, where necessary in consultation with the mains network operator, to ensure that the machine can be connected.

2.4 Transport and installation

WARNING



Risk of injury due to improper handling of shielding gas cylinders!

Improper handling and insufficient securing of shielding gas cylinders can cause serious injuries!

- Observe the instructions from the gas manufacturer and any relevant regulations concerning the use of compressed air!
- Do not attach any element to the shielding gas cylinder valve!
- Prevent the shielding gas cylinder from heating up.

⚠ CAUTION**Risk of accidents due to supply lines!**

During transport, attached supply lines (mains leads, control cables, etc.) can cause risks, e.g. by causing connected machines to tip over and injure persons!

- Disconnect all supply lines before transport!

**Risk of tipping!**

There is a risk of the machine tipping over and injuring persons or being damaged itself during movement and set up. Tilt resistance is guaranteed up to an angle of 10° (according to IEC 60974-1).

- Set up and transport the machine on level, solid ground.
- Secure add-on parts using suitable equipment.

**Risk of accidents due to incorrectly installed leads!**

Incorrectly installed leads (mains, control and welding leads or intermediate hose packages) can present a tripping hazard.

- Lay the supply lines flat on the floor (avoid loops).
- Avoid laying the leads on passage ways.

**Risk of injury from heated coolant and its connections!**

The coolant used and its connection or connection points can heat up significantly during operation (water-cooled version). When opening the coolant circuit, escaping coolant may cause scalding.

- Open the coolant circuit only when the power source or cooling unit is switched off!
- Wear proper protective equipment (protective gloves)!
- Seal open connections of the hose leads with suitable plugs.



The units are designed for operation in an upright position!

Operation in non-permissible positions can cause equipment damage.

- ***Only transport and operate in an upright position!***



Accessory components and the power source itself can be damaged by incorrect connection!

- ***Only insert and lock accessory components into the relevant connection socket when the machine is switched off.***
- ***Comprehensive descriptions can be found in the operating instructions for the relevant accessory components.***
- ***Accessory components are detected automatically after the power source is switched on.***



Protective dust caps protect the connection sockets and therefore the machine against dirt and damage.

- ***The protective dust cap must be fitted if there is no accessory component being operated on that connection.***
- ***The cap must be replaced if faulty or if lost!***

3 Intended use

WARNING



Hazards due to improper usage!

The machine has been constructed to the state of the art and any regulations and standards applicable for use in industry and trade. It may only be used for the welding procedures indicated at the rating plate. Hazards may arise for persons, animals and material objects if the equipment is not used correctly. No liability is accepted for any damages arising from improper usage!

- The equipment must only be used in line with its designated purpose and by trained or expert personnel!
- Do not improperly modify or convert the equipment!

3.1 Applications

3.1.1 Picomig 225 puls TKG

Arc welding machine for standard and pulsed gas-shielded metal-arc welding with TIG welding and lift arc (touch starting) or MMA welding as secondary process. It may be possible to expand the functionality by using accessories (see the documentation in the relevant chapter).

3.1.2 Picomig 225 Synergic TKG

Arc welding machine for GMAW standard welding and in the secondary process TIG welding with Liftarc (contact ignition) or MMA welding. Accessory components may expand the range of functions (see the relevant documentation in the chapter of the same name).

3.2 Documents which also apply

3.2.1 Warranty

For more information refer to the "Warranty registration" brochure supplied and our information regarding warranty, maintenance and testing at www.ewm-group.com!

3.2.2 Declaration of Conformity



This product corresponds in its design and construction to the EU directives listed in the declaration. The product comes with a relevant declaration of conformity in the original.

The manufacturer recommends carrying out the safety inspection according to national and international standards and guidelines every 12 months.

3.2.3 Welding in environments with increased electrical hazards



Power sources with this marking can be used for welding in an environment with increased electrical hazard (e.g. boilers). For this purpose, appropriate national or international regulations must be followed. The power source must not be placed in the danger zone!

3.2.4 Service documents (spare parts and circuit diagrams)

WARNING



No improper repairs and modifications!

To prevent injuries and damage to the machine, only competent personnel (authorised service personnel) are allowed to repair or modify the machine.

Unauthorised manipulations will invalidate the warranty!

- Instruct competent personnel (authorised service personnel) to repair the machine.

Original copies of the circuit diagrams are enclosed with the unit.

Spare parts can be obtained from the relevant authorised dealer.

3.2.5 Calibration/Validation

An original certificate is enclosed with the product. The manufacturer recommends calibration / validation at intervals of 12 months.

3.2.6 Part of the complete documentation

This document is part of the complete documentation and valid only in combination with all other parts of these instructions! Read and observe the operating instructions for all system components, especially the safety instructions!

The illustration shows a general example of a welding system.

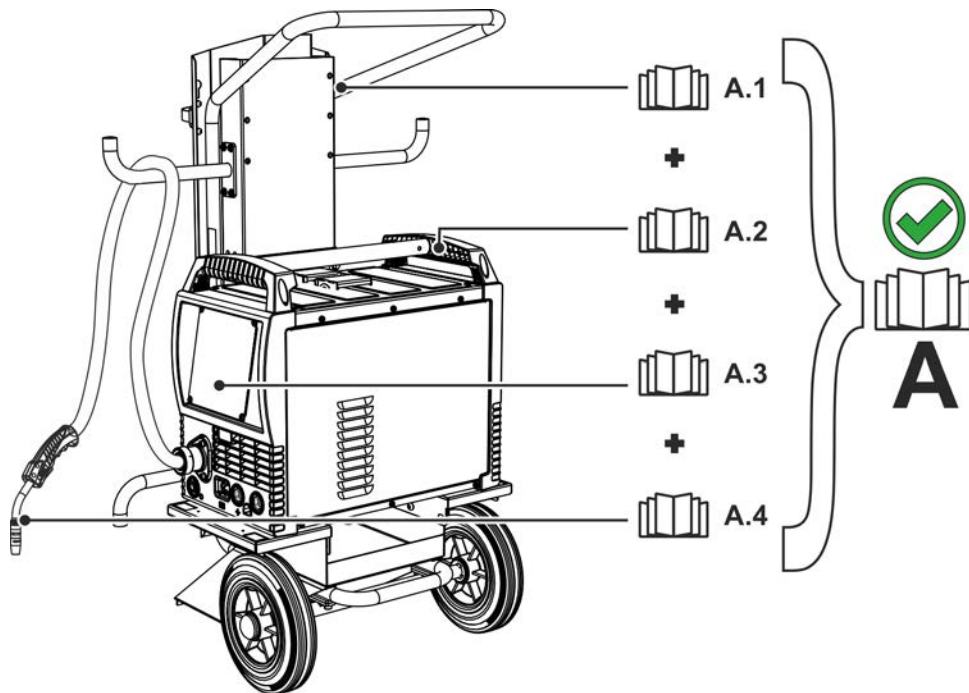

Figure 3-1

Item	Documentation
A.1	Transport cart
A.2	Power source
A.3	Controller
A.4	Welding torch
A	Complete documentation

4 Machine description – quick overview

4.1 Front view / rear view

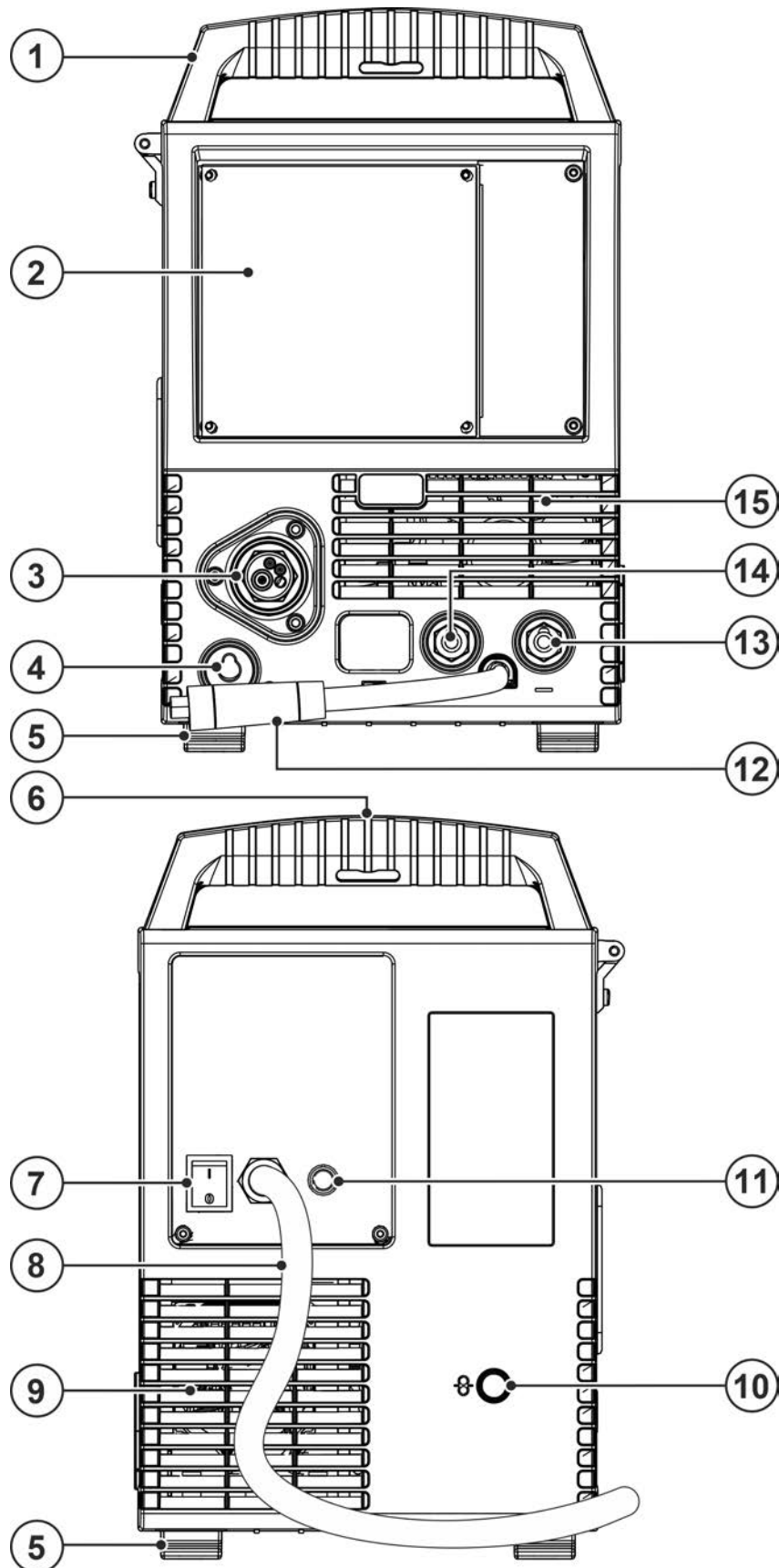







Figure 4-1

Item	Symbol	Description
1		Carrying handle
2		Machine control (see the relevant control operating instructions)
3		Welding torch connection (Euro torch connector) Welding current, shielding gas and torch trigger integrated
4		Park socket, polarity selection plug Retainer for the polarity selection plug in MMA mode or for transport.
5		Machine feet
6		Transport bar
7		Main Switch Switching the machine on or off.
8		Mains connection cable > see 5.1.7 chapter
9		Cooling air outlet
10		External wire feed inlet Pre-cut casing inlet for external wire feed.
11		Connection thread - G$\frac{1}{4}$" Shielding gas connection (inlet)
12		Welding current cable, polarity selection Welding current to Euro torch connector/torch, for polarity selection <ul style="list-style-type: none"> • ----- MIG/MAG: Connection socket for "+" welding current • ----- Self-shielding flux cored wire/TIG: Connection socket, "-" welding current • ----- MMA: Park socket
13		"-" welding current connection socket <ul style="list-style-type: none"> • ----- MIG/MAG welding: Workpiece connection • ----- TIG welding: Welding current connection for welding torch • ----- MMA welding: electrode holder connection
14		Connection socket, "+" welding current <ul style="list-style-type: none"> • ----- MIG/MAG cored wire welding: Workpiece connection • ----- TIG welding: Workpiece connection • ----- MMA welding: Workpiece connection
15		Cooling air inlet

4.2 Inside view

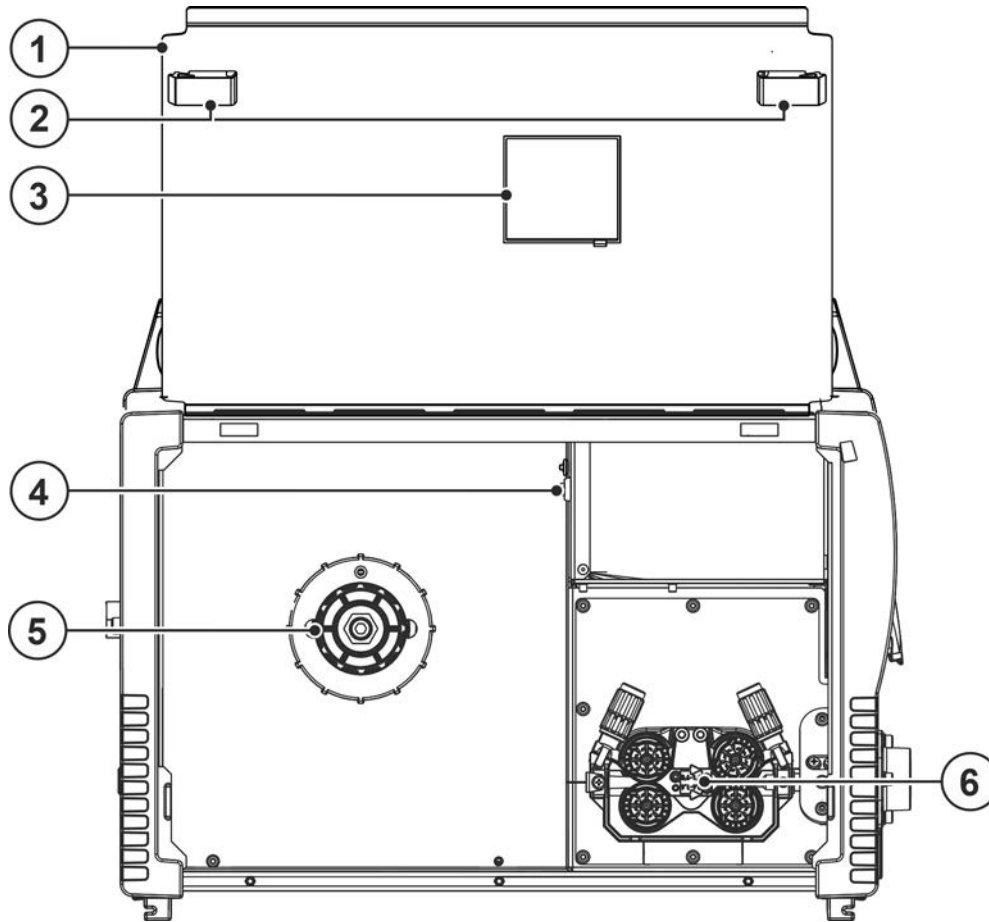

Figure 4-2

Item	Symbol	Description
1		Protective cap Cover for the wire feed mechanism and other operating elements. Depending on the machine series, additional stickers with information on the replacement parts and JOB lists will be located on the inside.
2		Slide latch, lock for the protective cap
3		Wire spool inspection window Check wire supply
4		Push-button, wire inching Potential- and gas-free inching of the wire electrode through the hose package to the welding torch > see 5.2.2.3 chapter.
5		Wire spool holder
6		Wire feed unit > see 5.2.2 chapter

5 Design and function

⚠ WARNING



Risk of injury from electrical voltage!

Contact with live parts, e.g. power connections, can be fatal!

- Observe the safety information on the first pages of the operating instructions!
- Commissioning must be carried out by persons who are specifically trained in handling power sources!
- Connect connection or power cables while the machine is switched off!

⚠ CAUTION



Risk of injury due to moving parts!

The wire feeders are equipped with moving parts, which can trap hands, hair, clothing or tools and thus injure persons!

- Do not reach into rotating or moving parts or drive components!
- Keep casing covers or protective caps closed during operation!



Risk of injury due to welding wire escaping in an unpredictable manner!

Welding wire can be conveyed at very high speeds and, if conveyed incorrectly, may escape in an uncontrolled manner and injure persons!

- Before mains connection, set up the complete wire guide system from the wire spool to the welding torch!
- Check wire guide at regular intervals!
- Keep all casing covers or protective caps closed during operation!

Read and observe the documentation to all system and accessory components!

5.1 Transport and installation

⚠ WARNING



Risk of accident due to improper transport of machines that must not be lifted!

Do not lift or suspend the machine! The machine can drop and cause injuries! The handles, straps or brackets are suitable for transport by hand only!

- The machine must not be suspended or lifted using a crane.
- Depending on machine type, equipment for lifting by crane or use while suspended is available as a retrofitting option > see 9 chapter.

Damage to the machine due to improper transport!

The machine can be damaged by tensile or lateral forces if it is set down or picked up in a non-vertical position!

- Do not drag the machine horizontally on the machine feet!
- Always pick up the machine vertically and set it down carefully.

5.1.1 Ambient conditions



The machine must not be operated in the open air and must only be set up and operated on a suitable, stable and level base!

- The operator must ensure that the ground is non-slip and level, and provide sufficient lighting for the place of work.
- Safe operation of the machine must be guaranteed at all times.



Equipment damage due to contamination!

Unusually high amounts of dust, acids, corrosive gases or substances can damage the machine (observe maintenance intervals > see 6.3 chapter).

- Avoid large amounts of smoke, steam, oily fumes, grinding dust and corrosive ambient air!

In operation

Temperature range of the ambient air:

- -25 °C to +40 °C (-13 °F to 104 °F) ^[1]

Relative humidity:

- up to 50 % at 40 °C (104 °F)
- up to 90 % at 20 °C (68 °F)

Transport and storage

Storage in a closed room, temperature range of the ambient air:

- -30 °C to +70 °C (-22 °F to 158 °F) ^[1]

Relative humidity

- up to 90 % at 20 °C (68 °F)

^[1] Ambient temperature dependent on coolant! Observe the coolant temperature range of the torch cooling

5.1.2 Machine cooling



Insufficient ventilation results in a reduction in performance and equipment damage.

- **Observe the ambient conditions!**
- **Keep the cooling air inlet and outlet clear!**
- **Observe the minimum distance of 0.5 m from obstacles!**

5.1.3 Workpiece lead, general

CAUTION



Risk of burning due to incorrect welding current connection!

If the welding current plugs (machine connections) are not locked or if the workpiece connection is contaminated (paint, corrosion), these connections and leads can heat up and cause burns when touched!

- Check welding current connections on a daily basis and lock by turning to the right when necessary.
- Clean workpiece connection thoroughly and secure properly. Do not use structural parts of the workpiece as welding current return lead!

5.1.4 Notes on the installation of welding current leads

- Incorrectly installed welding current leads can cause faults in the arc (flickering).
- Lay the workpiece lead and hose package of power sources without HF igniter (MIG/MAG) for as long and as close as possible in parallel.
- Lay the workpiece lead and hose package of power sources with HF igniter (TIG) for as long as possible in parallel with a distance of 20 cm to avoid HF sparkover.
- Always keep a distance of at least 20 cm to leads of other power sources to avoid interferences
- Always keep leads as short as possible! For optimum welding results max. 30 m (welding lead + intermediate hose package + torch lead).

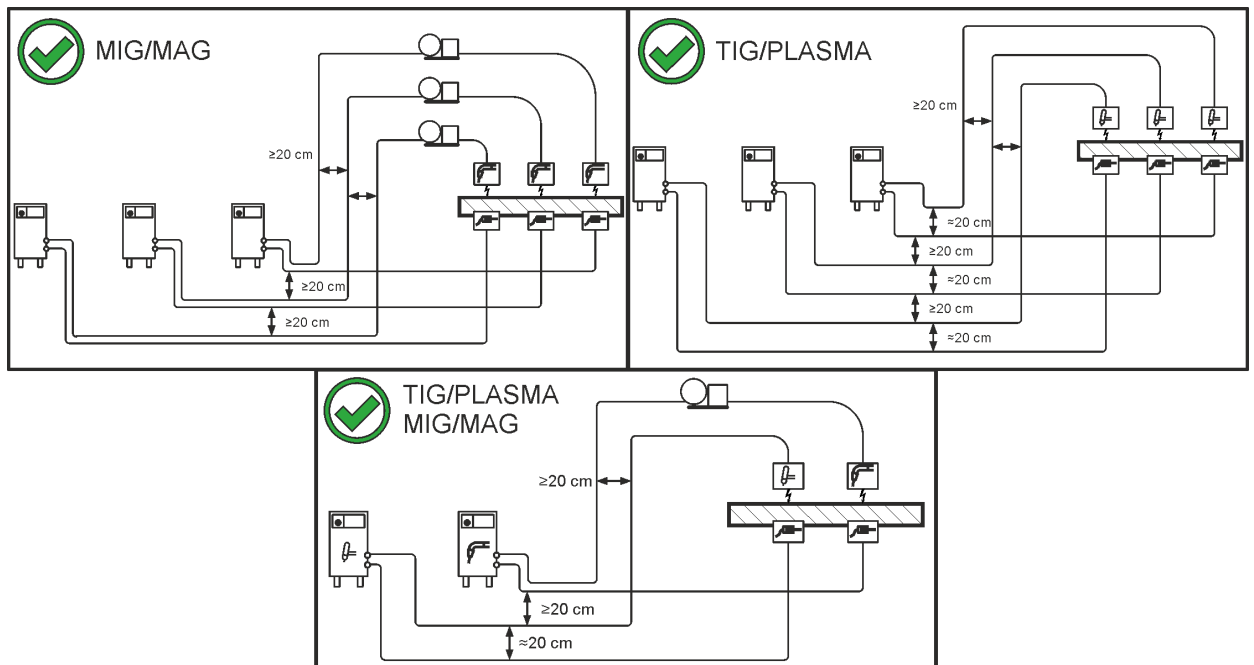

Figure 5-1

- Use an individual welding lead to the workpiece for each welding machine!

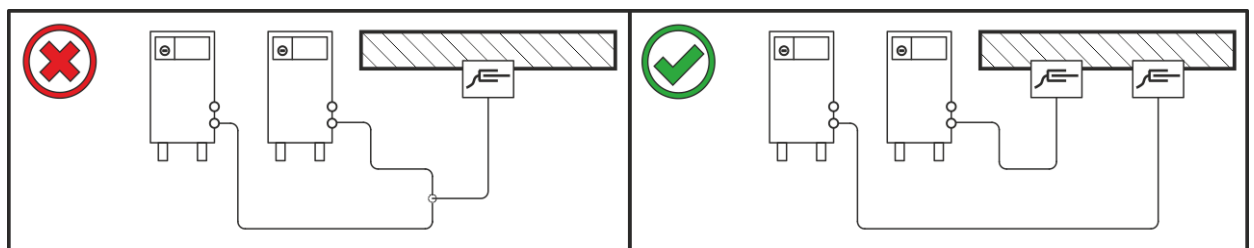

Figure 5-2

- Fully unroll welding current leads, torch hose packages and intermediate hose packages. Avoid loops!
- Always keep leads as short as possible!

Lay any excess cable lengths in meanders.

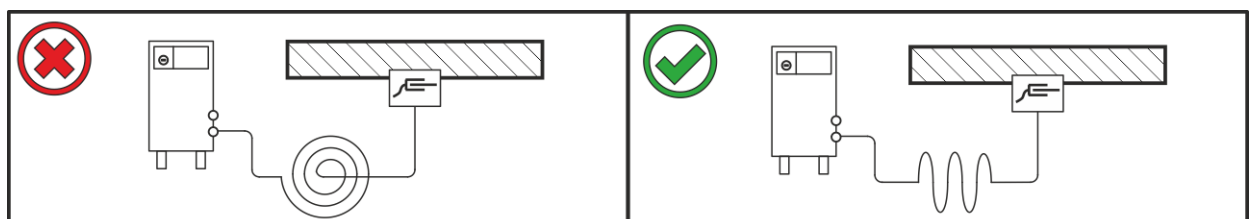

Figure 5-3

5.1.5 Stray welding currents

⚠ WARNING



Risk of injury due to stray welding currents!

Stray welding currents can destroy protective earth conductors, damage machines and electronic devices and cause overheating of components, leading to fire.

- Check that all welding current connections are firmly secured and electrical connections are in perfect condition.
- Set up, attach or suspend all conductive power source components such as casing, transport vehicles and crane frames so they are insulated.
- Do not place any other electronic devices such as drills or angle grinders on the power source, transport vehicle or crane frames unless they are insulated.
- Always put welding torches and electrode holders on an insulated surface when they are not in use.

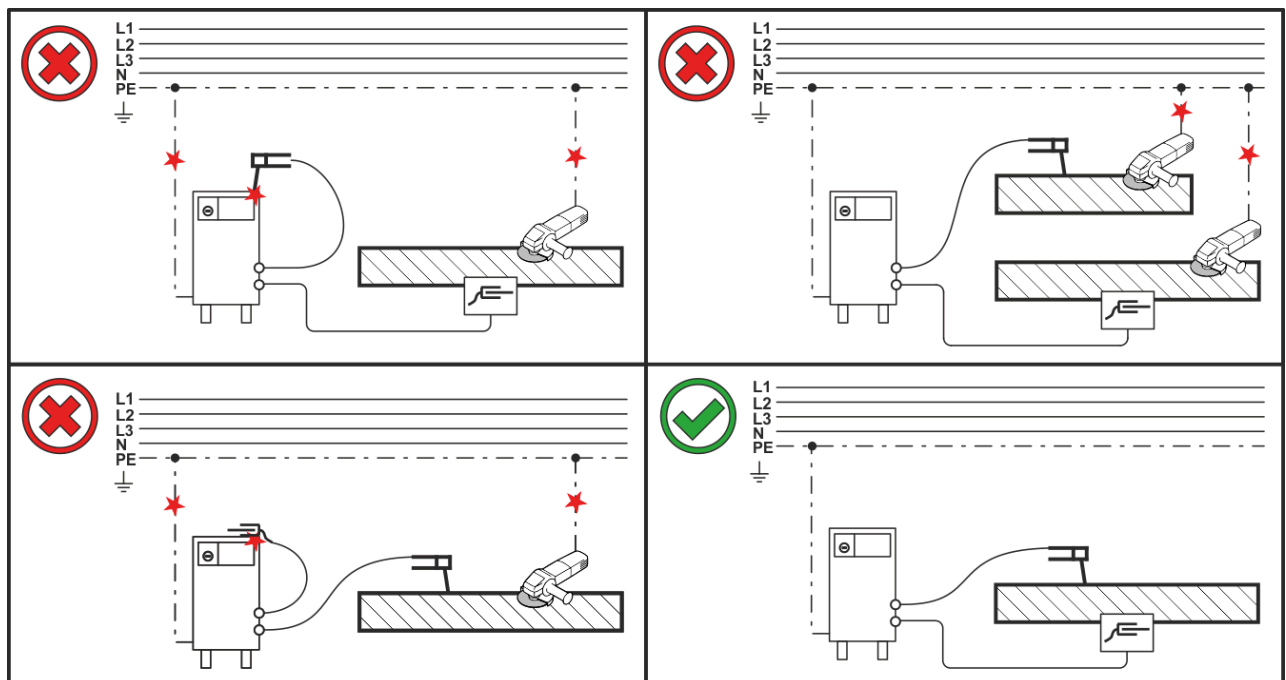

Figure 5-4

5.1.6 Welding torch holder

The item described in the following is part of the machine's scope of delivery.

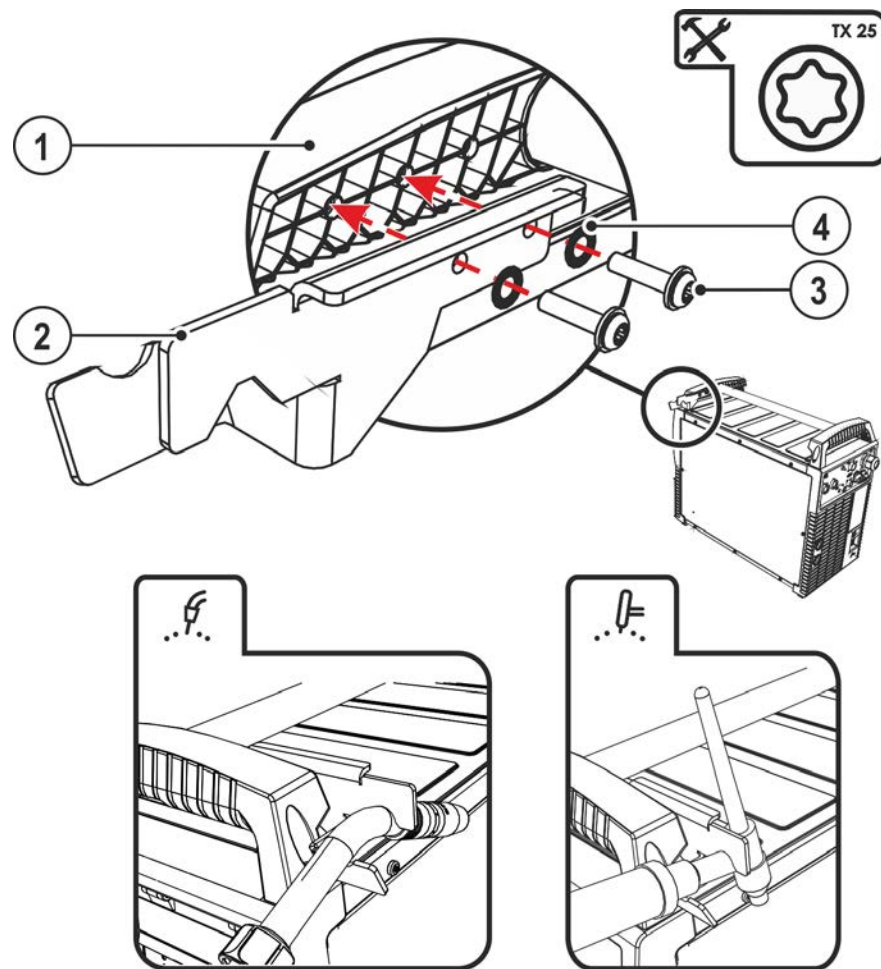

Figure 5-5

Item	Symbol	Description
1		Crossmember of the transport handle
2		Torch holder
3		Fixing screws (x 4)
4		Fan-type lock washers

- Use the mounting screws to screw the torch holder onto the crossmember of the transport handle.
- Insert the welding torch into the welding torch holder as shown.

5.1.7 Mains connection

DANGER



Hazards caused by improper mains connection!

An improper mains connection can cause injuries or damage property!

- The connection (mains plug or cable), the repair or voltage adjustment of the device must be carried out by a qualified electrician in accordance with the respective local laws or national regulations!
- The mains voltage indicated on the rating plate must match the supply voltage.
- Only operate machine using a socket that has correctly fitted protective earth.
- Mains plug, socket and lead must be checked by a qualified electrician on a regular basis!
- When operating the generator, always ensure it is earthed as stipulated in the operating instructions. The network created must be suitable for operating machines according to protection class I.

5.1.7.1 Mains configuration



The machine may only be connected to a one-phase system with two conductors and an earthed neutral conductor.

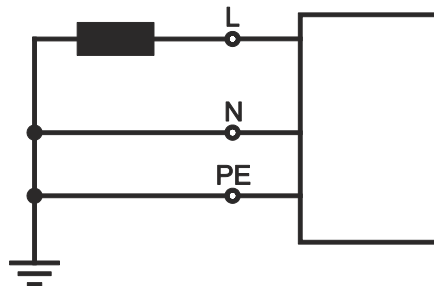

Figure 5-6

Legend

Item	Designation	Colour code
L	Outer conductor	brown
N	Neutral conductor	blue
PE	Protective conductor	green-yellow

- Insert mains plug of the switched-off machine into the appropriate socket.

5.1.8 Shielding gas supply (shielding gas cylinder for welding machine)

⚠ WARNING



Risk of injury due to improper handling of shielding gas cylinders! Improper handling and insufficient securing of shielding gas cylinders can cause serious injuries!

- Place shielding gas cylinder into the designated holder and secure with fastening elements (chain/belt)!
- Attach the fastening elements within the upper half of the shielding gas cylinder!
- The fastening elements must tightly enclose the shielding gas cylinder!

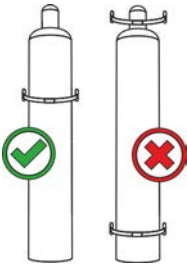

👉 An unhindered shielding gas supply from the shielding gas cylinder to the welding torch is a fundamental requirement for optimum welding results. In addition, a blocked shielding gas supply may result in the welding torch being destroyed.

- **Always re-fit the yellow protective cap when not using the shielding gas connection.**
- **All shielding gas connections must be gas tight.**

5.1.8.1 Pressure regulator connection

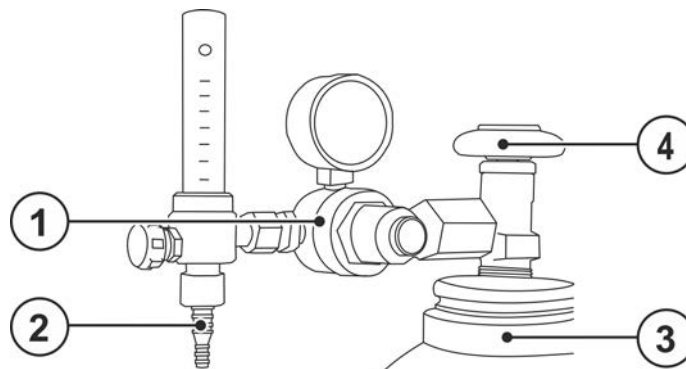

Figure 5-7

Item	Symbol	Description
1		Pressure regulator
2		Output side of the pressure regulator
3		Shielding gas cylinder
4		Cylinder valve

- Before connecting the pressure regulator to the gas cylinder, open the cylinder valve briefly to blow out any dirt.
- Tighten the pressure regulator screw connection on the gas bottle valve to be gas-tight.
- Screw the gas hose connection to the outlet side of the pressure regulator gas-tight.

5.1.8.2 Shielding gas hose connection

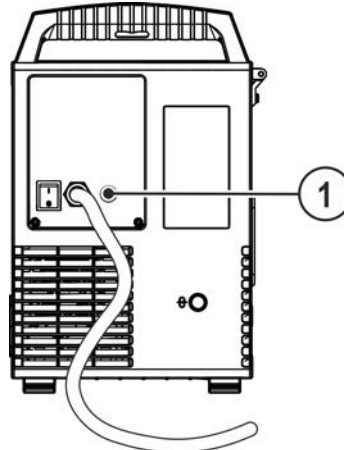

Figure 5-8

Item	Symbol	Description
1		Connection thread - G$\frac{1}{4}$" Shielding gas connection (inlet)

- Screw the gas hose connection to the shielding gas connection (inlet) on the machine gas-tight.

5.1.8.3 Gas test – setting the shielding gas volume

If the shielding gas setting is too low or too high, this can introduce air to the weld pool and may cause pores to form. Adjust the shielding gas quantity to suit the welding task!

- Slowly open the gas cylinder valve.
- Open the pressure regulator.
- Switch on the power source at the main switch.
- Set the relevant gas quantity for the application on the pressure regulator.
- You can activate the gas test by briefly pressing the “Gas test \square ” push-button on the machine control (welding voltage and wire feed motor remain switched off – no unintentional ignition of the arc).

Shielding gas flows for around 25 seconds or until the button is pressed again.

Repeat rinsing process several times.

Setting instructions

Welding process	Recommended shielding gas quantity
MAG welding	Wire diameter x 11.5 = l/min
MIG brazing	Wire diameter x 11.5 = l/min
MIG welding (aluminium)	Wire diameter x 13.5 = l/min (100 % argon)
TIG	Gas nozzle diameter in mm corresponds to l/min gas throughput

Helium-rich gas mixtures require a higher gas volume!

The table below can be used to correct the gas volume calculated where necessary:

Shielding gas	Factor
75% Ar/25% He	1.14
50% Ar/50% He	1.35
25% Ar/75% He	1.75
100% He	3.16

5.1.9 Dirt filter

These accessory components can be retrofitted as an option > see 9 chapter.

When using a dirt filter, the cooling air throughput is reduced and the duty cycle of the machine is reduced as a result. The duty cycle decreases with the increasing contamination of the filter. The dirt filter must be removed at regular intervals and cleaned by blowing out with compressed air (depending on the level of soiling).

5.2 MIG/MAG welding

5.2.1 Welding torch and workpiece line connection

On delivery, the Euro torch connector is fitted with a capillary tube for welding torches with a steel liner. Conversion is necessary if a welding torch with a liner is used!

- Operate welding torches with a liner > with a guide tube.
- Operate welding torches with a steel liner > with a capillary tube.

For connection, observe the operating instructions for the welding torch.

Depending on the wire electrode diameter or type, either a steel liner or liner with the correct inner diameter must be inserted in the torch!

Recommendation:

- Use a steel liner when welding hard, unalloyed wire electrodes (steel).
- Use a chrome nickel liner when welding hard, high-alloy wire electrodes (CrNi).
- Use a plastic or teflon liner when welding or brazing soft wire electrodes, high-alloy wire electrodes or aluminium materials.

Preparation for connecting welding torches with a spiral guide:

- Check that the capillary tube is correctly positioned in relation to the central connector!

Preparation for connecting welding torches with a liner:

- Push forward the capillary tube on the wire feed side in the direction of the Euro torch connector and remove it there.
- Insert the liner guide tube from the Euro torch connector side.
- Carefully insert the welding torch connector with as yet too long a liner into the Euro torch connector and secure with a crown nut.
- Cut off the liner with a liner cutter > see 9 chapter just before the wire feed roller.
- Loosen the welding torch connector and remove.
- Carefully chamfer the cut off end of the liner with a liner sharpener > see 9 chapter and sharpen.

Choose welding current connection socket according to the signal light for the polarity setting!

- Select JOB > see 5.2.3 chapter
- Polarity selection “+” or polarity selection “-” signal lights show the polarity setting.

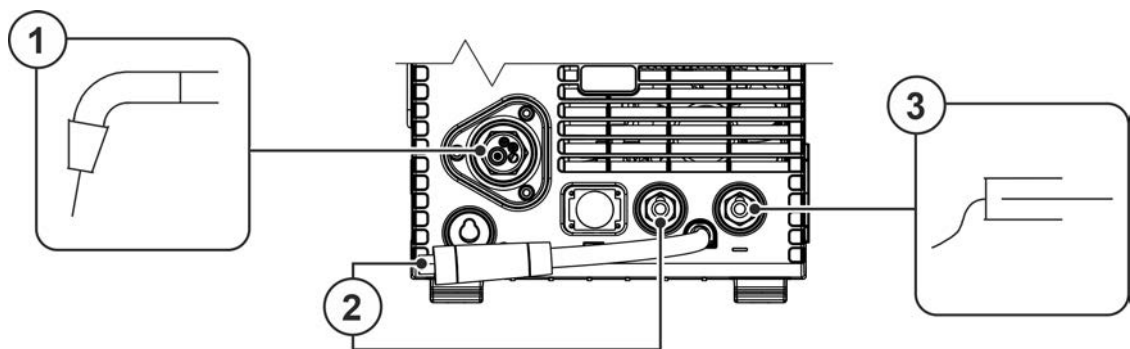

Figure 5-9

Item	Symbol	Description
1		Welding torch
2		Polarity selector plug, welding current cable Internal welding current cable for central connection/welding torch. • ----- Connection socket for “+” welding current
3		Workpiece

- Insert the central plug for the welding torch into the central connector and screw together with crown nut.
- Insert the plug of the workpiece lead in the respective welding current connection socket and lock in place by turning to the right.
- Insert the polarity selection plug in the respective welding current connection socket and lock in place by turning to the right.

Some wire electrodes (for example self-shielded flux cored wire) must be welded with negative polarity (follow the electrode manufacturer's instructions). In this case, the polarity selection plug must be plugged into the “-” welding current socket and the workpiece lead into the “+” welding current socket and locked.

5.2.2 Wire feed

⚠ CAUTION



Risk of injury due to moving parts!

The wire feeders are equipped with moving parts, which can trap hands, hair, clothing or tools and thus injure persons!

- Do not reach into rotating or moving parts or drive components!
- Keep casing covers or protective caps closed during operation!



Risk of injury due to welding wire escaping in an unpredictable manner!

Welding wire can be conveyed at very high speeds and, if conveyed incorrectly, may escape in an uncontrolled manner and injure persons!

- Before mains connection, set up the complete wire guide system from the wire spool to the welding torch!
- Check wire guide at regular intervals!
- Keep all casing covers or protective caps closed during operation!

5.2.2.1 Inserting the wire spool

⚠ CAUTION



Risk of injury due to incorrectly secured wire spool.

If the wire spool is not secured properly, it may come loose from the wire spool support and fall to the ground, causing damage to the machine and injuries.

- Make sure to correctly fasten the wire spool to the wire spool support.
- Before you start working, always check the wire spool is securely fastened.

Standard D300 wire spool holder can be used. Adapters are required when using standardised basket coils (DIN 8559) > see 9 chapter.

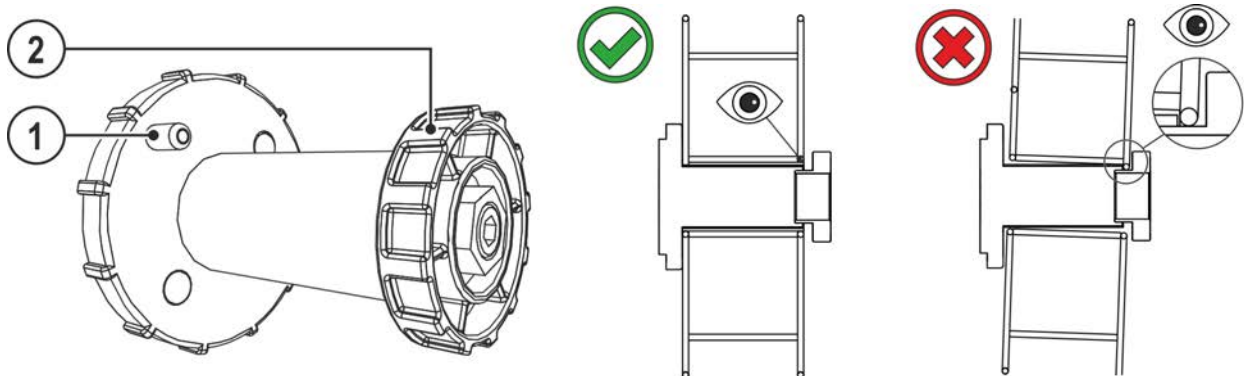

Figure 5-10

Item	Symbol	Description
1		Carrier pin For fixing the wire spool
2		Knurled nut For fixing the wire spool

- Unlock and open protective flap.
- Loosen knurled nut from spool holder.
- Fix welding wire reel onto the spool holder so that the carrier pin locks into the spool bore.
- Fasten wire spool using knurled nut.

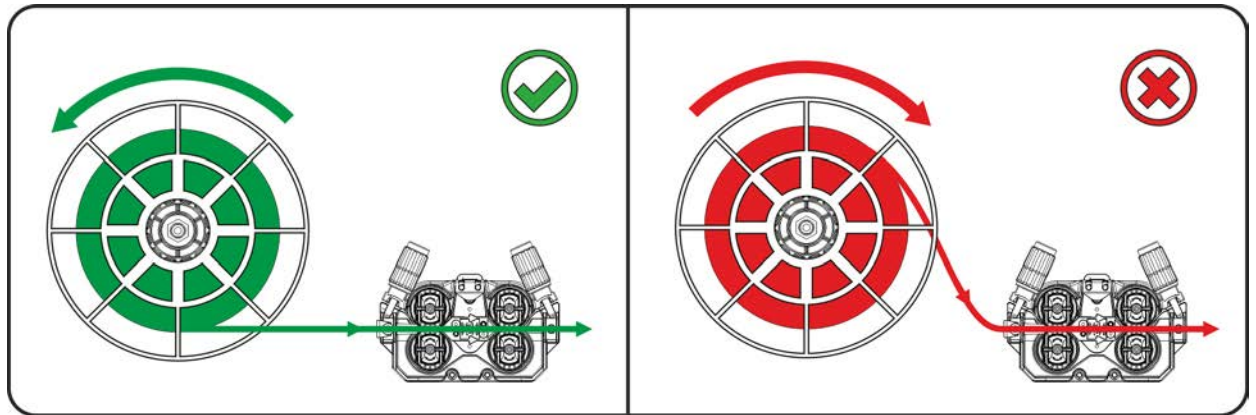

Figure 5-11

Observe the unwinding direction of the wire spool.

5.2.2.2 Changing the wire feed rollers

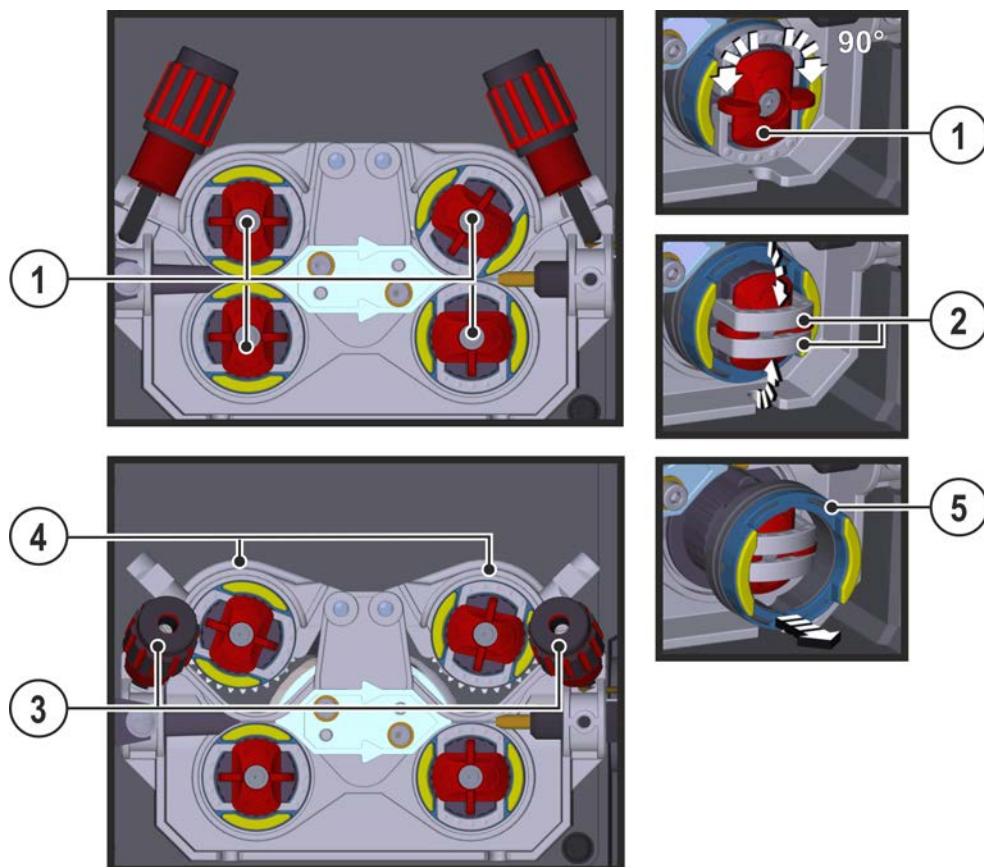

Figure 5-12

Item	Symbol	Description
1		Tommy The tommy is used to secure the closure brackets of the wire feed rollers.
2		Closure bracket The closure brackets are used to secure the wire feed rollers.
3		Feed roll tensioner Fixing the clamping unit and setting the pressure.

Item	Symbol	Description
4		Clamping unit
5		Wire feed roller see the Wire feed roller overview table

- Rotate the tommy by 90° clockwise or anti-clockwise (tommy locks into place).
- Fold the closure brackets outwards by 90°.
- Unfasten pressure units and fold out (clamping units and pressure rollers will automatically flip upwards).
- Remove the wire feed rollers from the roller support.
- Select new wire feed rollers according to the Wire feed roller overview table and reassemble the wire feed mechanism in reverse order.

Unsatisfactory welding results due to faulty wire feeding!

The wire feed rolls must be suitable for the diameter of the wire and the material. The wire feed rolls are colour-coded to facilitate distinction (see the Wire feed roll overview table). When working with a wire diameter of > 1.6 mm the drive has to be converted for the wire feed kit ON WF 2,0-3,2MM EFEED > see 10 chapter.

Wire feed roll overview table:

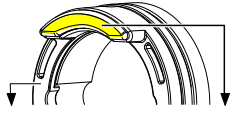
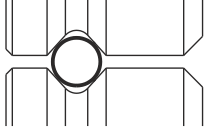
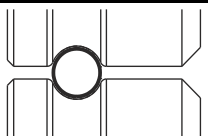
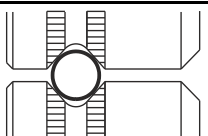
Material	Diameter		Colour code			Groove form
	Ø mm	Ø inch				
Steel Stainless steel Brazing	0.6	.024	monochrome	light pink	-	 V-groove
	0.8	.031		white		
	0.8	.031	bicolour	white	blue	
	0.9	.035				
	1.0	.039				
	1.0	.039		blue	red	
	1.2	.047				
	1.4	.055	monochrome	green	-	
	1.6	.063		black		
	2.0	.079		grey		
2.4	.094	brown				
2.8	.110	light green				
3.2	.126	purple				
Aluminium	0.8	.031	bicolour	white	yellow	 U-groove
	0.9	.035		blue		
	1.0	.039				
	1.2	.047		red		
	1.6	.063		black		
	2.0	.079		grey		
	2.4	.094		brown		
	2.8	.110		light green		
	3.2	.126		purple		
Flux cored wire	0.8	.031	bicolour	white	orange	 V-groove, knurled
	0.9	.035		blue		
	1.0	.039				
	1.2	.047		red		
	1.4	.055		green		
	1.6	.063		black		
	2.0	.079		grey		
	2.4	.094		brown		

5.2.2.3 Inching the wire electrode

⚠ CAUTION



Risk of injury due to welding wire escaping from the welding torch!
The welding wire can escape from the welding torch at high speed and cause bodily injury including injuries to the face and eyes!

- Never direct the welding torch towards your own body or towards other persons!



Improper contact pressure increases wear on the wire feed rolls.

Adjust the contact pressure on the adjusting nuts of the feed roll tensioners so that the wire electrode is fed but slips when the wire spool is blocked.

The inching speed is infinitely adjustable by simultaneously pressing the wire inching push-button and turning the wire speed rotary knob.

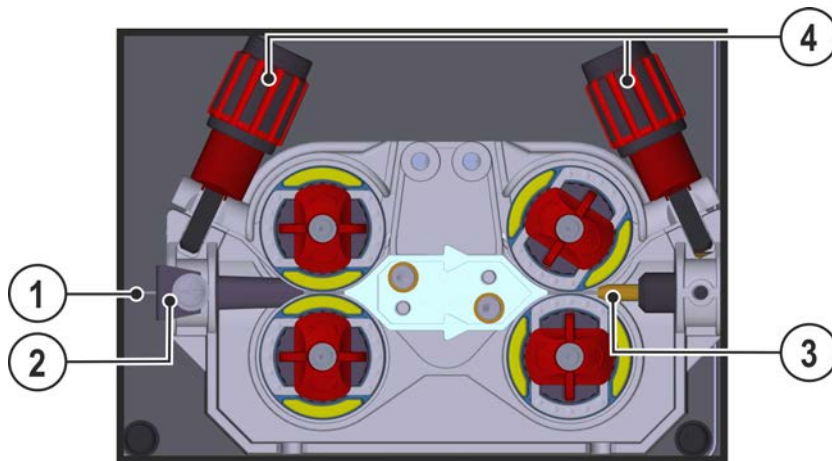

Figure 5-13

Item	Symbol	Description
1		Welding wire
2		Wire feed nipple
3		Guide tube
4		Adjusting nut

- Extend and lay out the torch hose package.
- Carefully unwind the welding wire from the wire spool and insert through the wire feed nipples up to the wire feed rollers.
- Press the inching push-button (the drive catches the welding wire and automatically guides it to the welding torch outlet) > see 4.2 chapter.

- The contact pressure has to be adjusted separately for each side (wire inlet/outlet) at the feed roll tensioner setting nuts depending on the welding consumable used. A table with the setting values can be found on a sticker near the wire drive.

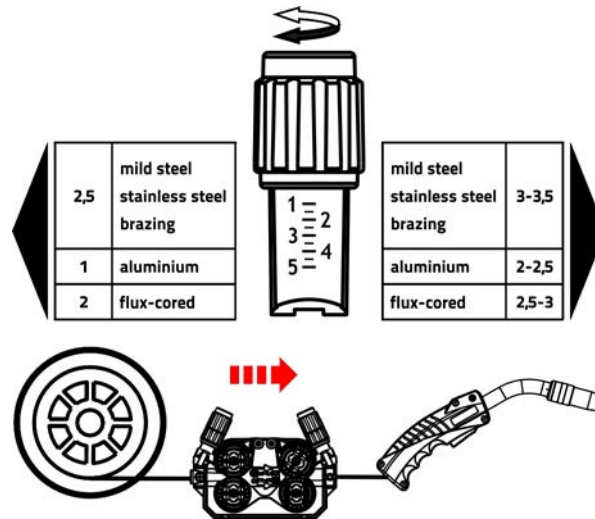

Figure 5-14

5.2.2.4 Spool brake setting

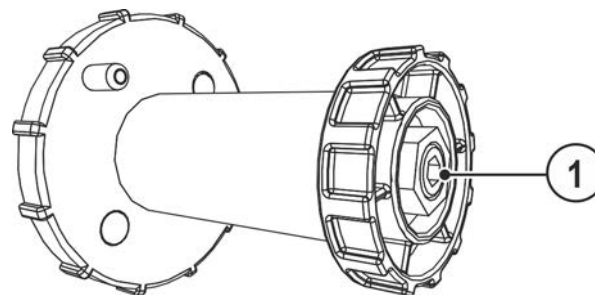

Figure 5-15

Item	Symbol	Description
1		Allen screw Securing the wire spool retainer and adjustment of the spool brake

- Tighten the Allen screw (8 mm) in the clockwise direction to increase the braking effect.
Tighten the spool brake until the wire spool no longer turns when the wire feed motor stops but without it jamming during operation!

5.2.3 Welding task selection

For selection of the welding task and for general operation see the relevant Control operating instructions.

5.3 MMA welding

5.3.1 Connecting the electrode holder and workpiece lead

⚠ CAUTION



Risk of crushing and burns!

When changing stick electrodes there is a risk of crushing and burns!

- Wear appropriate and dry protective gloves.
- Use an insulated pair of tongs to remove the used stick electrode or to move welded workpieces.

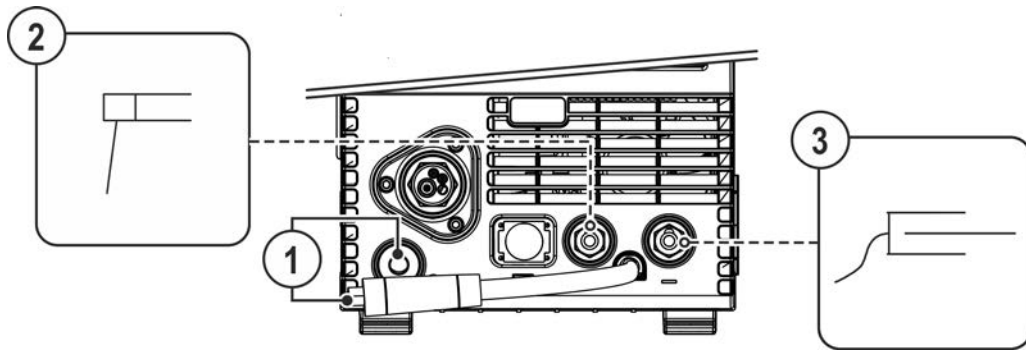

Figure 5-16

Item	Symbol	Description
1		Polarity selector plug, welding current cable • Connect to the park socket.
2		Electrode holder
3		Workpiece

- Insert the polarity selection plug in the park socket and lock in place by turning to the right.
- Insert the electrode holder plug and workpiece lead into the welding current socket depending on application and lock in place by turning to the right. The corresponding polarity will be based on the information of the electrode manufacturer on the electrode packaging.

5.3.2 Welding task selection

For selection of the welding task and for general operation see the relevant Control operating instructions.

5.4 TIG welding

5.4.1 Preparing the TIG welding torch

The TIG welding torch is to be equipped to suit the relevant welding task!

- Fit suitable tungsten electrodes and
- an appropriate shielding gas nozzle.
- Observe the operating instructions for the TIG welding torch!

5.4.2 Welding torch and workpiece line connection

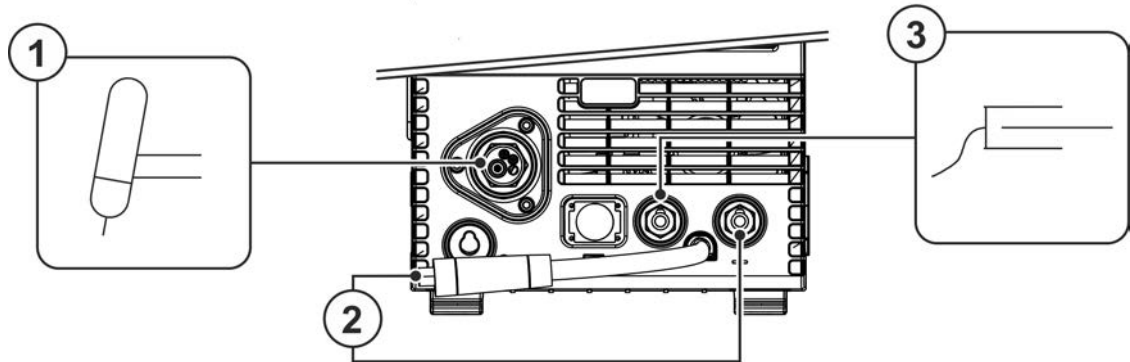

Figure 5-17

Item	Symbol	Description
1		Welding torch
2		Polarity selector plug, welding current cable Internal welding current cable for central connection/welding torch. • Connection socket for "-" welding current
3		Workpiece

- Insert the central plug for the welding torch into the central connector and screw together with crown nut.
- Insert the polarity selection plug into the "-" welding current connection socket and lock in place by turning to the right.
- Insert the plug of the workpiece lead into the "+" welding current connection socket and lock in place by turning to the right.

5.4.3 Welding task selection

For selection of the welding task and for general operation see the relevant Control operating instructions.

6 Maintenance, care and disposal

6.1 General

DANGER



Risk of injury due to electrical voltage after switching off!

Working on an open machine can lead to fatal injuries!

Capacitors are loaded with electrical voltage during operation. Voltage remains present for up to four minutes after the mains plug is removed.

1. Switch off machine.
2. Remove the mains plug.
3. Wait for at least 4 minutes until the capacitors have discharged!

WARNING



Improper maintenance, testing and repairs!

Maintenance, testing and repair of the machine may only be carried out by skilled and qualified personnel (authorised service personnel). A competent person is someone who, based on training, knowledge and experience, can recognize the hazards and possible consequential damage that may occur when testing power sources and can take the necessary safety precautions.

- Follow the maintenance instructions > see 6.3 chapter.
- If any of the test requirements below are not met, the unit must not be put back into operation until it has been repaired and tested again.

Repair and maintenance work may only be performed by qualified authorised personnel; otherwise the right to claim under warranty is void. In all service matters, always consult the dealer who supplied the machine. Return deliveries of defective equipment subject to warranty may only be made through your dealer. When replacing parts, use only original spare parts. When ordering spare parts, please quote the machine type, serial number and item number of the machine, as well as the type designation and item number of the spare part.

Under the specified ambient conditions and normal working conditions this machine is essentially maintenance-free and requires just a minimum of care.

Contamination of the machine may impair service life and duty cycle. The cleaning intervals depend on the ambient conditions and the resulting contamination of the machine. The minimum interval is every six months.

6.2 Explanation of icons

Personnel	
	Welder / operator
	Qualified person (authorised service personnel)
Tests	
	Visual inspection
	Functional test
Period, interval	
	One-shift operation
	Multi-shift operation
	Every 8 hours
	Daily
	Weekly
	Monthly
	Every 6 months
	Annually

6.3 Maintenance schedule

Inspector	Type of inspection	8h	24h	Maintenance step	Repairer
				<p>! Only personnel designated as inspectors or repairers due to their training are allowed to carry out the relevant work step! Non-applicable inspection points are omitted.</p> <ul style="list-style-type: none"> Check and clean the welding torch. Deposits in the welding torch may cause short circuits, impair the welding result and lead to welding torch damage! Check wire drive, welding torches, and liner elements for application-related equipment and setting. Clean the wire feed rolls on a regular basis (depending on the degree of soiling). Replace worn wire feed rolls. Connections of the welding current leads (check for tight and locked seating). Is shielding gas cylinder with gas cylinder securing elements (chain/belt) secured? Strain relief: Are hose packages secured with strain relief? 	
				<ul style="list-style-type: none"> Checking all supply lines and their connections (pipes, hoses, hose packages) for damage or leaks. Checking the welding system for damage to the housing. 	

Inspector	Type of inspection			Maintenance step	Repairer
				<p>! Only personnel designated as inspectors or repairers due to their training are allowed to carry out the relevant work step! Non-applicable inspection points are omitted.</p>	
				<ul style="list-style-type: none"> Transport elements (strap, lifting eyes, handle, wheels, parking brake) corresponding safety elements (if necessary fuse caps) are present and flawless? 	
				<ul style="list-style-type: none"> Cleaning connections of coolant pipes (quick connect coupling, connections) from impurities and install protective caps when not in use. Gas test that the solenoid valve opens and closes properly. Checking operating, signalling and indicator lights, protective devices and actuators. 	
				<ul style="list-style-type: none"> Check wire feed roll holder (wire feed rolls must be firmly seated on their holders and must not have any play) Cleaning dirt filter (if applicable) 	
				<ul style="list-style-type: none"> Checking correct mounting of the wire spool. 	
				<ul style="list-style-type: none"> Clean external surfaces with a damp cloth (do not use aggressive cleaning agents). 	
				<ul style="list-style-type: none"> Cleaning the power source (inverter) 	
				<ul style="list-style-type: none"> Cleaning heat exchanger (torch cooling) 	
				<ul style="list-style-type: none"> Coolant change (torch cooling) 	
				<ul style="list-style-type: none"> Periodic inspection and testing 	
				<ul style="list-style-type: none"> The coolant must be checked using the appropriate frost protection tester TYP 1 (KF) or FSP (blueCool) for sufficient frost protection and replaced if necessary (accessories). 	

6.4 Disposing of equipment



Proper disposal!

The machine contains valuable raw materials, which should be recycled, and electronic components, which must be disposed of.

- **Do not dispose of in household waste!**
- **Observe the local regulations regarding disposal!**
- According to European provisions (Directive 2012/19/EU on Waste of Electrical and Electronic Equipment), used electric and electronic equipment may no longer be placed in unsorted municipal waste. It must be collected separately. The symbol depicting a waste container on wheels indicates that the equipment must be collected separately.
This machine has to be disposed of, or recycled, in accordance with the waste separation systems in use.

According to German law (law governing the distribution, taking back and environmentally correct disposal of electrical and electronic equipment (ElektroG)), used machines are to be placed in a collection system separate from unsorted municipal waste. The public waste management utilities (communities) have created collection points at which used equipment from private households can be disposed of free of charge.

The deletion of personal data is the responsibility of the end user.

Lamps, batteries or accumulators must be removed and disposed of separately before disposing of the device. The type of battery or accumulator and its composition is marked on the top (type CR2032 or SR44). The following EWM products may contain batteries or accumulators:

- **Welding helmets**
Batteries or accumulators are easy to remove from the LED cassette.
- **Device controls**
Batteries or accumulators are located on the back of these in corresponding sockets on the circuit board and are easy to remove. The controls can be removed using standard tools.

Information on returning used equipment or collections can be obtained from the respective municipal administration office. Devices can also be returned to EWM sales partners across Europe.

Further information on the topic of the disposal of electrical and electronic equipment can be found on our website at: <https://www.ewm-group.com/de/nachhaltigkeit.html>.

7 Rectifying faults

All products are subject to rigorous production checks and final checks. If, despite this, something fails to work at any time, please check the product using the following flowchart. If none of the fault rectification procedures described leads to the correct functioning of the product, please inform your authorised dealer.

7.1 Software version of the machine control

The query of the software versions only serves to inform the authorised service staff. It is available in the machine configuration menu.

7.2 Error messages (power source)

Depending on the options of the machine display, a fault is shown as follows:

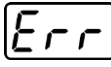
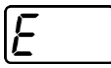
Display type - machine control	Display
Graphic display	
two 7-segment displays	
one 7-segment display	

The possible cause of the fault is signalled by a corresponding fault number (see table). In the case of an error, the power unit shuts down.

The possible error numbers displayed depend on the machine series and version!

- Document machine errors and inform service staff as necessary.
- If multiple errors occur, these are displayed in succession.

Error message	Possible cause	Remedy
E 0	Start signal set in the event of errors	Do not press the torch trigger or the foot-operated remote control
E 4	Temperature error	Allow the machine to cool down
E 5	Mains overvoltage	Switch off the machine and check the mains voltage
E 6	Mains undervoltage	
E 7	Electronics error	Switch the machine off and on again. If the error persists, notify service department
E 9	Secondary overvoltage	
E 12	Voltage reduction error (VRD)	
E 13	Electronics error	Switch off the machine, place the electrode holder in an insulated position and switch the machine back on. If the error persists, notify service department
E 14	Alignment error in current recording	
E 15	Error in one of the electronics supply voltages	Switch the machine off and on again. If the error persists, notify service department
E 23	Temperature error	Allow the machine to cool down
E 32	Electronics error	Switch the machine off and on again. If the error persists, notify service department
E 33	Alignment error in voltage recording	Switch off the machine, place the electrode holder in an insulated position and switch the machine back on. If the error persists, notify service department

Error message	Possible cause	Remedy
E34	Electronics error	Switch the machine off and on again. If the error persists, notify service department
E37	Temperature error	Allow the machine to cool down
E40	Motor fault	Check wire feed mechanism, switch the machine off and on again, inform the service department if the fault persists.
E51	Earth fault (PE error)	Connection between welding wire and machine casing
E55	Failure of a mains phase	Switch off the machine and check the mains vol- tage
E58	Short circuit in welding circuit	Switch off the machine and check welding current leads for correct installation, e.g. by placing the electrode holder in an insulated position; detach current lead from degaussing.

7.3 Checklist for rectifying faults

The correct machine equipment for the material and process gas in use is a fundamental requirement for perfect operation!

Legend	Symbol	Description
	↗	Fault/Cause
	✘	Remedy

Collective interference signal light illuminates

- ↗ Excess temperature, welding machine
 - ✘ Allow the machine to cool down whilst still switched on
- ↗ Welding current monitoring device triggered (stray welding currents flowing across the protective e-arth). The error must be reset by switching the machine off and on again.
 - ✘ Welding wire is touching electrically conductive casing parts (check wire guide, has the welding wire sprung off the wire spool?).
 - ✘ Check for a correct mounting of the welding lead. Fit the feeder clamp of the welding lead as close as possible to the arc.

Excess temperature signal light illuminates

- ↗ Excess temperature, welding machine
 - ✘ Allow the machine to cool down whilst still switched on

Functional errors

- ✓ Mains fuse triggers - unsuitable mains fuse
 - ✘ Set up recommended mains fuse > see 8 chapter.
- ✓ Machine does not start up after switching on (device fan and possibly coolant pump have no function).
 - ✘ Connect the control cable of the wire feeder.
- ✓ All machine control signal lights are illuminated after switching on
- ✓ No machine control signal light is illuminated after switching on
- ✓ No welding power
 - ✘ Phase failure > check mains connection (fuses)
- ✓ Machine restarts continuously
- ✓ Wire feeder without function
- ✓ System does not start up
 - ✘ Make control lead connections and check that they are fitted correctly.
- ✓ Loose welding current connections
 - ✘ Tighten power connections on the torch and/or on the workpiece
 - ✘ Properly fasten the contact tip and contact tip holder.

Wire feed problems

- ✓ Contact tip blocked
 - ✘ Clean and, if necessary, replace.
- ✓ Setting the spool brake > see 5.2.2.4 chapter
 - ✘ Check settings and correct if necessary
- ✓ Setting pressure units > see 5.2.2.3 chapter
 - ✘ Check settings and correct if necessary
- ✓ Worn wire rolls
 - ✘ Check and replace if necessary
- ✓ Kinked hose packages
 - ✘ Extend and lay out the torch hose package
- ✓ Wire guide core or spiral is dirty or worn
 - ✘ Clean core or spiral; replace kinked or worn cores

7.4 Dynamic power adjustment

This requires use of the appropriate mains fuse.

Observe mains fuse specification > see 8 chapter!

The dynamic power adjustment automatically adjusts the welding performance to an uncritical level for the fuse.

The dynamic power adjustment can be set in two increments in the machine configuration menu using parameter "FUS": 20 A, 16 A.

The currently selected value will be shown on the "cal" section of the display for three seconds after the machine has been switched on.

7.5 Resetting welding parameters to the factory settings

All customised welding parameters that are stored will be replaced by the factory settings.

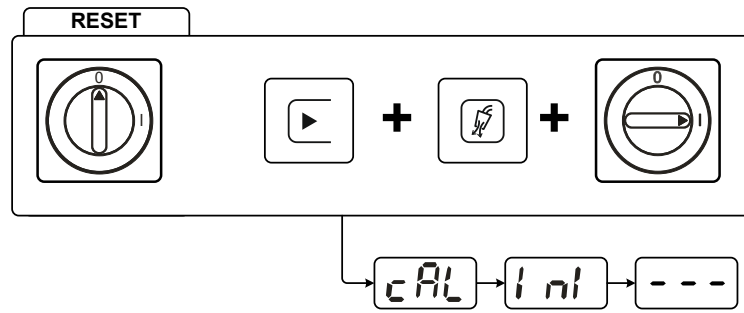





Figure 7-1

Display	Setting/selection
	Calibration The machine will be calibrated for approx 2 seconds each time it is switched on.
	Initialising Keep the push-button pressed until is shown on the display.

8 Technical data

Performance specifications and guarantee only in connection with original spare and replacement parts!

8.1 Picomig 225

	MIG/MAG	TIG	MMA
Welding current (I ₂)	5 A to 220 A	5 A to 230 A	5 A to 180 A
Welding voltage according to standard (U ₂)	14,3 V to 25 V	10,2 V to 19,2 V	20,2 V to 27,2 V
Duty cycle DC at 40° C ^[1]	220 A (30 %) 170 A (60 %) 150 A (100 %)	230 A (35 %) 200 A (60 %) 170 A (100 %)	180 A (35 %) 150 A (60 %) 130 A (100 %)
Open circuit voltage (U ₀)	70 V		
Mains voltage (Tolerance)	1 x 230 V (-40 % to +15 %)		
Frequency	50/60 Hz		
mains fuse ^[2]	1 x 16 A		
Mains connection cable	H07RN-F3G2,5		
Connected load (S ₁)	6,5 kVA	5,2 kVA	5,8 kVA
Generator rating (Rec.)	8,8 kVA		
Power consumption P _i	15 W		
Cos φ / efficiency	0,99 / 86 %		
Protection class / Overvoltage category	I / III		
Contamination level	3		
Insulation class / protection classification	H / IP 23		
Residual current circuit breaker	Type B (recommended)		
Noise level ^[3]	<70 dB(A)		
Ambient temperature ^[4]	-25 °C to +40 °C		
Machine cooling / Torch cooling	Fan (AF) / gas		
Wire feed speed	1 m/min to 18 m/min / 39.37 ipm to 708.66 ipm		
Factory-installed roll equipment	0,8/1,0 mm for steel wire		
Drive	4 rollers (37 mm)		
Wire spool diameter	Standardised wire spools up to 300 mm		
Welding torch connection	Euro torch connector		
Workpiece lead (min.)	35 mm ²		
EMC class	A		
Test mark	 /  /  / 		
Standards used	See declaration of conformity (appliance documents)		
Dimensions (l x b x h)	636 x 298 x 482 mm 25.0 x 11.7 x 19.0 inch		
Weight	24 kg 52.9 lb.		

^[1] Load cycle: 10 min. (60 % DC \triangleq 6 min. welding, 4 min. pause)

^[2] Safety fuses are recommended DIAZED xxA gG. When using automatic cutouts, the "C" trigger characteristic must be used.

^[3] Noise level during idle mode and operation under standard load according to IEC 60974-1 at the maximum operating point.

^[4] Ambient temperature dependent on coolant! Observe coolant temperature range!

9 Accessories

Performance-dependent accessories like torches, workpiece leads, electrode holders or intermediate hose packages are available from your authorised dealer.

9.1 Transport system

Type	Designation	Item no.
Trolley 35.2-2	Transport vehicle	090-008296-00000
Trolley 55-5	Transport cart, assembled	090-008632-00000
Trolley 55-6	Transport cart, assembled	090-008825-00000
ON TR Trolley 55-5 / 55-6	Cross arm and holder for wire feeder	092-002700-00000

9.2 Options

Type	Designation	Item no.
ON XNET PICOMIG 3XX	Retrofit option for connection to EWM Xnet over Xnet LAN/Wi-Fi gateway	092-004004-00000
ON D Barrel TG.0003	Wire guide Rolliner for drum feed	092-007929-00000
ON Case	Tool box for mounting to trolley Trolley 55-5 / Trolley 55-6	092-002899-00000
AK300	Wire spool adapter K300	094-001803-00001
ON CS T.005/TG.0003/D.0002	Crane suspension for Picomig 180 / 185 D3 / 305 D3, Phoenix and Taurus 355 compact, drive 4	092-002549-00000
ON TH TG.03/TG.04/TG.11 R	Torch holder, right	092-002699-00000
CA D200	Centering adapter for 5-kg spools	094-011803-00000
ON WAK TG.03/TG.04/TG.09/K.02	Wheel assembly kit	092-001356-00000
ON Filter TG.0003	Dirt filter	092-002662-00000

9.3 General accessories

Type	Designation	Item no.
AK300	Wire spool adapter K300	094-001803-00001
CA D200	Centering adapter for 5-kg spools	094-011803-00000
SKGS 16A 250V CEE7/7, DIN 49440/441	Safety plug	094-001756-00000
ADAP CEE16/SCHUKO	Earth contact coupling/CEE16A plug	092-000812-00000
DM 842 Ar/CO2 230bar 30l D	Pressure regulator with manometer	394-002910-00030
G1 G1/4 R 3M	Gas hose	094-000010-00003
DSP	Sharpener for liner	094-010427-00000
Cutter	Hose cutter	094-016585-00000
voltConverter 230/400	Voltage converter	090-008800-00502
ON AL D13/27	Cap for load sockets	092-003282-00000
ADAPTER EZA --> DINSE-ZA	Adapter for welding torches with Dinse connector to Euro central connector, on the machine	094-016765-00000

10 Replaceable parts

Performance specifications and guarantee only in connection with original spare and replacement parts!

10.1 Wire feed rollers

10.1.1 Wire feed rollers for steel wire

Type	Designation	Item no.
FE 4R 0.6 MM/0.023 INCH LIGHT PINK	Drive roll set, 37 mm, 4 rolls, V-groove for steel, stainless steel and brazing	092-002770-00006
FE 4R 0.8-1.0MM / 0.03-0.04 INCH BLUE/WHITE	Drive roll set, 37 mm, 4 rolls, V-groove for steel, stainless steel and brazing	092-002770-00009
FE 4R 1.0-1.2MM / 0.04-0.045 INCH BLUE/RED	Drive roll set, 37 mm, 4 rolls, V-groove for steel, stainless steel and brazing	092-002770-00011
FE 4R 1.4 MM/0.052 INCH GREEN	Drive roll set, 37 mm, 4 rolls, V-groove for steel, stainless steel and brazing	092-002770-00014
FE 4R 1.6 MM/0.06 INCH BLACK	Drive roll set, 37 mm, 4 rolls, V-groove for steel, stainless steel and brazing	092-002770-00016
FE 4R 2.0 MM/0.08 INCH GREY	Drive roll set, 37 mm, 4 rolls, V-groove for steel, stainless steel and brazing	092-002770-00020
FE 4R 2.4 MM/0.095 INCH BROWN	Drive roll set, 37 mm, 4 rolls, V-groove for steel, stainless steel and brazing	092-002770-00024
FE 4R 2.8 MM/0.11 INCH LIGHT GREEN	Drive roll set, 37 mm, 4 rolls, V-groove for steel, stainless steel and brazing	092-002770-00028
FE 4R 3.2 MM/0.12 INCH VIOLET	Drive roll set, 37 mm, 4 rolls, V-groove for steel, stainless steel and brazing	092-002770-00032

10.1.2 Wire feed rollers for aluminium wire

Type	Designation	Item no.
AL 4R 0.8 MM/0.03 INCH WHITE/YELLOW	Drive roll set, 37 mm, for aluminium	092-002771-00008
AL 4R 1.0 MM/0.04 INCH BLUE/YELLOW	Drive roll set, 37 mm, for aluminium	092-002771-00010
AL 4R 1.2 MM/0.045 INCH RED/YELLOW	Drive roll set, 37 mm, for aluminium	092-002771-00012
AL 4R 1.6 MM/0.06 INCH BLACK/YELLOW	Drive roll set, 37 mm, for aluminium	092-002771-00016
AL 4R 2.0 MM/0.08 INCH GREY/YELLOW	Drive roll set, 37 mm, for aluminium	092-002771-00020
AL 4R 2.4 MM/0.095 INCH BROWN/YELLOW	Drive roll set, 37 mm, for aluminium	092-002771-00024
AL 4R 2.8 MM/0.110 INCH LIGHT GREEN/YELLOW	Drive roll set, 37 mm, for aluminium	092-002771-00028
AL 4R 3.2 MM/0.125 INCH VIOLET/YELLOW	Drive roll set, 37 mm, for aluminium	092-002771-00032

10.1.3 Wire feed rollers for cored wire

Type	Designation	Item no.
FUEL 4R 0.8 MM/0.03 INCH WHITE/ORANGE	Drive roll set, 37 mm, 4 rolls, V-groove/knurled for flux cored wire	092-002848-00008
FUEL 4R 1.0 MM/0.04 INCH BLUE/ORANGE	Drive roll set, 37 mm, 4 rolls, V-groove/knurled for flux cored wire	092-002848-00010
FUEL 4R 1.2 MM/0.045 INCH RED/ORANGE	Drive roll set, 37 mm, 4 rolls, V-groove/knurled for flux cored wire	092-002848-00012
FUEL 4R 1.4 MM/0.052 INCH GREEN/ORANGE	Drive roll set, 37 mm, 4 rolls, V-groove/knurled for flux cored wire	092-002848-00014
FUEL 4R 1.6 MM/0.06 INCH BLACK/ORANGE	Drive roll set, 37 mm, 4 rolls, V-groove/knurled for flux cored wire	092-002848-00016
FUEL 4R 2.0 MM/0.08 INCH GREY/ORANGE	Drive roll set, 37 mm, 4 rolls, V-groove/knurled for flux cored wire	092-002848-00020
FUEL 4R 2.4 MM/0.095 INCH BROWN/ORANGE	Drive roll set, 37 mm, 4 rolls, V-groove/knurled for flux cored wire	092-002848-00024

10.1.4 Wire guide

Type	Designation	Item no.
DV X	Wire feed roll mount set	092-002960-E0000
SET DRAHTFUERUNG	Wire guide set	092-002774-00000
ON WF 2,0-3,2mm eFeed	Retrofitting option, wire guide for 2.0–3.2 mm wires, eFeed drive	092-019404-00000
SET IG 4x4 1.6mm BL	Inlet guide set	092-002780-00000
GUIDE TUBE L105	Guide tube	094-006051-00000
CAPTUB L=107 mm; Ø ≤ 1,6 mm	Capillary tube	094-006634-00000
CAPTUB L=105 mm; Ø ≤ 2,4 mm	Capillary tube	094-021470-00000

11 Appendix

11.1 Searching for a dealer

Sales & service partners
www.ewm-group.com/en/specialist-dealers



"More than 400 EWM sales partners worldwide"