



EN

Transport systems

Trolley 55-6
Trolley 55-6 DF

099-008825-EW501

Observe additional system documents!

13.6.2023

**Register now
and benefit!**
**Jetzt Registrieren
und Profitieren!**

www.ewm-group.com



General instructions

WARNING



Read the operating instructions!

The operating instructions provide an introduction to the safe use of the products.

- Read and observe the operating instructions for all system components, especially the safety instructions and warning notices!
- Observe the accident prevention regulations and any regional regulations!
- The operating instructions must be kept at the location where the machine is operated.
- Safety and warning labels on the machine indicate any possible risks. Keep these labels clean and legible at all times.
- The machine has been constructed to state-of-the-art standards in line with any applicable regulations and industrial standards. Only trained personnel may operate, service and repair the machine.
- Technical changes due to further development in machine technology may lead to a differing welding behaviour.

In the event of queries on installation, commissioning, operation or special conditions at the installation site, or on usage, please contact your sales partner or our customer service department on +49 2680 181-0.

A list of authorised sales partners can be found at www.ewm-group.com/en/specialist-dealers.

Liability relating to the operation of this equipment is restricted solely to the function of the equipment. No other form of liability, regardless of type, shall be accepted. This exclusion of liability shall be deemed accepted by the user on commissioning the equipment.

The manufacturer is unable to monitor whether or not these instructions or the conditions and methods are observed during installation, operation, usage and maintenance of the equipment.

An incorrectly performed installation can result in material damage and injure persons as a result. For this reason, we do not accept any responsibility or liability for losses, damages or costs arising from incorrect installation, improper operation or incorrect usage and maintenance or any actions connected to this in any way.

© EWM GmbH

Dr. Günter-Henle-Strasse 8

56271 Mündersbach Germany

Tel.: +49 2680 181-0, Fax: -244

Email: info@ewm-group.com

www.ewm-group.com

The copyright to this document remains the property of the manufacturer.

Copying, including extracts, only permitted with written approval.

The content of this document has been prepared and reviewed with all reasonable care. The information provided is subject to change; errors excepted.

Data security

The user is responsible for backing up data of all changes from the factory setting. The user is liable for erased personal settings. The manufacturer does not assume any liability for this.

1 Contents

1	Contents	3
2	For your safety	4
2.1	Notes on using these operating instructions.....	4
2.2	Explanation of icons.....	5
2.3	Safety instructions.....	6
2.4	Transport and installation	9
3	Intended use	11
3.1	Applications.....	11
3.2	Use and operation solely with the following machines	11
4	Machine description – quick overview	12
4.1	Front view / side view from the right	12
5	Design and function	13
5.1	System overview.....	13
5.2	Attach the system component to the transport cart	15
5.2.1	Intermediate hose package strain relief	18
5.2.1.1	Locking the strain relief	18
5.3	Securing the shielding gas cylinder	19
5.3.1	Attach the clamping belt to secure the shielding gas cylinder.....	20
5.3.1.1	Trolley 55-6	20
5.3.1.2	Trolley 55-6 DF	21
5.4	Using the transport system	22
5.4.1	Lifting by crane	22
5.4.2	Craning principle.....	23
6	Maintenance, care and disposal	24
6.1	General	24
6.1.1	Cleaning	24
6.1.2	Dirt filter	24
6.2	Maintenance work, intervals	25
6.2.1	Daily maintenance tasks.....	25
6.2.2	Monthly maintenance tasks.....	25
6.2.3	Annual test (inspection and testing during operation).....	25
6.3	Disposing of equipment	26
7	Technical data	27
7.1	Trolley 55-6 / Trolley 55-6 DF	27
8	Accessories	28
8.1	Options.....	28
9	Appendix	29
9.1	Searching for a dealer.....	29

2 For your safety

2.1 Notes on using these operating instructions

DANGER

Working or operating procedures which must be closely observed to prevent imminent serious and even fatal injuries.

- Safety notes include the "DANGER" keyword in the heading with a general warning symbol.
- The hazard is also highlighted using a symbol on the edge of the page.

WARNING

Working or operating procedures which must be closely observed to prevent serious and even fatal injuries.

- Safety notes include the "WARNING" keyword in the heading with a general warning symbol.
- The hazard is also highlighted using a symbol in the page margin.

CAUTION

Working or operating procedures which must be closely observed to prevent possible minor personal injury.

- The safety information includes the "CAUTION" keyword in its heading with a general warning symbol.
- The risk is explained using a symbol on the edge of the page.



Technical aspects which the user must observe to avoid material or equipment damage.

Instructions and lists detailing step-by-step actions for given situations can be recognised via bullet points, e.g.:

- Insert the welding current lead socket into the relevant socket and lock.

2.2 Explanation of icons

Symbol	Description	Symbol	Description
	Indicates technical aspects which the user must observe.		Activate and release / Tap / Tip
	Switch off machine		Release
	Switch on machine		Press and hold
	Incorrect / Invalid		Switch
	Correct / Valid		Turn
	Input		Numerical value – adjustable
	Navigation		Signal light lights up in green
	Output		Signal light flashes green
	Time representation (e.g.: wait 4 s / actuate)		Signal light lights up in red
	Interruption in the menu display (other setting options possible)		Signal light flashes red
	Tool not required/do not use		Signal light lights up in blue
	Tool required/use		Signal light flashes blue

2.3 Safety instructions

WARNING



Risk of accidents due to non-compliance with the safety instructions!

Non-compliance with the safety instructions can be fatal!

- Carefully read the safety instructions in this manual!
- Observe the accident prevention regulations and any regional regulations!
- Inform persons in the working area that they must comply with the regulations!



Risk of injury from electrical voltage!

Voltages can cause potentially fatal electric shocks and burns on contact. Even low voltages can cause a shock and lead to accidents.

- Never touch live components such as welding current sockets or stick, tungsten or wire electrodes!
- Always place torches and electrode holders on an insulated surface!
- Wear the full personal protective equipment (depending on the application)!
- The machine may only be opened by qualified personnel!
- The device must not be used to defrost pipes!

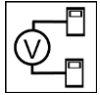

Hazard when interconnecting multiple power sources!

If a number of power sources are to be connected in parallel or in series, only a technical specialist may interconnect the sources as per standard IEC 60974-9:2010: Installation and use and German Accident Prevention Regulation BVG D1 (formerly VBG 15) or country-specific regulations.

Before commencing arc welding, a test must verify that the equipment cannot exceed the maximum permitted open circuit voltage.

- Only qualified personnel may connect the machine.
- When taking individual power sources out of operation, all mains and welding current leads must be safely disconnected from the welding system as a whole. (Hazard due to reverse polarity voltage!)
- Do not interconnect welding machines with pole reversing switch (PWS series) or machines for AC welding since a minor error in operation can cause the welding voltages to be combined, which is not permitted.



Risk of injury due to radiation or heat!

Arc radiation can lead to skin and eye injuries.

Contact with hot workpieces and sparks can lead to burns.

- Use hand shield or welding helmet with the appropriate safety level (depends on the application).
- Wear dry protective clothing (e.g. hand shield, gloves, etc.) in accordance with the applicable regulations of your country.
- Persons who are not directly involved should be protected with a welding curtain or suitable safety screen against radiation and the risk of blinding!

⚠ WARNING**Risk of injury due to improper clothing!**

During arc welding, radiation, heat and voltage are sources of risk that cannot be avoided. The user has to be equipped with the complete personal protective equipment at all times. The protective equipment has to include:

- Respiratory protection against hazardous substances and mixtures (fumes and vapours); otherwise implement suitable measures such as extraction facilities.
- Welding helmet with proper protection against ionizing radiation (IR and UV radiation) and heat.
- Dry welding clothing (shoes, gloves and body protection) to protect against warm environments with conditions comparable to ambient temperatures of 100 °C or higher and arcing and work on live components.
- Hearing protection against harming noise.

**Explosion risk!**

Apparently harmless substances in closed containers may generate excessive pressure when heated.

- Move containers with inflammable or explosive liquids away from the working area!
- Never heat explosive liquids, dusts or gases by welding or cutting!

**Fire hazard!**

Due to the high temperatures, sparks, glowing parts and hot slag that occur during welding, there is a risk of flames.

- Be watchful of potential sources of fire in the working area!
- Do not carry any easily inflammable objects, e.g. matches or lighters.
- Ensure suitable fire extinguishers are available in the working area!
- Thoroughly remove any residue of flammable materials from the workpiece prior to starting to weld.
- Only further process workpieces after they have cooled down. Do not allow them to contact any flammable materials!

⚠ CAUTION



Smoke and gases!

Smoke and gases may lead to shortness of breath and poisoning! The ultraviolet radiation of the arc may also convert solvent vapours (chlorinated hydrocarbon) into poisonous phosgene.

- Ensure sufficient fresh air!
- Keep solvent vapours away from the arc beam field!
- Wear suitable respiratory protection if necessary!
- To prevent the formation of phosgene, residues of chlorinated solvents on workpieces must first be neutralised using appropriate measures.



Noise exposure!

Noise exceeding 70 dBA can cause permanent hearing damage!

- Wear suitable ear protection!
- Persons located within the working area must wear suitable ear protection!



According to IEC 60974-10, welding machines are divided into two classes of electromagnetic compatibility (the EMC class can be found in the Technical data) > see 7 chapter:

Class A machines are not intended for use in residential areas where the power supply comes from the low-voltage public mains network. When ensuring the electromagnetic compatibility of class A machines, difficulties can arise in these areas due to interference not only in the supply lines but also in the form of radiated interference.



Class B machines fulfil the EMC requirements in industrial as well as residential areas, including residential areas connected to the low-voltage public mains network.



Setting up and operating

When operating arc welding systems, in some cases, electro-magnetic interference can occur although all of the welding machines comply with the emission limits specified in the standard. The user is responsible for any interference caused by welding.

In order to **evaluate** any possible problems with electromagnetic compatibility in the surrounding area, the user must consider the following: (see also EN 60974-10 Appendix A)

- Mains, control, signal and telecommunication lines
- Radios and televisions
- Computers and other control systems
- Safety equipment
- The health of neighbouring persons, especially if they have a pacemaker or wear a hearing aid
- Calibration and measuring equipment
- The immunity to interference of other equipment in the surrounding area
- The time of day at which the welding work must be carried out

Recommendations for **reducing interference emission**

- Mains connection, e.g. additional mains filter or shielding with a metal tube
- Maintenance of the arc welding system
- Welding leads should be as short as possible and run closely together along the ground
- Potential equalization
- Earthing of the workpiece. In cases where it is not possible to earth the workpiece directly, it should be connected by means of suitable capacitors.
- Shielding from other equipment in the surrounding area or the entire welding system



Electromagnetic fields!

The power source can create electrical or electromagnetic fields that may impair the function of electronic systems such as EDP and CNC devices, telecommunication, power and signal lines as well as pacemakers and defibrillators.



- Follow the maintenance instructions > see 6 chapter!
- Unwind the welding leads completely!
- Shield radiation-sensitive equipment or facilities appropriately!
- The function of pacemakers may be impaired (seek medical advice if necessary).

 **CAUTION****Obligations of the operator!**

The respective national directives and laws must be complied with when operating the machine!

- Implementation of national legislation relating to framework directive 89/391/EEC on the introduction of measures to encourage improvements in the safety and health of workers at work and associated individual guidelines.
- In particular, directive 89/655/EEC concerning the minimum safety and health requirements for the use of work equipment by workers at work.
- The regulations applicable to occupational safety and accident prevention in the country concerned.
- Setting up and operating the machine as per IEC 60974.-9.
- Brief the user on safety-conscious work practices on a regular basis.
- Regularly inspect the machine as per IEC 60974.-4.



The manufacturer's warranty becomes void if non-genuine parts are used!

- ***Only use system components and options (power sources, welding torches, electrode holders, remote controls, spare parts and replacement parts, etc.) from our range of products!***
- ***Only insert and lock accessory components into the relevant connection socket when the machine is switched off.***

Requirements for connection to the public mains network

High-performance machines can influence the mains quality by taking current from the mains network. For some types of machines, connection restrictions or requirements relating to the maximum possible line impedance or the necessary minimum supply capacity at the interface with the public network (Point of Common Coupling, PCC) can therefore apply. In this respect, attention is also drawn to the machines' technical data. In this case, it is the responsibility of the operator, where necessary in consultation with the mains network operator, to ensure that the machine can be connected.

2.4 Transport and installation

 **WARNING****Risk of injury due to improper handling of shielding gas cylinders!**

Improper handling and insufficient securing of shielding gas cylinders can cause serious injuries!

- Observe the instructions from the gas manufacturer and any relevant regulations concerning the use of compressed air!
- Do not attach any element to the shielding gas cylinder valve!
- Prevent the shielding gas cylinder from heating up.

CAUTION



Risk of accidents due to supply lines!

During transport, attached supply lines (mains leads, control cables, etc.) can cause risks, e.g. by causing connected machines to tip over and injure persons!

- Disconnect all supply lines before transport!



Risk of tipping!

There is a risk of the machine tipping over and injuring persons or being damaged itself during movement and set up. Tilt resistance is guaranteed up to an angle of 10° (according to IEC 60974-1).

- Set up and transport the machine on level, solid ground.
- Secure add-on parts using suitable equipment.



Risk of accidents due to incorrectly installed leads!

Incorrectly installed leads (mains, control and welding leads or intermediate hose packages) can present a tripping hazard.

- Lay the supply lines flat on the floor (avoid loops).
- Avoid laying the leads on passage ways.



Risk of injury from heated coolant and its connections!

The coolant used and its connection or connection points can heat up significantly during operation (water-cooled version). When opening the coolant circuit, escaping coolant may cause scalding.

- Open the coolant circuit only when the power source or cooling unit is switched off!
- Wear proper protective equipment (protective gloves)!
- Seal open connections of the hose leads with suitable plugs.



The units are designed for operation in an upright position!

Operation in non-permissible positions can cause equipment damage.

- ***Only transport and operate in an upright position!***



Accessory components and the power source itself can be damaged by incorrect connection!

- ***Only insert and lock accessory components into the relevant connection socket when the machine is switched off.***
- ***Comprehensive descriptions can be found in the operating instructions for the relevant accessory components.***
- ***Accessory components are detected automatically after the power source is switched on.***



Protective dust caps protect the connection sockets and therefore the machine against dirt and damage.

- ***The protective dust cap must be fitted if there is no accessory component being operated on that connection.***
- ***The cap must be replaced if faulty or if lost!***

3 Intended use

WARNING



Hazards due to improper usage!

The machine has been constructed to the state of the art and any regulations and standards applicable for use in industry and trade. It may only be used for the welding procedures indicated at the rating plate. Hazards may arise for persons, animals and material objects if the equipment is not used correctly. No liability is accepted for any damages arising from improper usage!

- The equipment must only be used in line with its designated purpose and by trained or expert personnel!
- Do not improperly modify or convert the equipment!

3.1 Applications

For transporting arc welding systems and process-dependent components such as torch cooling modules or shielding gas cylinders.

3.2 Use and operation solely with the following machines

- Tetric 230, 300 DC Comfort 2.0 / Smart 2.0
- Tetric 230, 300 AC/DC Comfort 2.0 / Smart 2.0
- Taurus 355, 405, 505
- Taurus 355 TKM
- Phoenix 355, 405, 505 TDM
- Phoenix 355 TKM
- Microplasma 25, 55, 105
- Picotig 200 AC/DC
- Picomig 185 TKG
- Picomig 355 TKM
- Cool 40, 50
- ON Case
- voltConverter 230/400

For systems equipped with a wire feeder, additional options have to be retro-fitted. See the system overview for the relevant options and combinations > see 5.1 chapter.

4 Machine description – quick overview

4.1 Front view / side view from the right

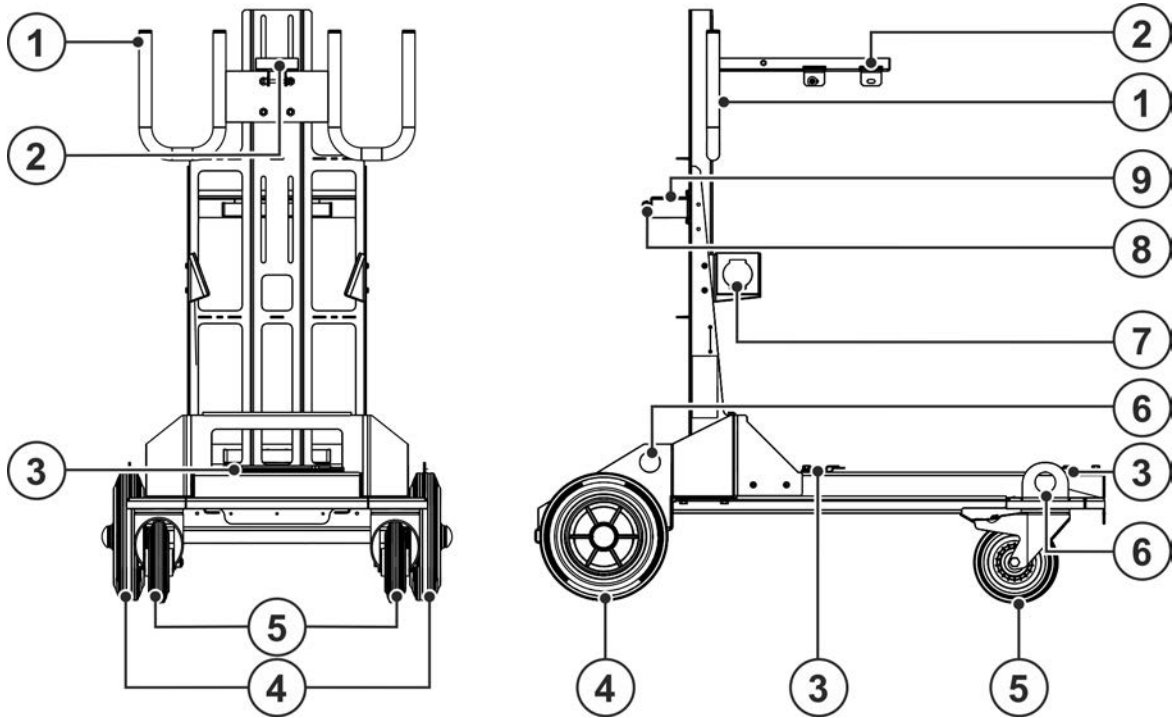

Figure 4-1

Item	Symbol	Description
1		Hose package holder
2		Cross arm Upper device attachment
3		Machine mounting attachment
4		Transport wheel
5		Wheels, guide castors
6		Lifting lug > see 5.4.1 chapter
7		Intermediate hose package strain relief > see 5.2.1 chapter
8		Safety element for shielding gas cylinder Clamping belt for securing the shielding gas cylinder > see 5.3.1 chapter.
9		Holder for shielding gas cylinder

5 Design and function

5.1 System overview

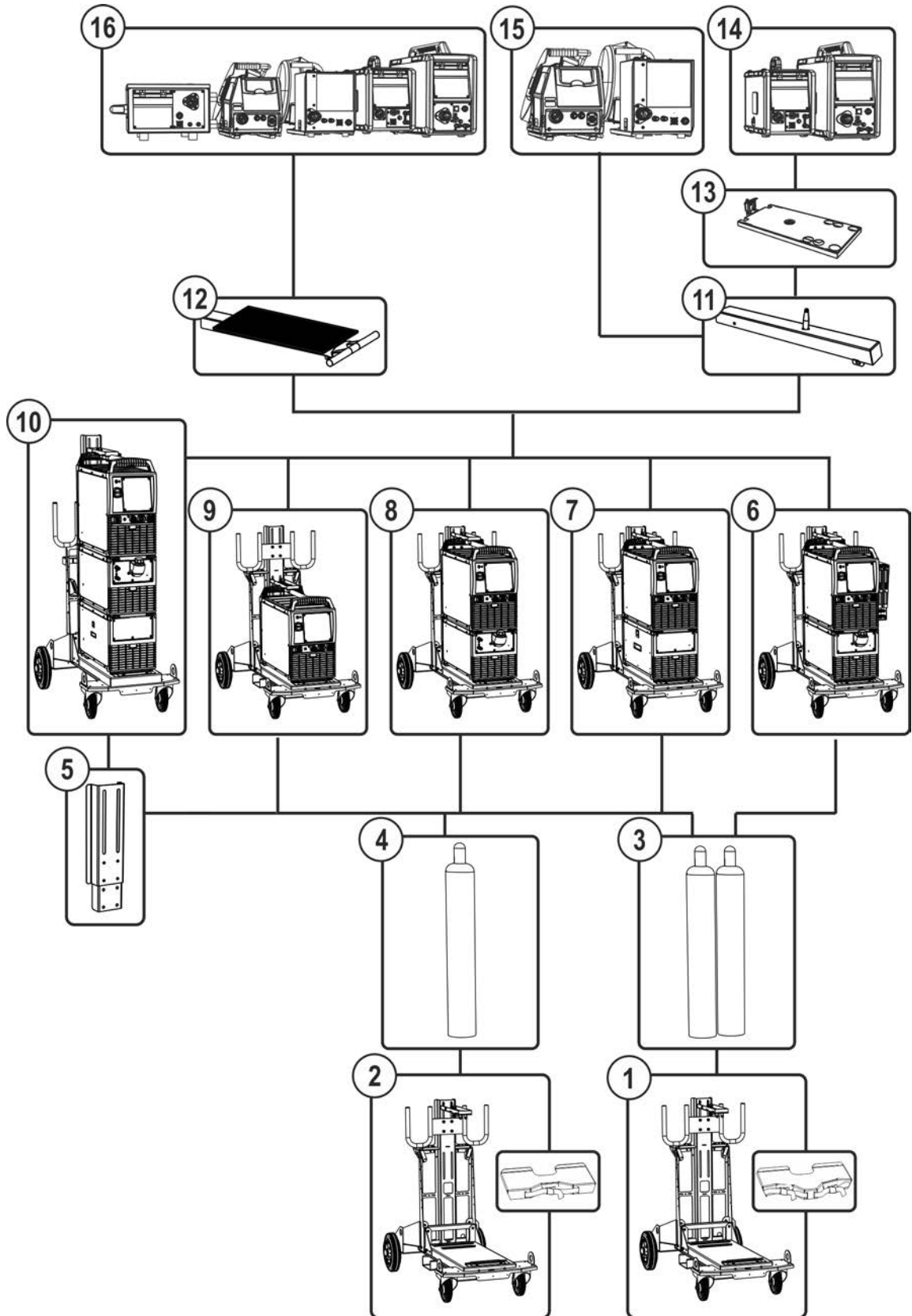

Figure 5-1

Item	Symbol	Description
1		Transport vehicle - Trolley 55-6 DF
2		Transport vehicle - Trolley 55-6
3		Shielding gas cylinder
4		Shielding gas cylinder
5		Extension of the Trolley's cross arm to accommodate added modules - ON Extender 092-003507-00000
6		Transport cart - Trolley 55-6 + power source Microplasma + cooling module
7		Transport cart – Trolley 55-6 + power source + ON TC 092-002899-00000
8		Transport vehicles - Trolley 55-6 + Power source + cool
9		Transport vehicles - Trolley 55-6 + Power source
10		transport cart - Trolley 55-6 + power source + cooling module + ON TC 092- 002899-00000
11		ON PS Trolley 55-5 / 55-6 Pivot support (360°) for wire feeders - 092-002712-00000
12		ON TR Trolley 55-5 / 55-6 Cross arm and holder for wire feeder - 092-002700-00000
13		ON PS Trolley 55-5 / 55-6 drive D200 Pivot support for D200 wire feeders - 092-002634-00000
14		Wire feeders - drive 200/300C (rotatable)
15		Wire feeders - drive 4L/4X (rotatable)
16		All wire feeders - drive

5.2 Attach the system component to the transport cart

⚠ CAUTION



Risk of accidents due to supply lines!

During transport, attached supply lines (mains leads, control cables, etc.) can cause risks, e.g. by causing connected machines to tip over and injure persons!

- Disconnect all supply lines before transport!

This transport system is designed to accommodate modular device systems.

The standard version allows the fitting of up to two system components (e.g. power source and cooling module or an identical module) to the transport cart. The modules are attached to the transport cart using device-dependent support brackets and the height-adjustable cross arm.

Attaching added options allows the combination of further devices or modules > see 5.1 chapter.

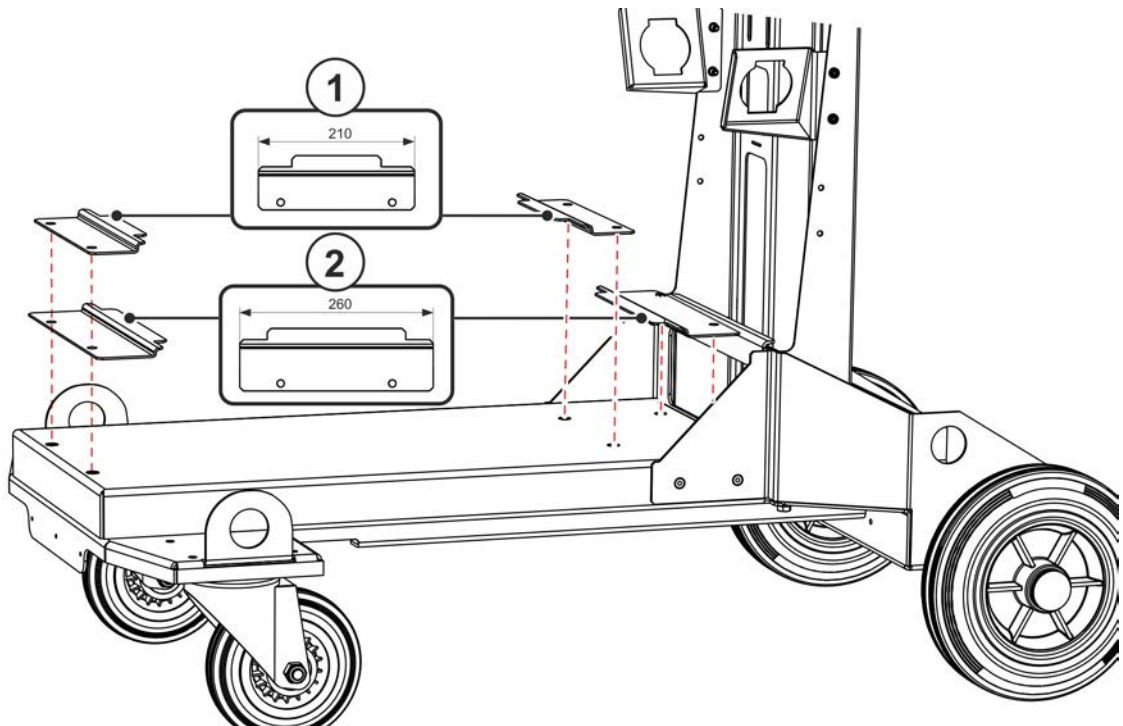

Figure 5-2

Item	Symbol	Description
1		Support bracket (BK210) Lower device fixation
2		Support bracket (BK260) Lower device fixation

- Unscrew the support bracket.
The further use of the support bracket depends on the system components to be used (please note the device assignment of the support bracket BK260/BK210). The attachment with the front and rear support brackets BK260 is shown below as an example.

Depending on the power source or cooling module to be installed, different holding plates are required at the shown positions.

Support bracket assignment	BK210	BK260
Taurus 355, 405, 505	✘	✔
Phoenix 355, 405, 505	✘	✔
Microplasma 25, 55, 105	✘	✔
Picomig 185, 355	✘	✔
Cool 50	✘	✔
ON Case	✘	✔
voltConverter 230/400	✘	✔
Picotig 200 AC/DC	✔	✘
Tetrix 230, 300 Comfort 2.0 / Smart 2.0	✔	✘
Cool 40	✔	✘

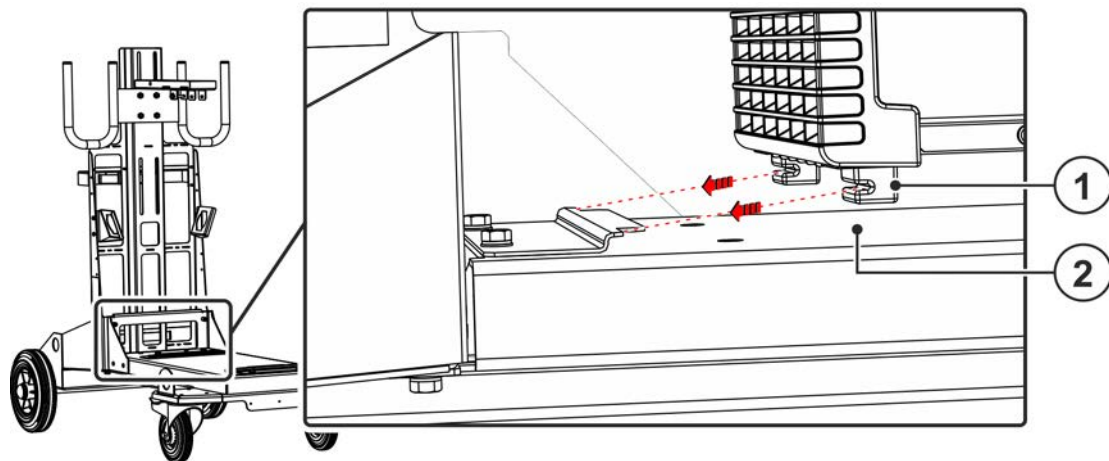

Figure 5-3

Item	Symbol	Description
1		Machine feet
2		Machine support

- Place the machine with its feet in the recesses provided.

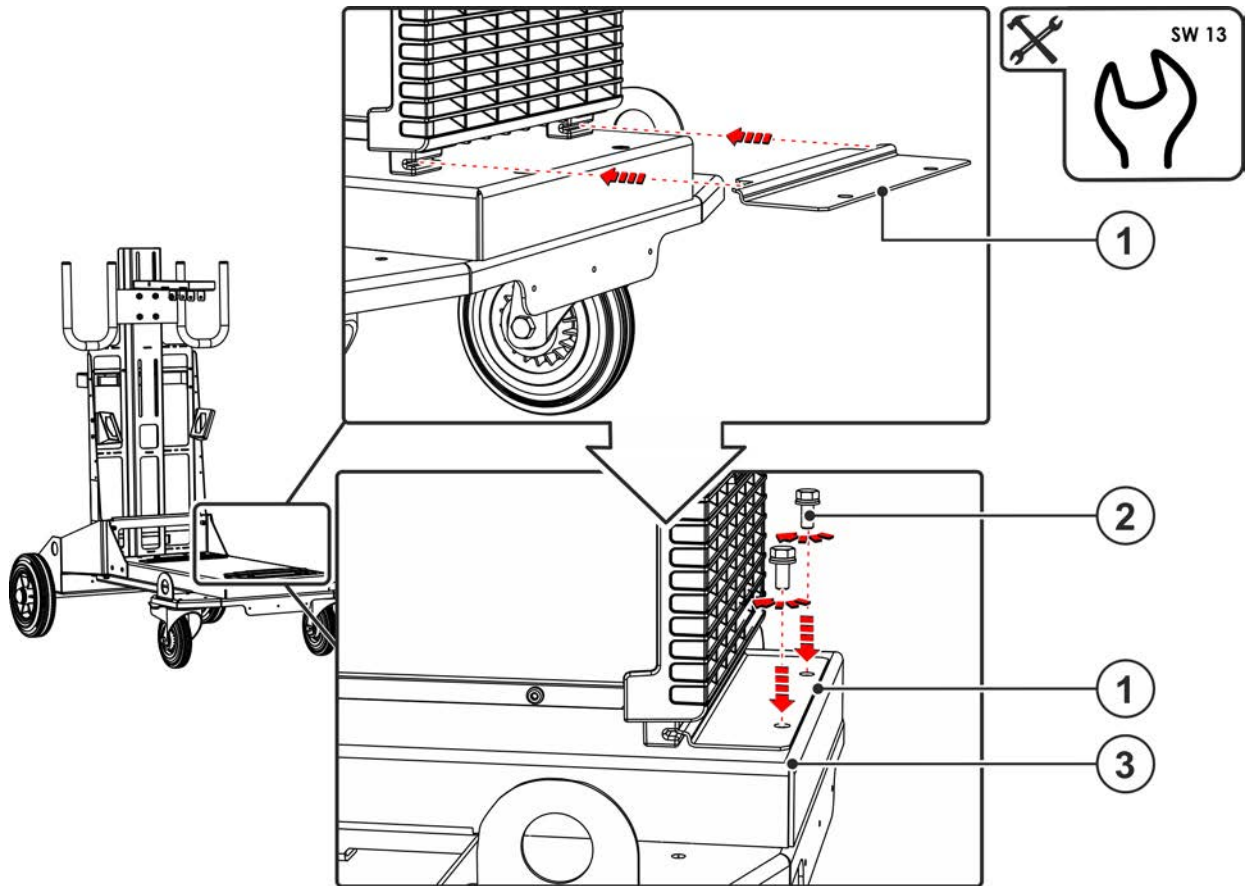

Figure 5-4

Item	Symbol	Description
1		Machine mounting attachment
2		Hexagonal screw M8 x 20
3		Machine support

- Mount the machine mounting attachment with hexagonal screws on the machine support.

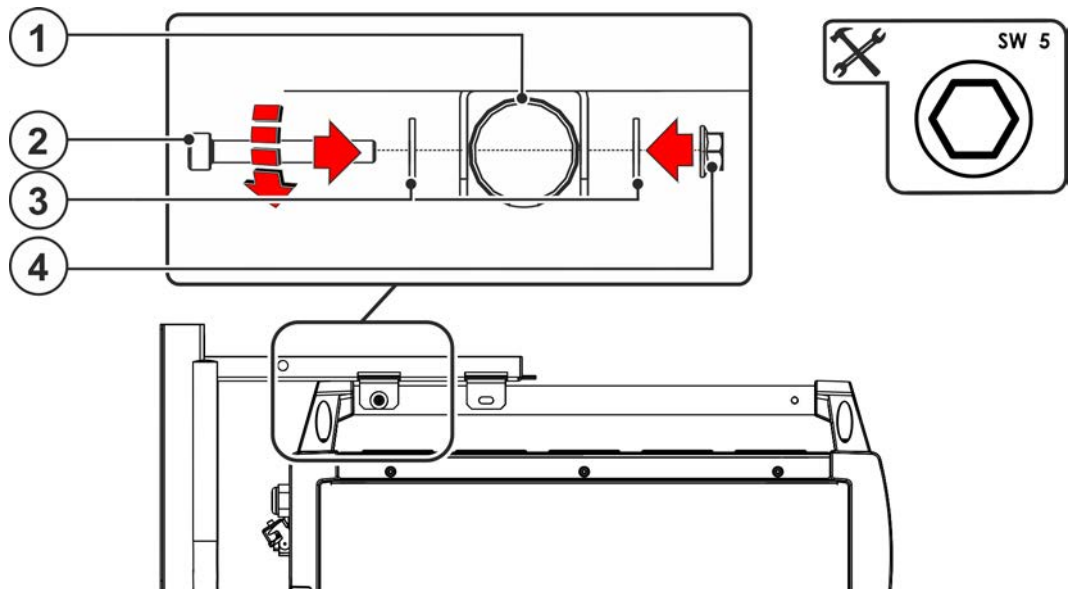

Figure 5-5

Item	Symbol	Description
1		Transport bar
2		Allen screw

Item	Symbol	Description
3		Plain washer
4		Hexagon nut

- Mount transport bar with fastening material and wire feeder machine support.

5.2.1 Intermediate hose package strain relief



Property damage due to strain relief not installed or not installed correctly!

The strain relief absorbs tensile forces on cables, plugs and sockets.

If strain reliefs are not installed or not installed correctly, the connector plugs or sockets may be damaged.

- **The attachment must always take place on both sides of the intermediate hose package!**
- **The connections of the hose package must be locked properly!**

5.2.1.1 Locking the strain relief

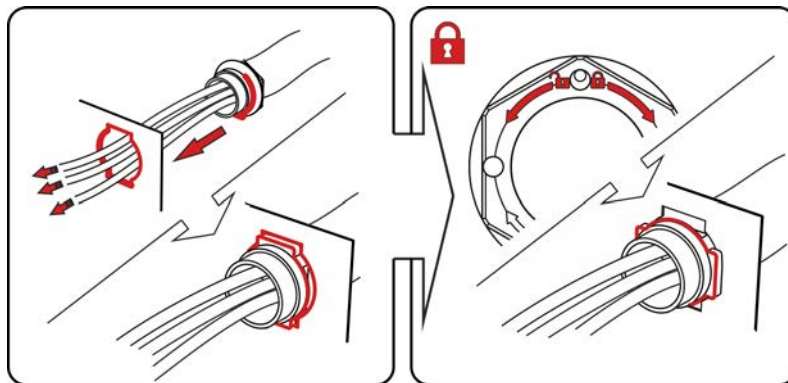

Figure 5-6

- Insert the end of the hose package through the strain relief of the hose package and lock by turning to the right.

5.3 Securing the shielding gas cylinder

⚠ WARNING



Risk of accident due to improperly secured shielding gas cylinder!

Improper or inadequate securing of shielding gas cylinders can result in severe injury.

- A shielding gas cylinder must be secured with at least two clamping belts!
- Make sure that the clamping belts are firmly attached to the shielding gas cylinder (the belts must be tight)!
- Do not attach anything to the shielding gas cylinder valve!

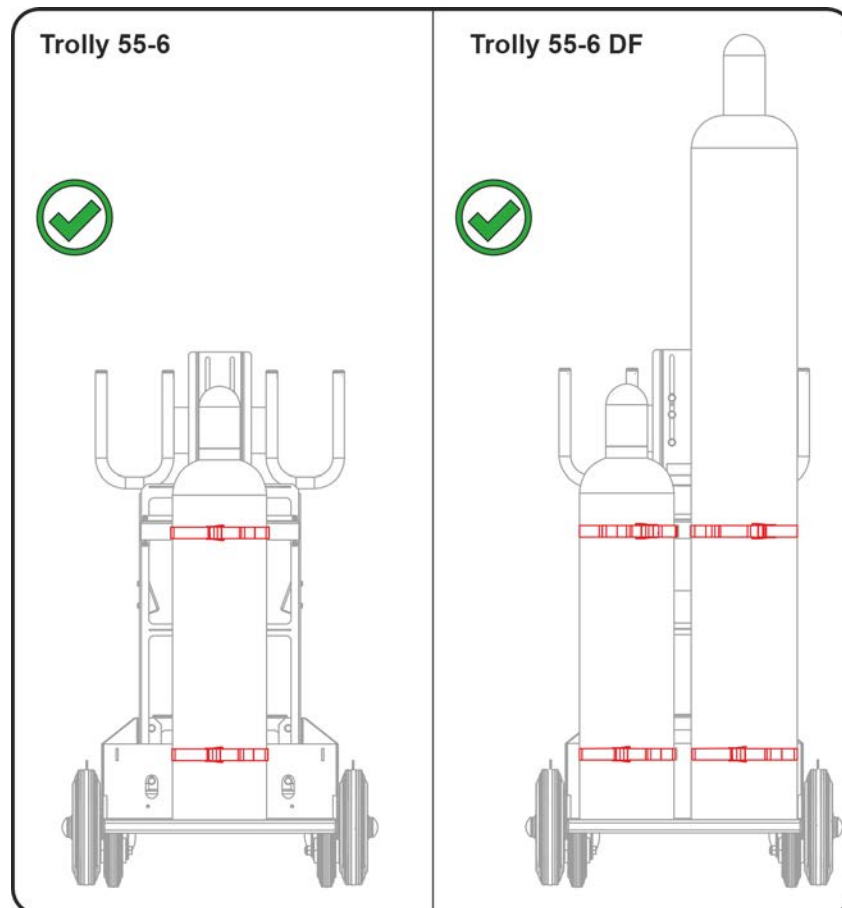

Figure 5-7

- Attaching the clamping belt to secure the shielding gas cylinder > see 5.3.1 chapter.
- Open the tension closures on the clamping belts.
- Place the shielding gas cylinder in the holder provided.
- Secure the shielding gas cylinder with the clamping belts (ensure that they are firm and tight).

5.3.1 Attach the clamping belt to secure the shielding gas cylinder

The item is part of the machine's delivery content.

5.3.1.1 Trolley 55-6

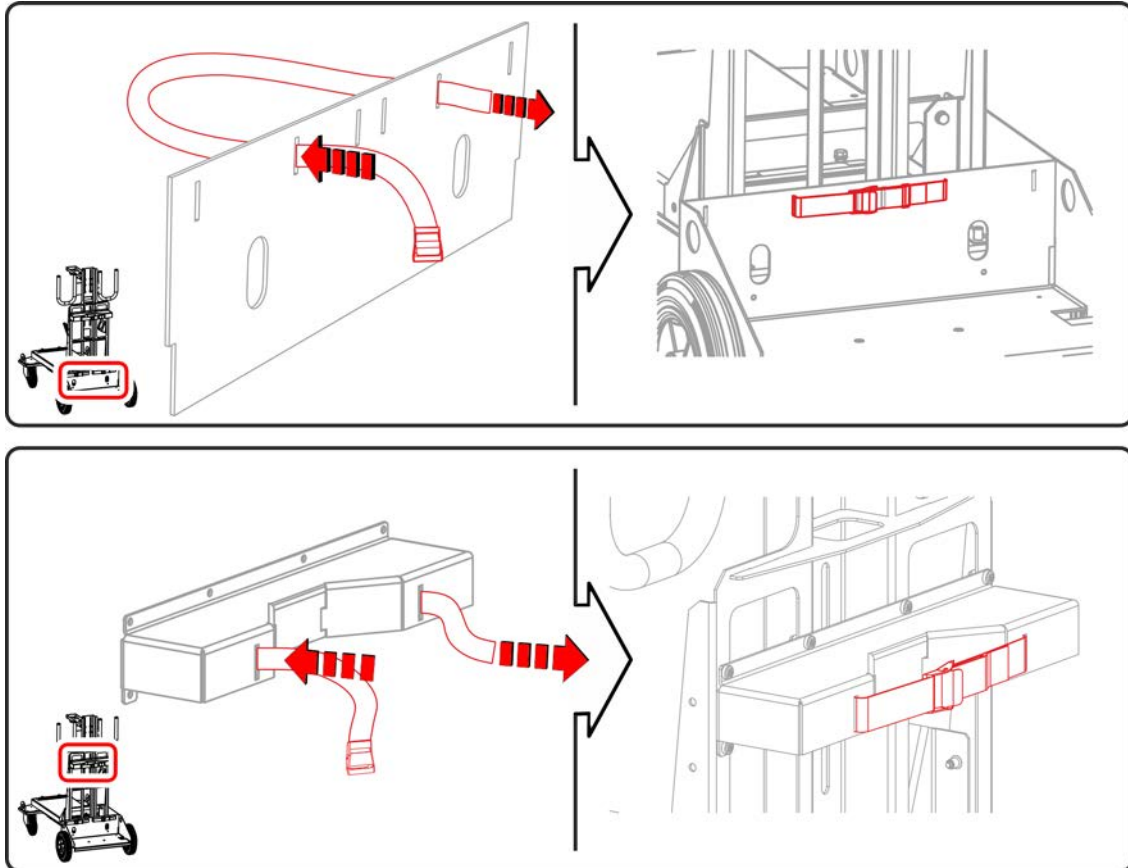

Figure 5-8

- Thread strap as shown.

5.3.1.2 Trolley 55-6 DF

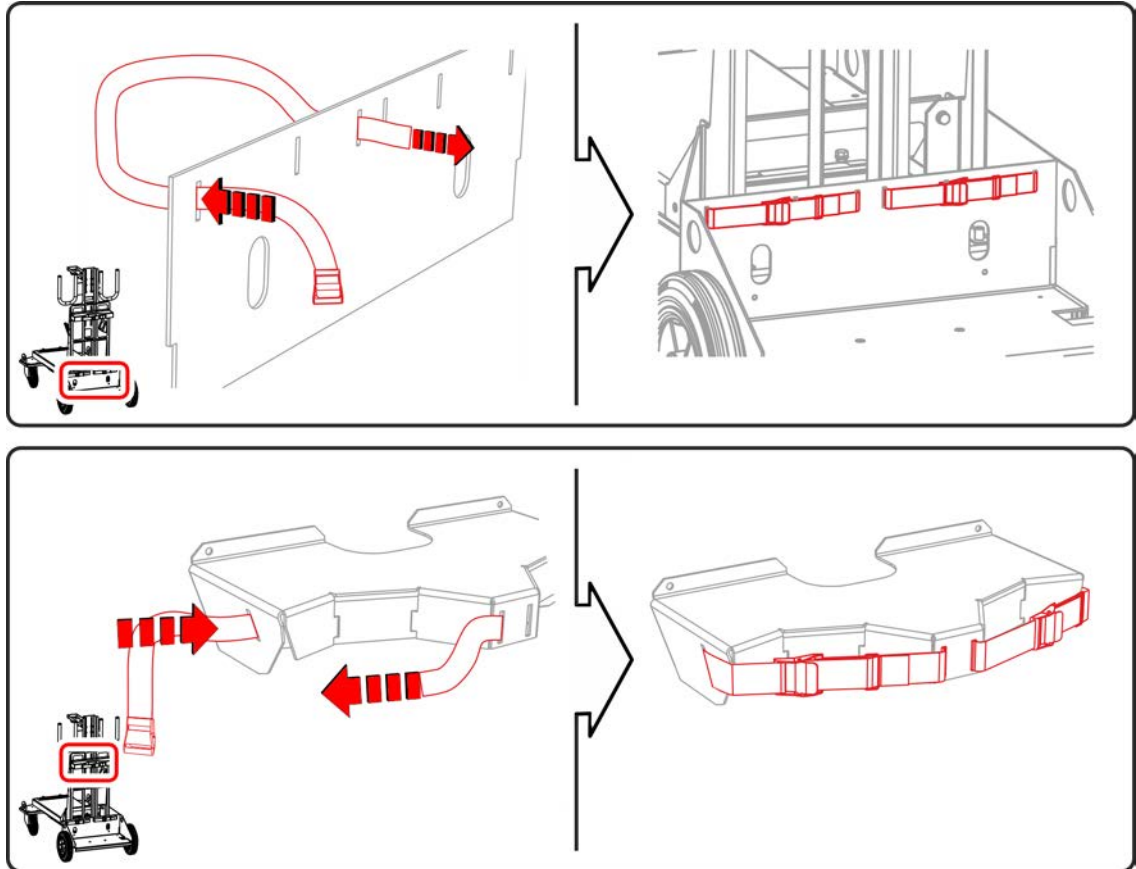

Figure 5-9

- Thread strap as shown.

5.4 Using the transport system

⚠ CAUTION



Improperly fastened machines!

Devices, device combinations and accessories that are not properly fastened to transport systems may tip over during transport and cause injury.

- Use the systems only for transporting the machines specified in > see 3.2 chapter.
- Secure the machines in the middle or at the specified attachment points on the machine carrier.
- Use only the original parts supplied to fasten the machines.
- Check the attachment points before each transport and at regular intervals.



Figure 5-10

5.4.1 Lifting by crane

⚠ WARNING



Risk of injury when lifting by crane!

When lifting the machine by crane, persons may be severely injured by falling machines or mount-on components!

- Remove any supply lines and accessories before lifting by crane (e.g. hose package, wire spool, shielding gas cylinder, toolbox, wire feeder, remote control, etc.)!
- Avoid jerky movements!
- Properly close and lock all casing covers and protective caps before lifting by crane!
- Ensure that the load is distributed evenly! • Use chain hoists and chain slings of the same length only!
- Stay outside the danger zone underneath the machine!
- Use the correct number of hoisting equipment of the right size in the correct position! Observe the crane principle > see 5.4.2 chapter!
- Follow the regulations for occupational safety and accident prevention of the respective country!

⚠ CAUTION



Improperly fastened machines!

Devices, device combinations and accessories that are not properly fastened to transport systems may tip over during transport and cause injury.

- Use the systems only for transporting the machines specified in > see 3.2 chapter.
- Secure the machines in the middle or at the specified attachment points on the machine carrier.
- Use only the original parts supplied to fasten the machines.
- Check the attachment points before each transport and at regular intervals.

5.4.2 Craning principle

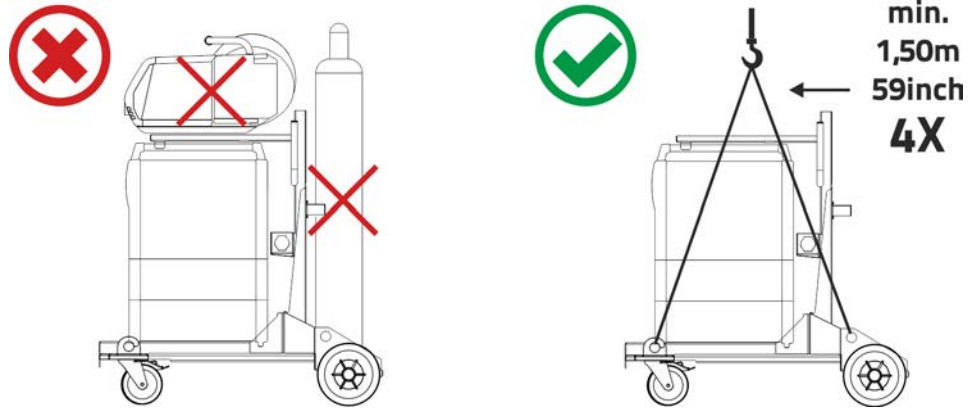

Figure 5-11

6 Maintenance, care and disposal

6.1 General

DANGER



Risk of injury due to electrical voltage after switching off!

Working on an open machine can lead to fatal injuries!

Capacitors are loaded with electrical voltage during operation. Voltage remains present for up to four minutes after the mains plug is removed.

1. Switch off machine.
2. Remove the mains plug.
3. Wait for at least 4 minutes until the capacitors have discharged!

WARNING



Improper maintenance, testing and repairs!

Maintenance, testing and repair of the machine may only be carried out by skilled and qualified personnel (authorised service personnel). A competent person is someone who, based on training, knowledge and experience, can recognize the hazards and possible consequential damage that may occur when testing power sources and can take the necessary safety precautions.

- Follow the maintenance instructions > see 6.2 chapter.
- If any of the test requirements below are not met, the unit must not be put back into operation until it has been repaired and tested again.

Repair and maintenance work may only be performed by qualified authorised personnel; otherwise the right to claim under warranty is void. In all service matters, always consult the dealer who supplied the machine. Return deliveries of defective equipment subject to warranty may only be made through your dealer. When replacing parts, use only original spare parts. When ordering spare parts, please quote the machine type, serial number and item number of the machine, as well as the type designation and item number of the spare part.

Under the specified ambient conditions and normal working conditions this machine is essentially maintenance-free and requires just a minimum of care.

Contamination of the machine may impair service life and duty cycle. The cleaning intervals depend on the ambient conditions and the resulting contamination of the machine. The minimum interval is every six months.

6.1.1 Cleaning

- Clean the outer surfaces with a moist cloth (no aggressive cleaning agents).
- Purge the machine venting channel and cooling fins (if present) with oil- and water-free compressed air. Compressed air may overspeed and destroy the machine fans. Never direct the compressed air directly at the machine fans. Mechanically block the fans, if required.
- Check the coolant for contaminants and replace, if necessary.

6.1.2 Dirt filter

When using a dirt filter, the cooling air throughput is reduced and the duty cycle of the machine is reduced as a result. The duty cycle decreases with the increasing contamination of the filter. The dirt filter must be removed at regular intervals and cleaned by blowing out with compressed air (depending on the level of soiling).

6.2 Maintenance work, intervals

6.2.1 Daily maintenance tasks

Visual inspection

- Mains supply lead and its strain relief
- Gas cylinder securing elements
- Check hose package and power connections for exterior damage and replace or have repaired by specialist staff as necessary!
- Gas tubes and their switching equipment (solenoid valve)
- Check that all connections and wearing parts are hand-tight and tighten if necessary.
- Check correct mounting of the wire spool.
- Wheels and their securing elements
- Transport elements (strap, lifting lugs, handle)
- Other, general condition

Functional test

- Operating, message, safety and adjustment devices (Functional test)
- Welding current cables (check that they are fitted correctly and secured)
- Gas tubes and their switching equipment (solenoid valve)
- Gas cylinder securing elements
- Check correct mounting of the wire spool.
- Check that all screw and plug connections and replaceable parts are secured correctly, tighten if necessary.
- Remove any spatter.
- Clean the wire feed rollers on a regular basis (depending on the degree of soiling).

6.2.2 Monthly maintenance tasks

Visual inspection

- Casing damage (front, rear and side walls)
- Wheels and their securing elements
- Transport elements (strap, lifting lugs, handle)
- Check coolant tubes and their connections for impurities

Functional test

- Selector switches, command devices, emergency stop devices, voltage reducing devices, message and control lamps
- Check wire guide elements (wire feed roll holder, wire feed nipple, wire guide tube) for tight fit. Recommendation for replacing the wire feed roll holder (eFeed) after 2000 hours of operation, see replacement parts).
- Check coolant tubes and their connections for impurities
- Check and clean the welding torch. Deposits in the torch can cause short circuits and have a negative impact on the welding result, ultimately causing damage to the torch.

6.2.3 Annual test (inspection and testing during operation)

A periodic test according to IEC 60974-4 "Periodic inspection and test" has to be carried out. In addition to the regulations on testing given here, the relevant local laws and regulations must also be observed.

For more information refer to the "Warranty registration" brochure supplied and our information regarding warranty, maintenance and testing at www.ewm-group.com!

6.3 Disposing of equipment



Proper disposal!

The machine contains valuable raw materials, which should be recycled, and electronic components, which must be disposed of.

- Do not dispose of in household waste!
- Observe the local regulations regarding disposal!
- According to European provisions (Directive 2012/19/EU on Waste of Electrical and Electronic Equipment), used electric and electronic equipment may no longer be placed in unsorted municipal waste. It must be collected separately. The symbol depicting a waste container on wheels indicates that the equipment must be collected separately.
This machine has to be disposed of, or recycled, in accordance with the waste separation systems in use.

According to German law (law governing the distribution, taking back and environmentally correct disposal of electrical and electronic equipment (ElektroG)), used machines are to be placed in a collection system separate from unsorted municipal waste. The public waste management utilities (communities) have created collection points at which used equipment from private households can be disposed of free of charge.

The deletion of personal data is the responsibility of the end user.

Lamps, batteries or accumulators must be removed and disposed of separately before disposing of the device. The type of battery or accumulator and its composition is marked on the top (type CR2032 or SR44). The following EWM products may contain batteries or accumulators:

- Welding helmets
Batteries or accumulators are easy to remove from the LED cassette.
- Device controls
Batteries or accumulators are located on the back of these in corresponding sockets on the circuit board and are easy to remove. The controls can be removed using standard tools.

Information on returning used equipment or collections can be obtained from the respective municipal administration office. Devices can also be returned to EWM sales partners across Europe.

Further information on the topic of the disposal of electrical and electronic equipment can be found on our website at: <https://www.ewm-group.com/de/nachhaltigkeit.html>.

7 Technical data

7.1 Trolley 55-6 / Trolley 55-6 DF

	Trolley 55-6	Trolley 55-6 DF
Shielding gas cylinder support (10 I/20 I/50 I)	max. pressure: 300 bar max. height: 1640 mm (+/-20) max. diameter: 229 mm (+/-1%)	
Dimensions (L x W x H)	1114 x 678 x 1486 mm	
	43.9 x 26.7 x 58.5 inch	
Weight without accessories	approx. 50.4 kg	approx. 50.8 kg
	approx. 111.1 lb	approx. 112 lb

8 Accessories

Performance-dependent accessories like torches, workpiece leads, electrode holders or intermediate hose packages are available from your authorised dealer.

8.1 Options

Type	Designation	Item no.
ON PS Trolley 55-5 / 55-6	Pivot support	092-002712-00000
ON PS Trolley 55-5 / 55-6 drive D200	Pivot support	092-002634-00000
ON TR Trolley 55-5 / 55-6	Cross arm and holder for wire feeder	092-002700-00000
ON Extender	Extension of the cross arm of the trolley to include further modules	092-003507-00000
ON Case	Tool box for mounting to Trolley 55-5/6	092-002899-00000
voltConverter 230/400	Voltage converter	090-008800-00502

9 Appendix**9.1 Searching for a dealer**

Sales & service partners
www.ewm-group.com/en/specialist-dealers



"More than 400 EWM sales partners worldwide"