

POWERTEC® i350S, i420S, i500S

Spare Parts	1
Figure A: POWERTEC® i350S, i420S & i500S Machine Assembly	2
Figure B, C: POWERTEC® i350S, i420S & i500S Inside Machine Assembly	5
Figure D: POWERTEC® i350S i420S & i500S Front Assembly	6
Miscellaneous Items (not shown in figure A, B, C, D).....	6
Electrical Schematic.....	7
CODE: 50445	7
CODE: 50446	8
CODE: 50447	9



Spare Parts

SP50445, SP50446, SP50447 REV00
11/2019

ASSEMBLY PAGE NAME			Machine Assembly	Inside Machine Assembly	Inside Machine Assembly	Front Assembly	Miscellaneous Items	
CODE NO.:	K NO.:	FIGURE NO.:	A	B	C	D	-	
50445	K14183-1	POWERTEC® i350S	1	1	-	1	1	
50446	K14184-1	POWERTEC® i420S	2	-	2	2	2	
50447	K14185-1	POWERTEC® i500S	3	-	3	3	3	

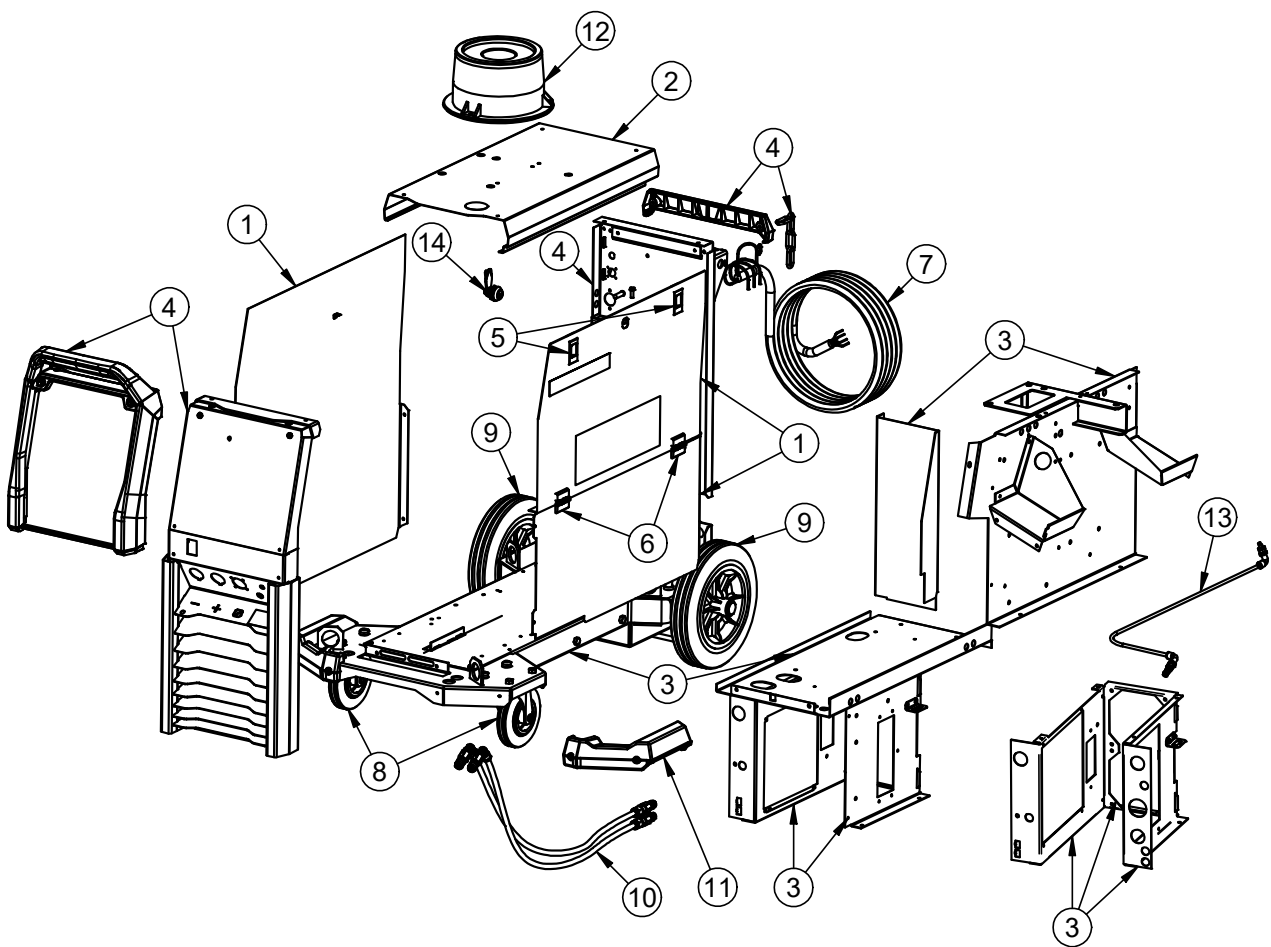

Figure A

Figure A: POWERTEC® i350S, i420S & i500S Machine Assembly

Item	Description	Part Number	QTY	1	2	3	4	5	6	7
1	SIDE PANEL KIT includes:	T-8040-028-1R	1	X	X	X				
	LEFT SIDE PANEL		1	X	X	X				
	UPPER SIDE PANEL		1	X	X	X				
	BOTTOM SIDE PANEL		1	X	X	X				
	LABEL - ROLLS COLOURS		1	X	X	X				
2	COVER KIT includes:	T-8040-029-1R	1	X	X	X				
	SHELF		1	X	X	X				
	WARNING LABEL		1	X	X	X				
3	BASE, PARTITION, SHELF KIT includes:	T-8040-030-1R	1	X						
	BASE ASSEMBLY		1	X						
	PARTITION ASSEMBLY		1	X						
	COVER		1	X						
	SHELF		1	X						
	FUSE LABEL		1	X						
	BRACKET		1	X						
3	BASE, PARTITION, SHELF KIT includes:	T-8040-037-1R	1		X	X				
	BASE ASSEMBLY		1		X	X				
	PARTITION ASSEMBLY		1		X	X				
	COVER		1		X	X				
	SHELF		1		X	X				
	FUSE LABEL		1		X	X				
	BRACKET		1		X	X				
4	FRONT AND REAR PANEL KIT:	T-8040-031-1R	1	X						
	FRONT PANEL ASSEMBLY		1	X						
	REAR PANEL ASSEMBLY		1	X						
	IN LABEL		1	X						
	OUT LABEL		1	X						
	IN/OUT LABEL		1	X						
	GAS LABEL		1	X						
	FRONT HANDLE COMPLETE			X						
	BACK PANEL CASE			X						
	CHAIN		1	X						
4	FRONT AND REAR PANEL KIT:	T-8040-038-1R	1		X	X				
	FRONT PANEL ASSEMBLY				X	X				
	REAR PANEL ASSEMBLY				X	X				
	IN LABEL				X	X				
	OUT LABEL				X	X				
	IN/OUT LABEL				X	X				
	GAS LABEL				X	X				
	FRONT HANDLE COMPLETE				X	X				
	BLACK PANEL CASE				X	X				
	CHAIN				X	X				
5	LOCK	0654-610-004R	2	X	X					
6	LEAF HINGE	0654-610-007R	2	X	X	X				
7	MAIN INPUT CORD	R-5041-497-1R	1	X						
	MAIN INPUT CORD	R-5041-497-2R	1		X	X				
8	WHEELS	1029-660-127R	2	X	X	X				

9	WHEELS	1029-660-250R	2	X	X	X				
10	WATER CONNECTION KIT:	T-8040-032-1R	1	X						
	COOLING HOSES		2	X						
	COUPLING RECTUS		4	X						
	THREAD ADAPTER		4	X						
	ORIENTING ELBOW MALE ADAPTOR		2	X						
	STRAIGHT MALE ADAPTOR		2	X						
10	WATER CONNECTION KIT:	T-8040-034-1R	1		X	X				
	COOLING HOSES		2		X	X				
	COUPLING RECTUS		4		X	X				
	THREAD ADAPTER		4		X	X				
	ORIENTING ELBOW MALE ADAPTOR		2		X	X				
	STRAIGHT MALE ADAPTOR		2		X	X				
11	BUMPER KIT	T-8040-047-1R	2	X	X	X				
12	SWIVEL BRACKET	1361-598-181R	1	X	X	X				
13	GAS CONNECTION KIT:	T-8040-046-1R	1	X	X	X				
	GAS HOSE		1	X	X	X				
	ELBLOW 1/8 WITH SEAL		2	X	X	X				
	BRASS QUICK CONNECTOR		1	X	X	X				
	BRASS QUICK COUPLING		1	X	X	X				
14	KEY LOCK	0654-610-001R	1	X	X	X				

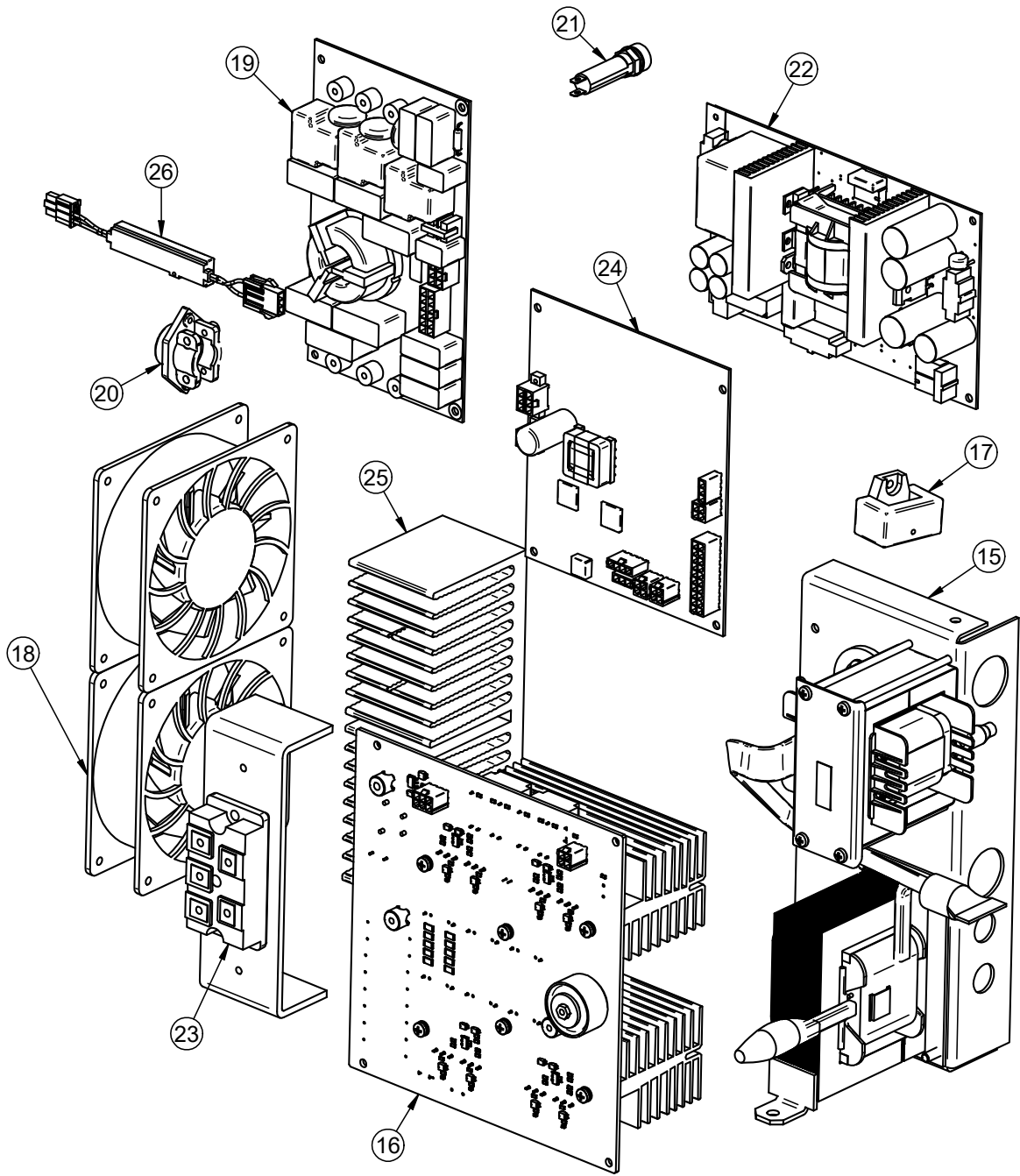

Figure B

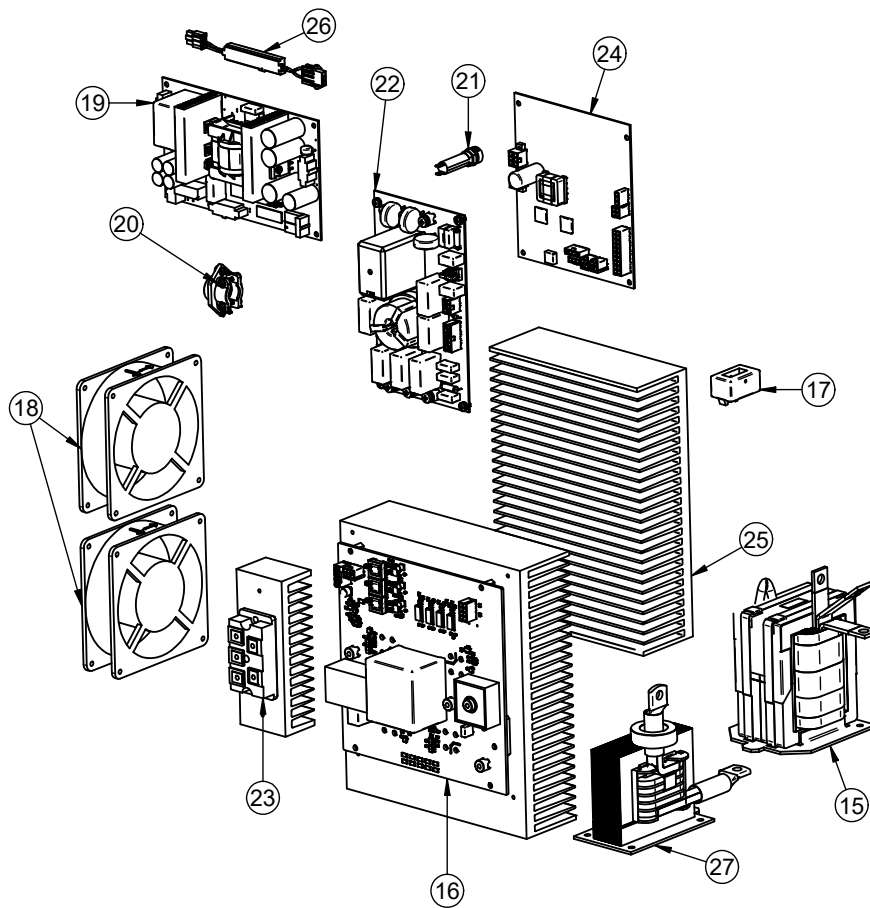

Figure C

Figure B, C: POWERTEC® i350S, i420S & i500S Inside Machine Assembly

Item	Description	Part Number	QTY	1	2	3	4	5	6	7
15	TRANSFORMER AND CHOKE	R-8040-420-1R	1	X						
	TRANSFORMER	R-4034-175-2R	1		X	X				
16	INVERTER BOARD	R-6042-079-1R	1	X						
	INVERTER BOARD	T-8040-022-1R	1		X	X				
17	HALL SENSOR	W4900004R	1	X	X	X				
18	FAN	R-8040-433-1R	2	X						
	FAN	W66X1369R	2		X	X				
19	INPUT FILTER	Y051-1R	1	X						
	INPUT FILTER	Y056-1R	1		X	X				
20	CABLE RELIEF	1361-599-674R	1	X	X	X				
21	FUSE SOCKET	1158-632-032R	1	X	X	X				
	FUSE 2A 400V	1158-660-010R	1	X	X	X				
22	PC BOARD	R-6042-081-1R	1	X	X	X				
23	THREE PHASE BRIDGE	W4100021R	1	X	X	X				
24	CONTROL BOARD	R-6042-091-1R	1	X						
	CONTROL BOARD	R-6042-092-1R	1		X					
	CONTROL BOARD	R-6042-093-1R	1			X				
25	OUTPUT BRIDGE	R-8040-388-1R	1	X						
	HEATSINK KIT	T-8040-023-1R	1		X					
	HEATSINK KIT	T-8040-033-1R	1			X				
26	LED MODULE	R-5041-508-1R	2	X	X	X				
27	CHOKE	R-8040-441-1R	1		X	X				

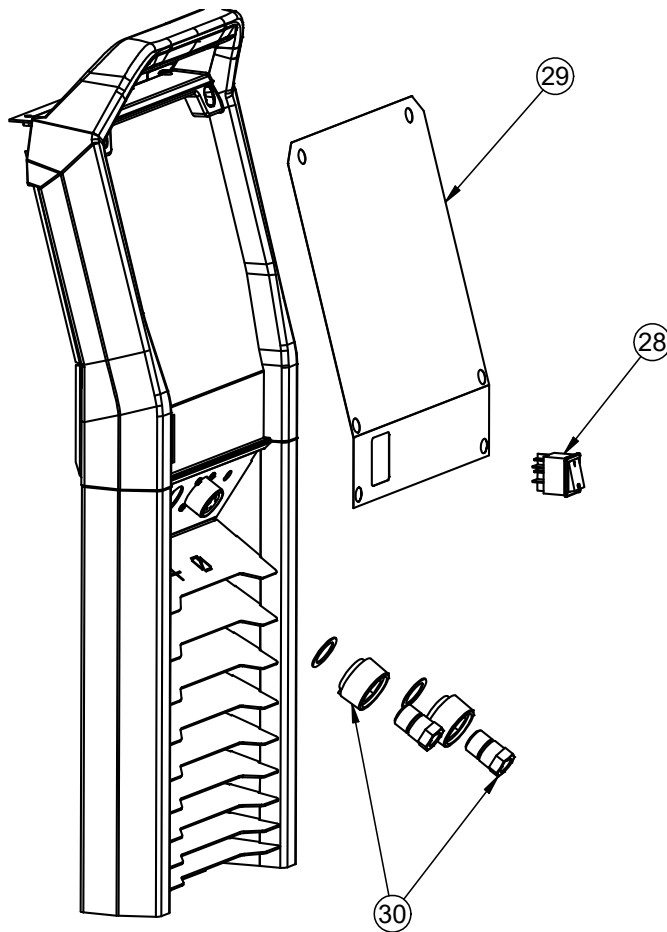

Figure D

Figure D: POWERTEC® i350S i420S & i500S Front Assembly

Item	Description	Part Number	QTY	1	2	3	4	5	6	7
28	MAIN SWITCH	1115-270-022R	1	X	X	X				
29	FRONT LABEL	R-0000-079-1R	1	X						
	FRONT LABEL	R-0000-080-1R	1		X					
	FRONT LABEL	R-0000-081-1R	1			X				
30	SOCKET	2EINN0500FR	2	X						
	SOCKET	90000595PR	2		X	X				

Miscellaneous Items (not shown in figure A, B, C, D)

Item	Description	Part Number	QTY	1	2	3	4	5	6	7
31	HARNESSES KIT	T-8040-035-1R	1	X						
32	HARNESSES KIT	T-8040-036-1R	1		X	X				

Electrical Schematic

CODE: 50445

