

# MagHold™ Extendable Arm & Snake Magnets

*Time saving magnetic tools for use in the shop & in the field.*

## MagHold™ EXTENDABLE ARM

Position and hold steel stock in welding and fabrication.

- Telescoping mounting bar adjusts from 6.4" to 9.3" in length.
- Loosen the center joint in the mounting bar to "fold up" the MagHold™ for different workholding configurations.
- Adjustable magnetic V-Pads at each end hold stock of different shapes: round, flat, angled.

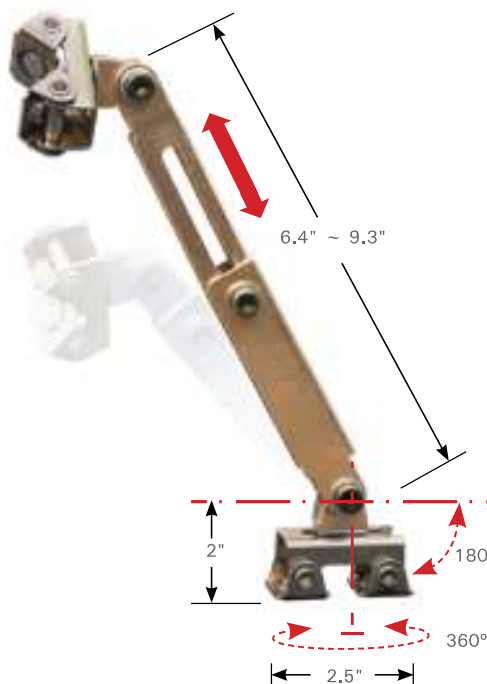

Part No.	Max. Pull Force (lb)	Weight (lb)
MHF608	18	1.3

**⚠ Must be used for tack welding only and removed before completing weld. Avoid prolonged exposure of magnetic products to heat sources of 176°F / 80°C.**

## SNAKE MAGNETS

The Third Hand - Holds, Bends, Twists

The Snake Magnet gives you the flexibility to hold stock at odd angles. Spring Clamp can be used as the third hand to hold tools.



Part No.	Description	Weight (lb)
MFC312	12" flex cable, 1 clamp, 2 Adjustable Magnetic V-pads	1.0
MFC318	18" flex cable, 1 clamp, 2 flat Magnetic Pads	1.4

\*Magnetic force is based on 3/8" thick steel.

**⚠ Must be used for tack welding only and removed before completing weld. Avoid prolonged exposure of magnetic products to heat sources of 176°F / 80°C.**