

Master S

400, 500

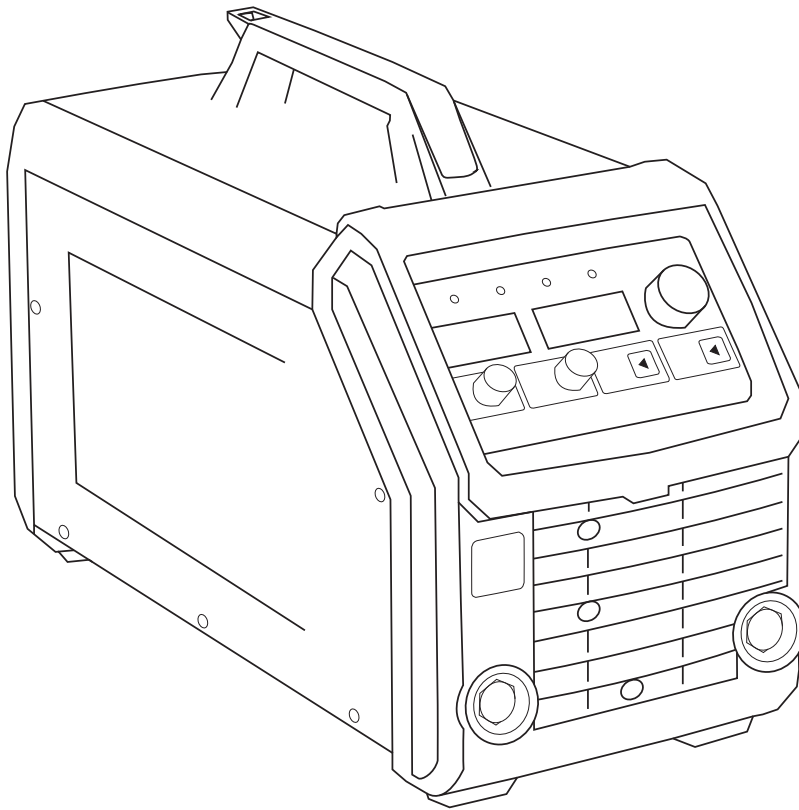

Operating manual **EN**

Bruksanvisning **DA**

Gebrauchsanweisung **DE**

Manual de instrucciones **ES**

Käyttöohje **FI**

Manuel d'utilisation **FR**

Manuale d'uso **IT**

Gebruiksaanwijzing **NL**

Brugsanvisning **NO**

Instrukcja obsługi **PL**

Manual de utilização **PT**

Инструкции по эксплуатации **RU**

Bruksanvisning **SV**

操作手册 **ZH**

OPERATING MANUAL

English

CONTENTS

| | | |
|-------|--------------------------------------------|----|
| 1. | Introduction | 3 |
| 1.1 | General | 3 |
| 1.2 | Product introduction | 3 |
| 1.3 | Machine introduction | 4 |
| 2. | Installation | 5 |
| 2.1 | Before use | 5 |
| 2.2 | Positioning of the machine | 5 |
| 2.3 | Distribution network | 5 |
| 2.4 | Welding and earth return cable connections | 6 |
| 2.4.1 | Choosing welding polarity in MMA welding | 6 |
| 2.4.2 | Choosing welding polarity in TIG welding | 6 |
| 2.4.3 | Earthing | 6 |
| 3. | Operation | 6 |
| 3.1 | Welding processes | 6 |
| 3.1.1 | MMA welding | 6 |
| 3.1.2 | TIG welding | 6 |
| 3.2 | Operation functions | 7 |
| 3.2.1 | Power source | 7 |
| 3.2.2 | Control panel and SETUP functions | 7 |
| 3.2.3 | Activation and setup parameter adjustment | 8 |
| 3.3 | MMA welding | 9 |
| 3.3.1 | Filler materials and equipment | 9 |
| 3.3.2 | Earth return cable and clamp | 9 |
| 3.3.3 | Manual metal arc welding (MMA) | 9 |
| 3.3.4 | Electrode welding parameter table | 10 |
| 3.3.5 | Arc force | 10 |
| 3.3.6 | Hot start | 10 |
| 3.4 | TIG welding | 11 |
| 3.5 | Carbon arc gouging | 12 |
| 3.6 | Wireless remote | 12 |
| 4. | Maintenance | 13 |
| 4.1 | Regular maintenance | 13 |
| 4.1.1 | Every six months | 13 |
| 4.2 | Service contract | 13 |
| 4.3 | Storage | 13 |
| 4.4 | Disposal of the machine | 13 |
| 5. | Troubleshooting | 14 |
| 5.1 | Troubleshooting | 14 |
| 5.2 | Control panel error codes | 15 |
| 6. | Ordering codes | 16 |
| 7. | Technical data | 16 |

1. INTRODUCTION

1.1 General

Congratulations on choosing the Master S series power source. Used correctly, Kemppi products can significantly increase the productivity of your welding, and provide years of economical service.

This operating manual contains important information on the use, maintenance and safety of your Kemppi product. The technical specifications of the device can be found at the end of the manual.

Please read the operating manual and the safety instructions booklet carefully before using the equipment for the first time. For your own safety and that of your working environment, pay particular attention to the safety instructions.

For more information on Kemppi products, contact Kemppi Oy, consult an authorised Kemppi dealer, or visit the Kemppi web site at www.kemppi.com.

The specifications presented in this manual are subject to change without prior notice.

Important notes

Items in the manual that require particular attention in order to minimise damage and personal harm are indicated with the 'NOTE!' notation. Read these sections carefully and follow their instructions.

Disclaimer

While every effort has been made to ensure that the information contained in this guide is accurate and complete, no liability can be accepted for any errors or omissions. Kemppi reserves the right to change the specification of the product described at any time without prior notice. Do not copy, record, reproduce or transmit the contents of this guide without prior permission from Kemppi.

1.2 Product introduction

Master S model welding machines are designed for industrial use and for welding all kinds of covered electrodes. Master S is also suitable for carbon arc gouging.

In addition to the basic functions Master S 400 and 500 models include advanced functions like HotStart, ArcForce, TIG mode and remote control, which are all set through the panel.

Both models come equipped with a voltage reduction device (VRD) that is designed to maintain the open-circuit voltage (OCV) below 35 volts.

Master S 400 and 500 models can also operate in constant voltage (CV) mode as a parent power supply for Kemppi voltage sensing wire feed systems and in-line TIG solutions – such as ArcFeed and MasterTig LT 250.

Master S 400 Cel and 500 Cel models are available for cellulose welding.

1.3 Machine introduction

Master S 400 and 500

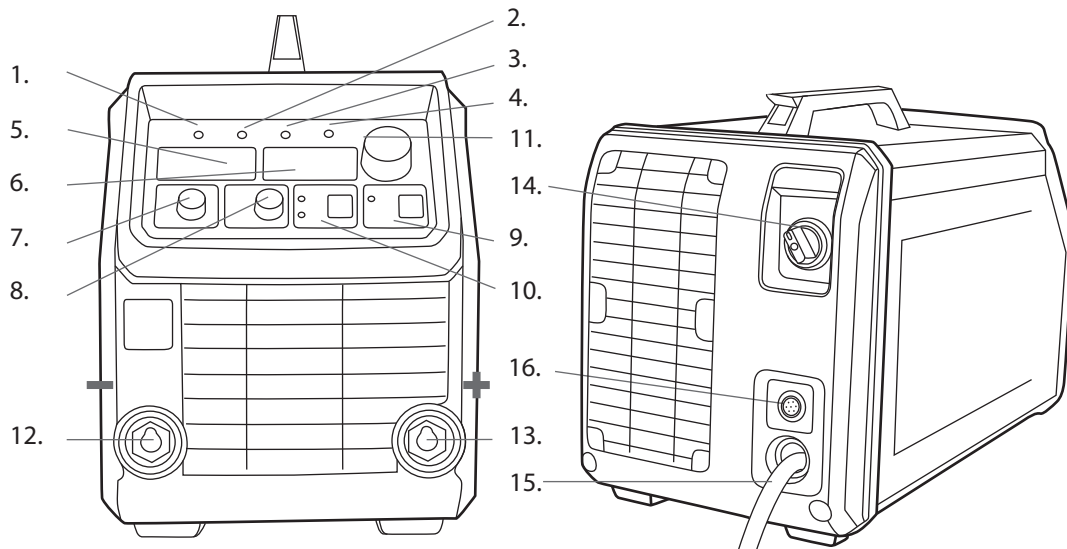

1. Power on pilot lamp
2. Overheating pilot lamp
3. CV mode pilot lamp
4. VRD ON pilot lamp
5. Amperage meter display
6. Voltage meter display
7. ArcForce
8. HotStart
9. Remote Control
10. Welding Mode
11. Welding current adjustment knob
12. Negative (-) pole connection socket
13. Positive (+) pole connection socket
14. Main switch (ON/OFF)
15. Mains power cable
16. Remote control connector

Display cover comes standard with Master S 400 and 500. It protects the panel from sparks, dust and scratches.

2. INSTALLATION

2.1 Before use

The product is packed in cartons designed specifically for them. However, always make sure before use that the products have not been damaged during transportation.

Check also that you have received the components you ordered and the instruction manuals needed. Product packaging material is recyclable.

NOTE! When moving the welding machine, always lift it from the handle, never pull it from the welding or other cables.

Operating environment

This machine is suitable for both indoor and outdoor use. Always make sure that the air flow in the machine is unrestricted. The recommended operating temperature range is $-20\dots+50$ °C.

Please read also the Safety Instructions concerning the operating environment.

2.2 Positioning of the machine

Place the machine on a sturdy, level surface that is dry and does not allow dust or other impurities to enter the machines cooling air flow. Preferably site the machine to a suitable carriage unit so it is above floor level.

Notes for positioning the machine

- The surface inclination may not exceed 15 degrees.

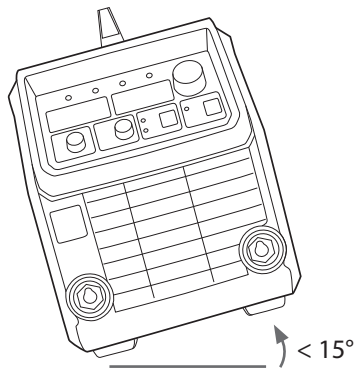

- Ensure the free circulation of the cooling air. There must be at least 20 cm of free space in front of and behind the machine for cooling air circulation.
- Protect the machine against heavy rain and direct sunshine.

The machine is not allowed to be operated in the rain as the protection class of the machine, IP23S, allows preserving and storing outside only.

NOTE! Never aim the spray of sparks from a grinding machine toward the equipment.

2.3 Distribution network

All regular electrical devices without special circuits generate harmonic currents into distribution network. High rates of harmonic current may cause losses and disturbance to some equipment.

This equipment complies with IEC 61000-3-12 provided that the short-circuit power S_{sc} is greater than or equal to 4.0 MVA at the interface point between the user's supply and the public supply network. It is the responsibility of the installer or user of the equipment to ensure, by consultation with the distribution network operator if necessary, that the equipment is connected only to a supply with a short-circuit power S_{sc} greater than or equal to 4.0 MVA.

2.4 Welding and earth return cable connections

2.4.1 Choosing welding polarity in MMA welding

You can change the welding polarity by choosing (+) or (-) cable connector. Typically, in MMA welding, the welding cable is connected to the positive (+) pole connection socket and the earth return cable to the negative (-) pole connection socket.

2.4.2 Choosing welding polarity in TIG welding

In TIG welding the welding cable must be connected to the negative (-) pole connection socket and the earth return cable to the positive (+) pole connection socket.

2.4.3 Earthing

If possible, always fasten the clamp of the earth return cable directly onto work piece.

1. Clean contact surface of the clamp from paint and rust.
2. Fasten the clamp properly, so that contact surface is as large as possible.
3. Check that the clamp is fastened firmly.

EN

3. OPERATION

NOTE! *Welding in places presenting an immediate fire or explosion hazard is forbidden! Welding fumes may cause injury, take care of sufficient ventilation during welding!*

3.1 Welding processes

3.1.1 MMA welding

MMA welding, as well as carbon arc gouging, is possible with Master S power sources. Separate models including cellulose welding characteristic are also available. See 'Ordering codes'.

3.1.2 TIG welding

For TIG welding a separate TIG-torch with gas valve is required. See 'Ordering codes'.

3.2 Operation functions

3.2.1 Power source

NOTE! Always switch the machine on and off from main switch. Do not use the mains plug for switching!

NOTE! Never watch the arc without a proper face shield designed for arc welding! Protect yourself and the surroundings against welding arc and hot spatters!

3.2.2 Control panel and SETUP functions

WeldData

After welding has finished, the display shows the measured average current of the last weld. This weld data is only displayed if the welding cycle lasts for 5 seconds or more.

Advanced control panel

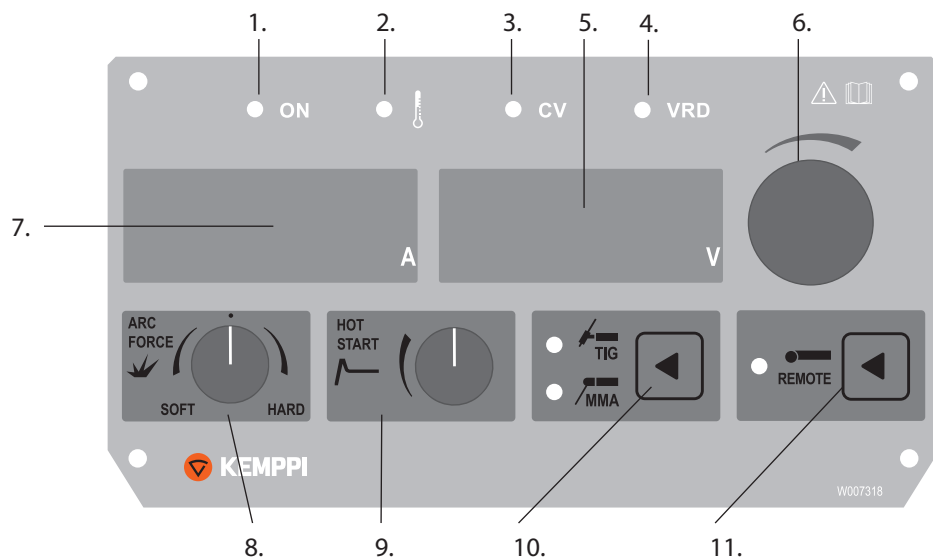

1. The green ON light indicates that the power source is turned on.
2. Overheating indicator. Light indicates that the machine is overheated.
3. CV mode indicator. Light indicates that machine is in CV mode. Mode can be changed from Setup.
4. VRD indicator. Light indicates that VRD is set on.
 - Solid green light: VRD is used, OCV is under 35 V.
 - Flashing red light: VRD is used, OCV is over 35 V.
5. Voltage meter display. Shows voltage.
6. Welding current adjustment knob. Turn the knob to set the welding current value.
7. Amperage meter display. Shows used current value during welding and the set current value when not welding.
8. ArcForce. The smaller the value, the softer the arc. When using a bigger value, the harder the arc gets. Adjustment range is -9...9. The value is shown on the right display when the control knob is turned. Factory setting is 0 (control knob set pointing up).
9. HotStart. Adjust to value 0 = no HotStart, adjust to 10 = HotStartMax. The value is shown on the right display when the control knob is turned. Factory setting is 5 (control knob set pointing up).
10. Welding Mode. Press to select TIG or MMA mode. Light indicates the selection.
11. Remote Control. Press to select remote or panel control. Light indicates remote control.
 - Long press (> 3 s) activates setup function.

3.2.3 Activation and setup parameter adjustment

1. Press remote selection button (11) for at least 3 seconds, until the text "Set" appears on the screen.
2. Choose the needed parameter with the welding current adjustment knob (6).
3. To select the required parameter, press the remote selection button (11). You can move from adjustment mode to selection mode with a new press of the button (11).
4. Use the Welding current adjustment knob (6) to adjust the parameter value.
5. You can exit Setup mode with a long press of remote selection button (11). Setup parameters are saved when you exit Setup.

Setup menu structure

| Advanced control panel | | | | |
|------------------------|---------------------------|--------------------------------------------------------------------------------------------------------------------------------|--------------------------|------------------|
| Name | Function | Description | Factory default | Adjustment range |
| Ant. | Antifreeze | If Antifreeze selection is On, the machine cuts off the power and protects the electrode if sticking occurs during the welding | On | On/OFF |
| Cab. | Long cables | Long cable mode for welding circuits of 50 m and longer (max. 80 m) | OFF | On/OFF |
| Gen. | Generator | Generator mode for generator use and fluctuating mains networks | OFF | On/OFF |
| CU | CV mode | CV mode selection | OFF | On/OFF |
| rc | Remote selection | Remote operation mode. Selection between analog and wireless remote controllers (R10/R11T) | r10 | r10/r11 |
| rcL | Remote low current limit | Limits the remote adjustment range. Allows more exact remote adjustment. | 30 | 30-MAX |
| rcH | Remote high current limit | Limits the remote adjustment range. Allows more exact remote adjustment. | MAX | 30-MAX |
| Urd | VRD selection | Reduces open circuit voltage below 35V | OFF (device specific) | On/OFF |
| Fac. | Restore factory settings | Restores setup and panel settings to factory default | OFF | rES/OFF |

Constant Voltage (CV)

In CV mode the welding machine maintains a relatively stable, consistent voltage regardless of the amperage. This mode is recommended to be used with carbon arc gouging and in MIG/MAG welding with Kemppi voltage sensing wire feed systems. CV mode is activated through the setup menu.

Voltage Reduction Device (VRD)

Master S 400 and 500 contain a voltage reduction device (VRD), which reduces the open-circuit voltage below 35 V. This reduces the risk of electric shock in particularly dangerous environments, such as closed or damp spaces. VRD is activated through the setup menu.

3.3 MMA welding

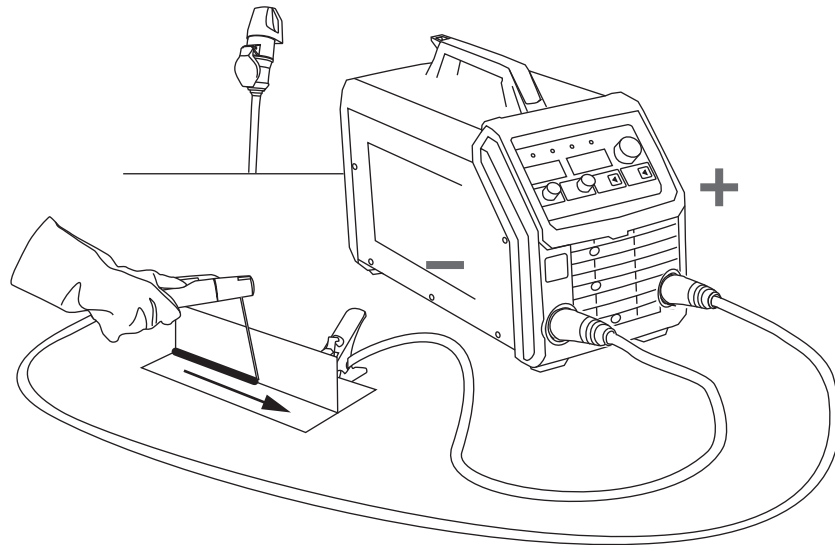

In manual metal arc welding (MMA), the filler material is melted from the electrode to the weld pool. The rate of welding current is selected on the basis of the electrode size and welding position. The arc forms between the electrode tip and work piece. The melting electrode coating forms a gas and slag shield, which protects the molten metal in transfer to the weld pool and during solidification. As the slag solidifies over the hot weld metal, it prevents weld metal from oxidation. This slag coating is removed after welding e.g. with a chipping hammer. When removing the slag coating, ensure you protect your eyes and face with suitable equipment.

For more info, visit www.kemppi.com > Welding ABC.

3.3.1 Filler materials and equipment

Master S series can be used with most of the common electrode types for DC welding. For welding with cellulosic electrodes, the optional kit should be fitted. Electrode sizes for the unit are listed in Technical data section later in this manual. Follow the welding specifications given on the electrode package.

1. Check that the welding cable and earth return cable connections are hand tight. If a cable connection is loose, it will result in a decrease of welding performance, overheating of the connection, and it may affect your product warranty cover.
2. Select and mount the correct electrode type firmly in holder.

3.3.2 Earth return cable and clamp

If possible, always fix the earth return cable and clamp directly to the welding work piece.

1. Clean the connection surface of the clamp from paint, dirt and rust.
2. Connect the clamp carefully so that contact surface is as large as possible.
3. Finally check that the clamp remains fastened.

3.3.3 Manual metal arc welding (MMA)

Select your required welding parameters according to the manufacturer's filler material recommendations and the joint to be welded.

1. Select the required polarity (+ or -) of welding current cable (normally +) and earth return cable (normally -) according to the filler material manufacturers recommendations.
2. Select MMA welding mode by pressing the process selection button on the control panel.
3. Select a suitable welding current by adjusting the current adjustment knob.
4. Make a small test weld to check the selections made.

Site your equipment in a suitable location, ensuring there is adequate cable length to complete the weld pass. Before you start welding, ensure you are comfortably positioned in front of the work piece, and that you are well balanced with your weight equally distributed. Ensure that the power source current setting is correct for the electrode size selected. Draw the welding face shield over your eyes. (Electronic welding face shields like Kemppi Beta 90X allow you to see the welding start point more accurately and better concentrate on the welding process. This reduces the possibility of arc flash.)

NOTE! Ensure that others in the welding area are aware that you're going to weld.

To establish the arc, scratch the electrode on the surface of the work piece.

As the arc starts, move the welding electrode at a pulling angle. The boundary of the slag formed is visible after the molten weld. It must be behind the molten weld. The distance of the slag boundary from the molten weld can be adjusted with the welding current and the angle of the electrode. Throughout the welding, concentrate on the length of the arc and keep it as short as possible. The length of the arc increases easily as the electrode decreases in length during the welding. End welding by moving the welding electrode slightly back to the completed weld and then lifting the electrode straight away from the work piece.

Your completed weld bead should be straight and of even width and bead height, consistent in its appearance. Travel too slowly during welding and the weld pool will get too big and may burn through the weld piece, too fast and the resulting weld will be too small and may have slag entrapments and/or poor strength. After welding, the solidified slag on the weld surface should easily remove with a chipping hammer. Ensure you wear eye and face protection when removing the slag from the weld surface.

3.3.4 Electrode welding parameter table

| Electrode diameter (mm) | Rutile E6013 (A) | Basic E7018 (A) |
|-------------------------|------------------|-----------------|
| 1.6 | 30–60 | 30–55 |
| 2.0 | 50–70 | 50–80 |
| 2.5 | 60–100 | 80–110 |
| 3.25 | 80–150 | 90–140 |
| 4.0 | 100–200 | 125–210 |
| 5.0 | 150–290 | 200–260 |
| 6.0 | 200–385 | 220–340 |
| 7.0 | | 280–410 |

3.3.5 Arc force

Adjusting arc force by turning the ArcForce knob will affect the roughness of the arc. Factory setting for all electrode types is zero. If the value is set to -9...-1 the arc is softened and the amount of spatter decreases when welding at the upper end of the recommended current range of the electrode. If the value is set to 1...9 the arc gets rougher.

The value is shown on the right display during the adjustment.

3.3.6 Hot start

HotStart increases the current for the arc ignition momentarily. With very thin work pieces hot start is generally not needed (depends on the electrode type).

The hot start value is selected between 0 and 10. Zero shuts HotStart off (no HotStart) and 10 sets it to HotStartMax. Factory setting is 5.

The value is shown on the right display during the adjustment.

3.4 TIG welding

NOTE! In TIG welding the welding cable must be connected to the negative (-) pole connection socket and the earth return cable to the positive (+) pole connection socket.

Select your required welding parameters according to the manufacturer's filler material recommendations and the joint to be welded.

1. Select the required polarity of welding current cable (-) and earth return cable (+) for TIG welding.
2. Select TIG welding mode by pressing the process selection button on the control panel.
3. Select a suitable welding current by adjusting the current adjustment knob.
4. Make a small test weld to check the selections made.

Shielding gas is used in DC TIG welding. Your dealer will give you advice on choosing gas and equipment.

You can start welding after having made the necessary selections. Open the gas valve on the TTM 15 V BC. When gas starts to flow, arc is lit by lightly scratching work piece with the tip of the tungsten electrode, or with the touch and lift method (see 'Ignition by Lift TIG'). When arc is lit, its length is regulated by holding the tip of the tungsten electrode at a suitable distance from the work piece. Suitable arc length is usually about half the diameter of the electrode core wire. Move the torch forwards from the starting point. If necessary, adjust current value.

The filler material, tungsten electrode and the welding current level are decided according to the base material type and thickness, joint form and welding position.

Stop welding by lifting the torch off the welding piece and by closing the gas valve on the torch.

NOTE! The torch voltage will remain on.

NOTE! Always fix the gas cylinder so that it stays steadily in upright position either in specially made wall rack or cylinder trolley. Always close the cylinder valve after having finished welding.

Ignition by Lift TIG

You can ignite TIG arc with the Lift TIG method. Gently touch the work piece with the electrode and quickly lift the electrode from the work piece to a suitable welding distance to ignite the arc. If electrode contact with the work piece exceeds 1 second, the power source ignition will automatically shut off preventing damage to the electrode.

To stop welding, quickly pull the electrode away from the work piece.

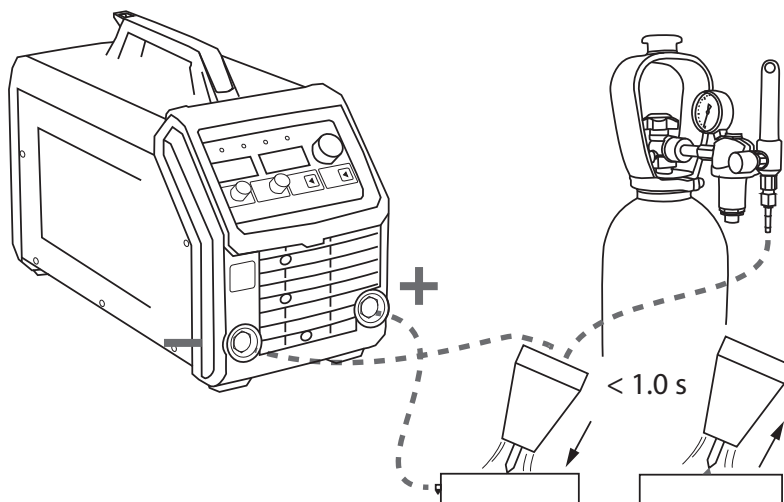

Order information for the additional equipment (TIG torch) required for TIG welding can be found in 'Ordering codes' section later in this manual.

3.5 Carbon arc gouging

Constant voltage (CV) mode is recommended to be used with carbon arc gouging. In CV mode the voltage is adjusted. Gouging is also possible in MMA mode. Refer to the table below for voltage and amperage settings.

| Electrode | Voltage (V) / CV Mode | Amperage (A) / MMA mode |
|----------------|-----------------------|-------------------------|
| 6.35 mm (1/4") | 36–45 V | 170–330 A |
| 8 mm (5/16") | 39–45 V | 230–450 A |
| 9.5 mm (3/8") | 43–45 V | 300–500 A |

3.6 Wireless remote

In addition to the analog remote control unit, Master S also supports wireless remote. Wireless remote is activated by selecting remote operation mode with the 'Remote' button in the panel and then choosing 'r11' (wireless remote control R11T) through the panel's setup function.

VRD mode must be switched off. Wireless remote doesn't function when VRD is on.

Using wireless remote:

1. Set the desired welding current with the adjustment knob in the remote.
2. Touch the work piece with the remote tip and at the same time touch the remote's contact surface with the electrode.

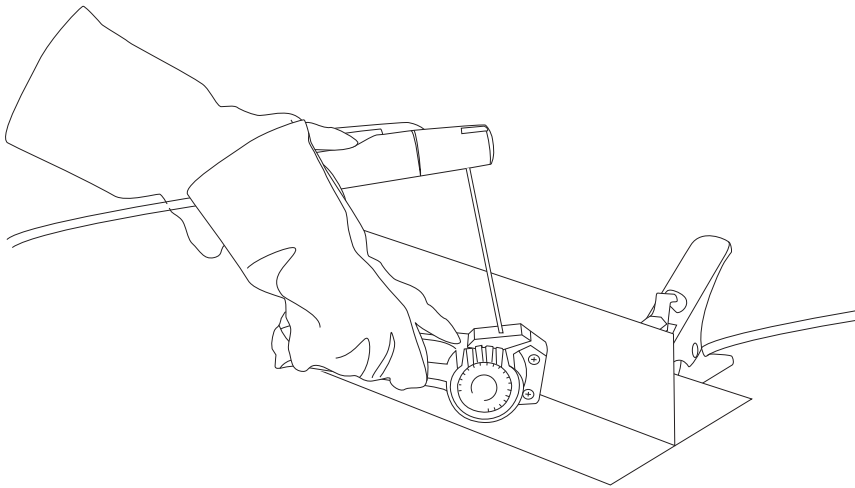

4. MAINTENANCE

NOTE! Watch out for mains voltage when handling electric cables!

Degree and circumstances of machine utilisation should be taken into consideration when planning product maintenance. Careful use and preventive maintenance helps to avoid unnecessary production disturbances and breaks. Check the condition of the welding and connection cables daily. Do not use damaged cables.

4.1 Regular maintenance

4.1.1 Every six months

NOTE! Disconnect the plug of the machine from the mains socket and wait for about 2 minutes before removing the casing plate.

The following maintenance operations should be carried out at least every six months:

- Electric connections of the machine – clean any oxidised parts and tighten any loose ones.

NOTE! You must know the correct tension torques before you start repairing the connections.

- Clean the inner parts of the machine from dust and dirt e.g. with a soft brush and a vacuum cleaner. Do not use compressed air because there is the danger that the dirt is packed even more tightly in the gaps of the cooling profiles. Do not use a pressure washer.

NOTE! Only an authorised electrician may repair the machine.

NOTE! The machine and control panel are at mains current potential. DO NOT remove either the cover or control panel unless authorised to do so. Only authorised and trained personnel can carry out maintenance and repair processes.

4.2 Service contract

Kemppi service workshops make special service contracts with customers about regular maintenance. All parts are cleaned, checked and if necessary, repaired. Also the operation of welding machine is tested.

4.3 Storage

The machine must be stored in a clean and dry room. Protect the machine from rain and direct sunshine in places where temperature exceeds +25 °C.

4.4 Disposal of the machine



Do not dispose of electrical equipment with normal waste!

Electrical equipment that has reached the end of its life must be collected separately and taken to an appropriate environmentally responsible recycling facility.

The owner of the equipment is obliged to deliver a decommissioned unit to a regional collection centre, as per the instructions of local authorities or a Kemppi representative. By applying this you will improve the environment and human health.

5. TROUBLESHOOTING

The control panel will display any errors of the system. Error code numbers are shown in the display and can be compared to the table below.

5.1 Troubleshooting

Power On light is not illuminated.

There is no electrical power to the machine.

- Check the mains electrical supply is connected.
- Check the mains fuses, replace blown fuses.
- Check the mains cable and plug, replace defect parts.

The machine is not welding properly. Welding creates spatter. The weld joint is porous or power supply is insufficient.

- Check the welding parameter settings and adjust if needed. See welding parameter table on page 10.
- Check that the earth return clamp is properly fastened and that earth return cable has no defects. If necessary change the clamp location and replace defective parts.
- Check the welding cable and connector. Tighten the connection(s) and replace defective parts.

Power source overheating pilot lamp is illuminated.

Power source has exceeded the designed working temperature. Fans are running and the machine is in a cooling down cycle. The machine will reset automatically.

- Check that there is enough free space around the machine for cooling air circulation.
- In some cases when error occurs, the machine turns off. Then user must turn the main switch off and on again.
- Check that welding circuit is open.

5.2 Control panel error codes

| | | |
|-----------------------|-------------------------------------------------------------------------------------------------------------------------------------------------------|-------------------------------------------------------------------------------------------------|
| Error 1 (E1) | Power source is not calibrated. | Calibrate power source. |
| Error 2 (E2) | Undervoltage | Check the mains network connection and fuses. |
| Error 3 (E3) | Overvoltage | Check the mains network connection and fuses. |
| Error 4 (E4) | Overheating. Also the overheating pilot lamp is on. Machine drops welding current for 30s. If error conditions still apply: Machine stops welding. | Ensure free air flow. Let the machine cool down. |
| Error 5 (E5) | --- | |
| Error 6 (E6) | --- | |
| Error 7 (E7) | NTC warning. (IGBT overheating). Machine drops welding current. | Ensure free air flow. Let the machine cool down. Check the environment temperature. |
| Error 8 (E8) | NTC error. (IGBT overheating). If error conditions (Err7) still apply: Machine stops welding (model A) Machine shuts down (model R). | Ensure free air flow. Let the machine cool down. Check the environment temperature. |
| Error 9 (E9) | Mains network phase alarm. | Check the mains network connection and fuses. If connected to generator check setup jumper Gen. |
| Error 10 (E10) | --- | |
| Error 11 (E11) | VRD error. | |
| Error 12 (E12) | Power source is locked. Too long short circuit. Machine stops welding. | Avoid long short circuits (20s). |
| Error 13 (E13) | Wrong panel type. | Check the panel. |
| Error 14 (E14) | Current feedback is missing. | Contact Kemppi service representative. |

6. ORDERING CODES

| | | |
|------------------------------|--------------------------------------------|-----------|
| Master S 400 | | 6321400 |
| Master S 500 | | 6321500 |
| Master S 400 Cel | including cellulose welding characteristic | 632140001 |
| Master S 500 Cel | including cellulose welding characteristic | 632150001 |
| Welding cable | 50 mm ² , 5 m | 6184501H |
| | 70 mm ² , 5 m | 6184701H |
| Earth return cable | 50 mm ² , 5 m | 6184511H |
| | 70 mm ² , 5 m | 6184711H |
| Slide bars | | SP007023 |
| Remote control R10 | 5 m | 6185409 |
| | 10 m | 618540901 |
| Wireless remote control R11T | | 6185442 |
| TTM 15 V BC | 4 m | 627143201 |

7. TECHNICAL DATA

| Master S | | 400 | 500 |
|---------------------------------------------------------|------------|-----------------------------|-----------------------------|
| Connection voltage | 3~50/60 Hz | 380 – 440 V (-10 %...+10 %) | 380 – 440 V (-10 %...+10 %) |
| Rated power at max. current | 60 % ED | 20kVA | 26 kVA |
| Fuse (delayed) | | 25 A | 35 A |
| Output at 40 °C MMA | 60 % ED | 400 A / 36 V | 500 A / 40 V |
| | 100 % ED | 310 A / 32.4 V | 390 A / 35.6 V |
| Output at 40 °C TIG | 60 % ED | 400 A / 26 V | 500 A / 30 V |
| | 100 % ED | 310 A / 22.4 V | 390 A / 25.6 V |
| Max welding voltage | | 400 A / 48 V | 500 A / 46 V |
| Stick electrodes | | ø 1.6...6.0 mm | ø 1.6...7.0 mm |
| Welding current control | | stepless | stepless |
| Power factor at 100 % | | 0.90 | 0.90 |
| Efficiency at 100 % | | 0.89 | 0.89 |
| Degree of protection | | IP23S | IP23S |
| Operating temperature range | | -20...+50 °C | -20...+50 °C |
| EMC class | | A | A |
| Minimum short circuit power S_{sc} of supply network* | | 4.0 MVA | 4.0 MVA |
| R_{SCE} | | 214 | 235 |
| External dimensions | L x W x H | 570 x 270 x 370 mm | 570 x 270 x 370 mm |
| Weight | | 20.5 kg | 23.5 kg |

*) See paragraph 2.3.

KEMPPI OY

Kempinkatu 1
PL 13
FIN-15801 LAHTI
FINLAND
Tel +358 3 899 11
Telefax +358 3 899 428
export@kemppi.com
www.kemppi.com

Kotimaan myynti:

Tel +358 3 899 11
Telefax +358 3 734 8398
myynti.fi@kemppi.com

KEMPPI SVERIGE AB

Box 717
S-194 27 UPPLANDS VÄSBY
SVERIGE
Tel +46 8 590 783 00
Telefax +46 8 590 823 94
sales.se@kemppi.com

KEMPPI NORGE A/S

Postboks 2151, Postterminalen
N-3103 TØNSBERG
NORGE
Tel +47 33 346000
Telefax +47 33 346010
sales.no@kemppi.com

KEMPPI DANMARK A/S

Literbuen 11
DK-2740 SKOVLUNDE
DANMARK
Tel +45 4494 1677
Telefax +45 4494 1536
sales.dk@kemppi.com

KEMPPI BENELUX B.V.

NL-4801 EA BREDA
NEDERLAND
Tel +31 765717750
Telefax +31 765716345
sales.nl@kemppi.com

KEMPPI (UK) LTD

Martti Kempki Building
Fraser Road
Priory Business Park
BEDFORD, MK44 3WH
UNITED KINGDOM
Tel +44 (0)845 6444201

Telefax +44 (0)845 6444202
sales.uk@kemppi.com

KEMPPI FRANCE S.A.S.

65 Avenue de la Couronne des Prés
78681 EPONE CEDEX
FRANCE
Tel +33 1 30 90 04 40
Telefax +33 1 30 90 04 45
sales.fr@kemppi.com

KEMPPI GMBH

Perchstetten 10
D-35428 LANGGÖNS
DEUTSCHLAND
Tel +49 6 403 7792 0
Telefax +49 6 403 779 79 74
sales.de@kemppi.com

KEMPPI SPÓŁKA Z O.O.

Ul. Borzymowska 32
03-565 WARSZAWA
POLAND
Tel +48 22 7816162
Telefax +48 22 7816505
info.pl@kemppi.com

KEMPPI AUSTRALIA PTY LTD

13 Cullen Place
P.O. Box 5256, Greystanes NSW 2145
SMITHFIELD NSW 2164
AUSTRALIA
Tel. +61 2 9605 9500
Telefax +61 2 9605 5999
info.au@kemppi.com

ООО КЕМППИ

Polkovaya str. 1, Building 6
127018 MOSCOW
RUSSIA
Tel +7 495 240 84 03
Telefax +7 495 240 84 07
info.ru@kemppi.com

ООО КЕМППИ

ул. Полковная 1, строение 6
127018 Москва
Tel +7 495 240 84 03
Telefax +7 495 240 84 07
info.ru@kemppi.com

KEMPPI, TRADING (BEIJING) COMPANY LTD

Room 420, 3 Zone, Building B,
No.12 Hongda North Street,
Beijing Economic Development Zone,
100176 BEIJING
CHINA
Tel +86-10-6787 6064
+86-10-6787 1282
Telefax +86-10-6787 5259
sales.cn@kemppi.com

肯倍贸易 (北京) 有限公司
中国北京经济技术开发区宏达北
路12号

创新大厦B座三区420室 (100176)
电话 : +86-10-6787 6064
+86-10-6787 1282
传真 : +86-10-6787 5259
sales.cn@kemppi.com

KEMPPI INDIA PVT LTD

LAKSHMI TOWERS
New No. 2/770,
First Main Road,
Kazura Garden,
Neelankarai,
CHENNAI - 600 041
TAMIL NADU
Tel +91-44-4567 1200
Telefax +91-44-4567 1234
sales.india@kemppi.com

KEMPPI WELDING SOLUTIONS SDN BHD

No 12A, Jalan TP5A,
Taman Perindustrian UEP,
47600 Subang Jaya,
SELANGOR, MALAYSIA
Tel +60 3 80207035
Telefax +60 3 80207835
sales.malaysia@kemppi.com