



OM-246 691B

2011-02

Processes



MIG (GMAW) Welding

Flux Cored (FCAW) Welding

Description



Arc Welding Power Source

Wire Feeder

MigMatic[®] 220/250 Base/DX

CE

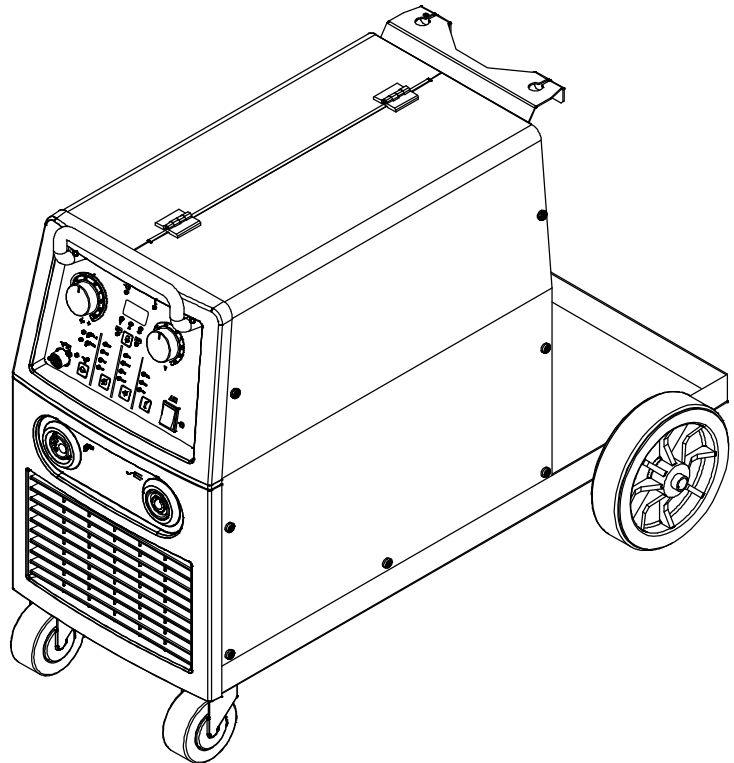

Visit our website at

www.MillerWelds.com

OWNER'S MANUAL

File: MIG (GMAW)



From Miller to You

Thank you and congratulations on choosing Miller. Now you can get the job done and get it done right. We know you don't have time to do it any other way.

That's why when Niels Miller first started building arc welders in 1929, he made sure his products offered long-lasting value and superior quality. Like you, his customers couldn't afford anything less. Miller products had to be more than the best they could be. They had to be the best you could buy.

Today, the people that build and sell Miller products continue the tradition. They're just as committed to providing equipment and service that meets the high standards of quality and value established in 1929.

This Owner's Manual is designed to help you get the most out of your Miller products. Please take time to read the Safety precautions. They will help you protect yourself against potential hazards on the worksite. We've made installation and operation quick and easy. With Miller you can count on years of reliable service with proper maintenance. And if for some reason the unit needs repair, there's a Troubleshooting section that will help you figure out what the problem is. The parts list will then help you to decide which exact part you may need to fix the problem. Warranty and service information for your particular model are also provided.



Miller Electric manufactures a full line of welders and welding related equipment. For information on other quality Miller products, contact your local Miller distributor to receive the latest full line catalog or individual catalog sheets.



Working as hard as you do – every power source from Miller is backed by the most hassle-free warranty in the business.



TABLE OF CONTENTS

SECTION 1 – SAFETY PRECAUTIONS - READ BEFORE USING	1
1-1. Symbol Usage	1
1-2. Arc Welding Hazards	1
1-3. Additional Symbols For Installation, Operation, And Maintenance	3
1-4. California Proposition 65 Warnings	4
1-5. Principal Safety Standards	4
1-6. EMF Information	4
SECTION 2 – DEFINITIONS	5
2-1. WEEE Label	7
2-2. Symbols And Definitions	7
SECTION 3 – INSTALLATION	8
3-1. Important Information Regarding CE Products (Sold Within The EU)	8
3-2. Serial Number And Rating Label Location	8
3-3. Specifications	8
3-4. Duty Cycle And Overheating	8
3-5. Volt-Ampere Curves	9
3-6. Installing Gas Supply	9
3-7. Installing Wire Spool And Adjusting Hub Tension	10
3-8. Positioning Jumper Links (230/400V 3-Phase Models)	11
3-9. Electrical Service Guide	12
3-10. Selecting a Location and Connecting Input Power (1-Phase and 3-Phase)	13
3-11. Installing Drive Rolls And Wire Guide	15
3-12. Threading Welding Wire And Adjusting Pressure Roll Tension	16
SECTION 4 – OPERATION	17
4-1. Controls For MigMatic 220/250	17
4-2. Burnback And Spot Weld Timer Controls	17
4-3. Controls For MigMatic 220 DX / 250 DX	18
4-4. Burnback And Spot Weld Timer Controls	18
4-5. Welding Power Source Input Line Voltage Adjustment (DX Models Only)	19
4-6. Welding Power Source Setup Menu (DX Models Only)	20
4-7. Trigger Mode Selection (DX Models Only)	21
4-8. Spool Gun Mode (DX Models Only)	21
4-9. Welding Wire Diameter Selection For Synergic MIG (DX Models Only)	22
4-10. Welding Wire Type Selection For Synergic MIG (DX Models Only)	22
4-11. Gas Selection For Synergic MIG (DX Models Only)	22
4-12. Selecting Manual MIG Welding (DX Models Only)	23
4-13. Selecting Synergic MIG Welding (DX Models Only)	24
SECTION 5 – MAINTENANCE & TROUBLESHOOTING	25
5-1. Routine Maintenance	25
5-2. Circuit Breaker CB1	25
5-3. Unit Overload	25
5-4. Troubleshooting	26
SECTION 6 – ELECTRICAL DIAGRAMS	28
SECTION 7 – PARTS LIST	32
WARRANTY	



DECLARATION OF CONFORMITY

for European Community (CE marked) products.

ITW Welding Products Italy S.r.l Via Privata Iseo 6/E, 20098 San Giuliano M.se, (MI) Italy declares that the product(s) identified in this declaration conform to the essential requirements and provisions of the stated Council Directive(s) and Standard(s).

Product/Apparatus Identification:

Product	Stock Number
MIGMATIC 220, 230VAC	029015520
MIGMATIC 220 DX, 230VAC	029015521
MIGMATIC 250 230/400VAC	029015524
MIGMATIC 250 DX, 230/400VAC	029015525

Council Directives:

- 2006/95/EC Low Voltage
- 2004/108/EC Electromagnetic Compatibility

Standards:

- IEC 60974-1 Arc Welding Equipment - Welding Power Sources: edition 3, 2005-07.
- IEC 60974-5 Arc Welding Equipment – Wire Feeders: edition 2, 2007-11.
- IEC 60974-10 Arc Welding Equipment - Electromagnetic Compatibility Requirements: edition 2.0, 2007-08.
- EN 50445:2008 Product family standard to demonstrate compliance of equipment for resistance welding, arc welding and allied processes with the basic restrictions related to human exposure to electromagnetic fields (0Hz-300Hz)

EU Signatory:

December 13th, 2010

Massimiliano Lavarini

Date of Declaration

ELECTRONIC ENGINEER R&D TECH. SUPPORT

956 142 835

SECTION 1 – SAFETY PRECAUTIONS - READ BEFORE USING

som 2011-01

 Protect yourself and others from injury — read and follow these precautions.

1-1. Symbol Usage

 **DANGER!** – Indicates a hazardous situation which, if not avoided, will result in death or serious injury. The possible hazards are shown in the adjoining symbols or explained in the text.

 Indicates a hazardous situation which, if not avoided, could result in death or serious injury. The possible hazards are shown in the adjoining symbols or explained in the text.

NOTICE – Indicates statements not related to personal injury.

 Indicates special instructions.



This group of symbols means Warning! Watch Out! ELECTRIC SHOCK, MOVING PARTS, and HOT PARTS hazards. Consult symbols and related instructions below for necessary actions to avoid the hazards.

1-2. Arc Welding Hazards

 The symbols shown below are used throughout this manual to call attention to and identify possible hazards. When you see the symbol, watch out, and follow the related instructions to avoid the hazard. The safety information given below is only a summary of the more complete safety information found in the Safety Standards listed in Section 1-5. Read and follow all Safety Standards.

 Only qualified persons should install, operate, maintain, and repair this unit.

 During operation, keep everybody, especially children, away.



ELECTRIC SHOCK can kill.

Touching live electrical parts can cause fatal shocks or severe burns. The electrode and work circuit is electrically live whenever the output is on. The input power circuit and machine internal circuits are also live when power is on. In semiautomatic or automatic wire welding, the wire, wire reel, drive roll housing, and all metal parts touching the welding wire are electrically live. Incorrectly installed or improperly grounded equipment is a hazard.

- Do not touch live electrical parts.

- Wear dry, hole-free insulating gloves and body protection.
- Insulate yourself from work and ground using dry insulating mats or covers big enough to prevent any physical contact with the work or ground.
- Do not use AC output in damp areas, if movement is confined, or if there is a danger of falling.
- Use AC output ONLY if required for the welding process.
- If AC output is required, use remote output control if present on unit.
- Additional safety precautions are required when any of the following electrically hazardous conditions are present: in damp locations or while wearing wet clothing; on metal structures such as floors, gratings, or scaffolds; when in cramped positions such as sitting, kneeling, or lying; or when there is a high risk of unavoidable or accidental contact with the workpiece or ground. For these conditions, use the following equipment in order presented: 1) a semiautomatic DC constant voltage (wire) welder, 2) a DC manual (stick) welder, or 3) an AC welder with reduced open-circuit voltage. In most situations, use of a DC, constant voltage wire welder is recommended. And, do not work alone!
- Disconnect input power or stop engine before installing or servicing this equipment. Lockout/tagout input power according to OSHA 29 CFR 1910.147 (see Safety Standards).
- Properly install and ground this equipment according to its Owner's Manual and national, state, and local codes.

- Always verify the supply ground – check and be sure that input power cord ground wire is properly connected to ground terminal in disconnect box or that cord plug is connected to a properly grounded receptacle outlet.
- When making input connections, attach proper grounding conductor first – double-check connections.
- Keep cords dry, free of oil and grease, and protected from hot metal and sparks.
- Frequently inspect input power cord for damage or bare wiring – replace cord immediately if damaged – bare wiring can kill.
- Turn off all equipment when not in use.
- Do not use worn, damaged, undersized, or poorly spliced cables.
- Do not drape cables over your body.
- If earth grounding of the workpiece is required, ground it directly with a separate cable.
- Do not touch electrode if you are in contact with the work, ground, or another electrode from a different machine.
- Do not touch electrode holders connected to two welding machines at the same time since double open-circuit voltage will be present.
- Use only well-maintained equipment. Repair or replace damaged parts at once. Maintain unit according to manual.
- Wear a safety harness if working above floor level.
- Keep all panels and covers securely in place.
- Clamp work cable with good metal-to-metal contact to workpiece or worktable as near the weld as practical.
- Insulate work clamp when not connected to workpiece to prevent contact with any metal object.
- Do not connect more than one electrode or work cable to any single weld output terminal.

SIGNIFICANT DC VOLTAGE exists in inverter welding power sources AFTER removal of input power.

- Turn Off inverter, disconnect input power, and discharge input capacitors according to instructions in Maintenance Section before touching any parts.



HOT PARTS can burn.

- Do not touch hot parts bare handed.
- Allow cooling period before working on equipment.
- To handle hot parts, use proper tools and/or wear heavy, insulated welding gloves and clothing to prevent burns.



FUMES AND GASES can be hazardous.

Welding produces fumes and gases. Breathing these fumes and gases can be hazardous to your health.

- Keep your head out of the fumes. Do not breathe the fumes.
- If inside, ventilate the area and/or use local forced ventilation at the arc to remove welding fumes and gases.
- If ventilation is poor, wear an approved air-supplied respirator.
- Read and understand the Material Safety Data Sheets (MSDSs) and the manufacturer's instructions for metals, consumables, coatings, cleaners, and degreasers.
- Work in a confined space only if it is well ventilated, or while wearing an air-supplied respirator. Always have a trained watch-person nearby. Welding fumes and gases can displace air and lower the oxygen level causing injury or death. Be sure the breathing air is safe.
- Do not weld in locations near degreasing, cleaning, or spraying operations. The heat and rays of the arc can react with vapors to form highly toxic and irritating gases.
- Do not weld on coated metals, such as galvanized, lead, or cadmium plated steel, unless the coating is removed from the weld area, the area is well ventilated, and while wearing an air-supplied respirator. The coatings and any metals containing these elements can give off toxic fumes if welded.



ARC RAYS can burn eyes and skin.

Arc rays from the welding process produce intense visible and invisible (ultraviolet and infrared) rays that can burn eyes and skin. Sparks fly off from the weld.

- Wear an approved welding helmet fitted with a proper shade of filter lenses to protect your face and eyes from arc rays and sparks when welding or watching (see ANSI Z49.1 and Z87.1 listed in Safety Standards).
- Wear approved safety glasses with side shields under your helmet.
- Use protective screens or barriers to protect others from flash, glare and sparks; warn others not to watch the arc.
- Wear protective clothing made from durable, flame-resistant material (leather, heavy cotton, or wool) and foot protection.



WELDING can cause fire or explosion.

Welding on closed containers, such as tanks, drums, or pipes, can cause them to blow up. Sparks can fly off from the welding arc. The flying sparks, hot workpiece, and hot equipment can cause fires and burns. Accidental contact of electrode to metal objects can cause sparks, explosion, overheating, or fire. Check and be sure the area is safe before doing any welding.

- Remove all flammables within 35 ft (10.7 m) of the welding arc. If this is not possible, tightly cover them with approved covers.
- Do not weld where flying sparks can strike flammable material.
- Protect yourself and others from flying sparks and hot metal.
- Be alert that welding sparks and hot materials from welding can easily go through small cracks and openings to adjacent areas.
- Watch for fire, and keep a fire extinguisher nearby.
- Be aware that welding on a ceiling, floor, bulkhead, or partition can cause fire on the hidden side.
- Do not weld on closed containers such as tanks, drums, or pipes, unless they are properly prepared according to AWS F4.1 (see Safety Standards).
- Do not weld where the atmosphere may contain flammable dust, gas, or liquid vapors (such as gasoline).
- Connect work cable to the work as close to the welding area as practical to prevent welding current from traveling long, possibly unknown paths and causing electric shock, sparks, and fire hazards.
- Do not use welder to thaw frozen pipes.

- Remove stick electrode from holder or cut off welding wire at contact tip when not in use.
- Wear oil-free protective garments such as leather gloves, heavy shirt, cuffless trousers, high shoes, and a cap.
- Remove any combustibles, such as a butane lighter or matches, from your person before doing any welding.
- After completion of work, inspect area to ensure it is free of sparks, glowing embers, and flames.
- Use only correct fuses or circuit breakers. Do not oversize or bypass them.
- Follow requirements in OSHA 1910.252 (a) (2) (iv) and NFPA 51B for hot work and have a fire watcher and extinguisher nearby.

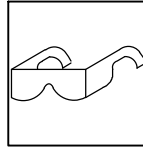

FLYING METAL or DIRT can injure eyes.

- Welding, chipping, wire brushing, and grinding cause sparks and flying metal. As welds cool, they can throw off slag.
- Wear approved safety glasses with side shields even under your welding helmet.



BUILDUP OF GAS can injure or kill.

- Shut off compressed gas supply when not in use.
- Always ventilate confined spaces or use approved air-supplied respirator.

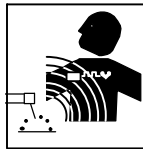

ELECTRIC AND MAGNETIC FIELDS (EMF) can affect Implanted Medical Devices.

- Wearers of Pacemakers and other Implanted Medical Devices should keep away.
- Implanted Medical Device wearers should consult their doctor and the device manufacturer before going near arc welding, spot welding, gouging, plasma arc cutting, or induction heating operations.

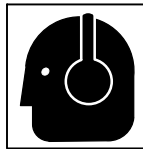

NOISE can damage hearing.

Noise from some processes or equipment can damage hearing.

- Wear approved ear protection if noise level is high.

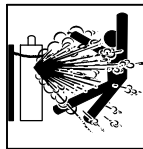

CYLINDERS can explode if damaged.

Compressed gas cylinders contain gas under high pressure. If damaged, a cylinder can explode. Since gas cylinders are normally part of the welding process, be sure to treat them carefully.

- Protect compressed gas cylinders from excessive heat, mechanical shocks, physical damage, slag, open flames, sparks, and arcs.
- Install cylinders in an upright position by securing to a stationary support or cylinder rack to prevent falling or tipping.
- Keep cylinders away from any welding or other electrical circuits.
- Never drape a welding torch over a gas cylinder.
- Never allow a welding electrode to touch any cylinder.
- Never weld on a pressurized cylinder – explosion will result.
- Use only correct compressed gas cylinders, regulators, hoses, and fittings designed for the specific application; maintain them and associated parts in good condition.
- Turn face away from valve outlet when opening cylinder valve.
- Keep protective cap in place over valve except when cylinder is in use or connected for use.
- Use the right equipment, correct procedures, and sufficient number of persons to lift and move cylinders.
- Read and follow instructions on compressed gas cylinders, associated equipment, and Compressed Gas Association (CGA) publication P-1 listed in Safety Standards.

1-3. Additional Symbols For Installation, Operation, And Maintenance



FIRE OR EXPLOSION hazard.

- Do not install or place unit on, over, or near combustible surfaces.
- Do not install unit near flammables.
- Do not overload building wiring – be sure power supply system is properly sized, rated, and protected to handle this unit.



FALLING EQUIPMENT can injure.

- Use lifting eye to lift unit only, NOT running gear, gas cylinders, or any other accessories.
- Use equipment of adequate capacity to lift and support unit.
- If using lift forks to move unit, be sure forks are long enough to extend beyond opposite side of unit.
- Keep equipment (cables and cords) away from moving vehicles when working from an aerial location.
- Follow the guidelines in the Applications Manual for the Revised NIOSH Lifting Equation (Publication No. 94-110) when manually lifting heavy parts or equipment.

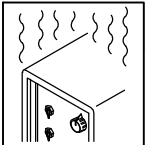

OVERUSE can cause OVERHEATING

- Allow cooling period; follow rated duty cycle.
- Reduce current or reduce duty cycle before starting to weld again.
- Do not block or filter airflow to unit.

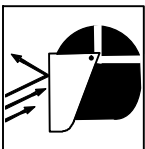

FLYING SPARKS can injure.

- Wear a face shield to protect eyes and face.
- Shape tungsten electrode only on grinder with proper guards in a safe location wearing proper face, hand, and body protection.
- Sparks can cause fires — keep flammables away.

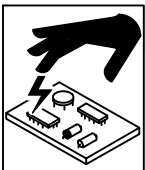

STATIC (ESD) can damage PC boards.

- Put on grounded wrist strap BEFORE handling boards or parts.
- Use proper static-proof bags and boxes to store, move, or ship PC boards.



MOVING PARTS can injure.

- Keep away from moving parts.
- Keep away from pinch points such as drive rolls.



WELDING WIRE can injure.

- Do not press gun trigger until instructed to do so.
- Do not point gun toward any part of the body, other people, or any metal when threading welding wire.



MOVING PARTS can injure.

- Keep away from moving parts such as fans.
- Keep all doors, panels, covers, and guards closed and securely in place.
- Have only qualified persons remove doors, panels, covers, or guards for maintenance and troubleshooting as necessary.
- Reinstall doors, panels, covers, or guards when maintenance is finished and before reconnecting input power.

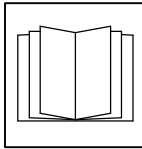

READ INSTRUCTIONS.

- Read and follow all labels and the Owner's Manual carefully before installing, operating, or servicing unit. Read the safety information at the beginning of the manual and in each section.
- Use only genuine replacement parts from the manufacturer.
- Perform maintenance and service according to the Owner's Manuals, industry standards, and national, state, and local codes.

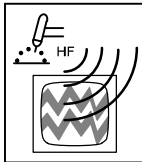

H.F. RADIATION can cause interference.

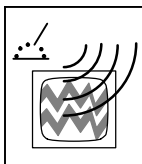

- High-frequency (H.F.) can interfere with radio navigation, safety services, computers, and communications equipment.
- Have only qualified persons familiar with electronic equipment perform this installation.
- The user is responsible for having a qualified electrician promptly correct any interference problem resulting from the installation.
- If notified by the FCC about interference, stop using the equipment at once.
- Have the installation regularly checked and maintained.
- Keep high-frequency source doors and panels tightly shut, keep spark gaps at correct setting, and use grounding and shielding to minimize the possibility of interference.



ARC WELDING can cause interference.

- Electromagnetic energy can interfere with sensitive electronic equipment such as computers and computer-driven equipment such as robots.
- Be sure all equipment in the welding area is electromagnetically compatible.
- To reduce possible interference, keep weld cables as short as possible, close together, and down low, such as on the floor.
- Locate welding operation 100 meters from any sensitive electronic equipment.
- Be sure this welding machine is installed and grounded according to this manual.
- If interference still occurs, the user must take extra measures such as moving the welding machine, using shielded cables, using line filters, or shielding the work area.

1-4. California Proposition 65 Warnings

-  **Welding or cutting equipment produces fumes or gases which contain chemicals known to the State of California to cause birth defects and, in some cases, cancer. (California Health & Safety Code Section 25249.5 et seq.)**
-  **Battery posts, terminals and related accessories contain lead and lead compounds, chemicals known to the State of California to cause cancer and birth defects or other reproductive harm. *Wash hands after handling.***
-  **This product contains chemicals, including lead, known to the state of California to cause cancer, birth defects, or other reproductive harm. *Wash hands after use.***

For Gasoline Engines:

-  **Engine exhaust contains chemicals known to the State of California to cause cancer, birth defects, or other reproductive harm.**

For Diesel Engines:

-  **Diesel engine exhaust and some of its constituents are known to the State of California to cause cancer, birth defects, and other reproductive harm.**

1-5. Principal Safety Standards

Safety in Welding, Cutting, and Allied Processes, ANSI Standard Z49.1, from Global Engineering Documents (phone: 1-877-413-5184, website: www.global.ihs.com).

Safe Practices for the Preparation of Containers and Piping for Welding and Cutting, American Welding Society Standard AWS F4.1, from Global Engineering Documents (phone: 1-877-413-5184, website: www.global.ihs.com).

National Electrical Code, NFPA Standard 70, from National Fire Protection Association, Quincy, MA 02269 (phone: 1-800-344-3555, website: www.nfpa.org and www.sparky.org).

Safe Handling of Compressed Gases in Cylinders, CGA Pamphlet P-1, from Compressed Gas Association, 4221 Walney Road, 5th Floor, Chantilly, VA 20151 (phone: 703-788-2700, website: www.cganet.com).

Safety in Welding, Cutting, and Allied Processes, CSA Standard W117.2, from Canadian Standards Association, Standards Sales, 5060 Spectrum Way, Suite 100, Ontario, Canada L4W 5NS (phone: 800-463-6727, website: www.csa-international.org).

Safe Practice For Occupational And Educational Eye And Face Protection, ANSI Standard Z87.1, from American National Standards Institute,

25 West 43rd Street, New York, NY 10036 (phone: 212-642-4900, website: www.ansi.org).

Standard for Fire Prevention During Welding, Cutting, and Other Hot Work, NFPA Standard 51B, from National Fire Protection Association, Quincy, MA 02269 (phone: 1-800-344-3555, website: www.nfpa.org).

OSHA, Occupational Safety and Health Standards for General Industry, Title 29, Code of Federal Regulations (CFR), Part 1910, Subpart Q, and Part 1926, Subpart J, from U.S. Government Printing Office, Superintendent of Documents, P.O. Box 371954, Pittsburgh, PA 15250-7954 (phone: 1-866-512-1800) (there are 10 OSHA Regional Offices—phone for Region 5, Chicago, is 312-353-2220, website: www.osha.gov).

U.S. Consumer Product Safety Commission (CPSC), 4330 East West Highway, Bethesda, MD 20814 (phone: 301-504-7923, website: www.cpsc.gov).

Applications Manual for the Revised NIOSH Lifting Equation, The National Institute for Occupational Safety and Health (NIOSH), 1600 Clifton Rd, Atlanta, GA 30333 (phone: 1-800-232-4636, website: www.cdc.gov/NIOSH).

1-6. EMF Information

Electric current flowing through any conductor causes localized electric and magnetic fields (EMF). Welding current creates an EMF field around the welding circuit and welding equipment. EMF fields may interfere with some medical implants, e.g. pacemakers. Protective measures for persons wearing medical implants have to be taken. For example, access restrictions for passers-by or individual risk assessment for welders. All welders should use the following procedures in order to minimize exposure to EMF fields from the welding circuit:

1. Keep cables close together by twisting or taping them, or using a cable cover.
2. Do not place your body between welding cables. Arrange cables to one side and away from the operator.
3. Do not coil or drape cables around your body.

4. Keep head and trunk as far away from the equipment in the welding circuit as possible.
5. Connect work clamp to workpiece as close to the weld as possible.
6. Do not work next to, sit or lean on the welding power source.
7. Do not weld whilst carrying the welding power source or wire feeder.

About Implanted Medical Devices:

Implanted Medical Device wearers should consult their doctor and the device manufacturer before performing or going near arc welding, spot welding, gouging, plasma arc cutting, or induction heating operations. If cleared by your doctor, then following the above procedures is recommended.

SECTION 2 – DEFINITIONS

Warning! Watch Out! There are possible hazards as shown by the symbols.

1 Electric shock can kill.

1.1 Wear dry insulating gloves. Do not touch electrode with bare hand. Do not wear wet or damaged gloves.

1.2 Protect yourself from electric shock by insulating yourself from work and ground.

1.3 Disconnect input plug or power before working on machine.

2 Breathing welding fumes can be hazardous to your health.

2.1 Keep your head out of the fumes.

2.2 Use forced ventilation or local exhaust to remove the fumes.

2.3 Use ventilating fan to remove fumes.

3 Welding sparks can cause explosion or fire.

3.1 Keep flammables away from welding. Do not weld near flammables.

3.2 Welding sparks can cause fires. Have a fire extinguisher nearby, and have a watchperson ready to use it.

3.3 Do not weld on drums or any closed containers.

4 Arc rays can burn eyes and injure skin.

4.1 Wear hat and safety glasses. Use ear protection and button shirt collar. Use welding helmet with correct shade of filter. Wear complete body protection.

5 Become trained and read the instructions before working on the machine or welding.

6 Do not remove or paint over (cover) the label.

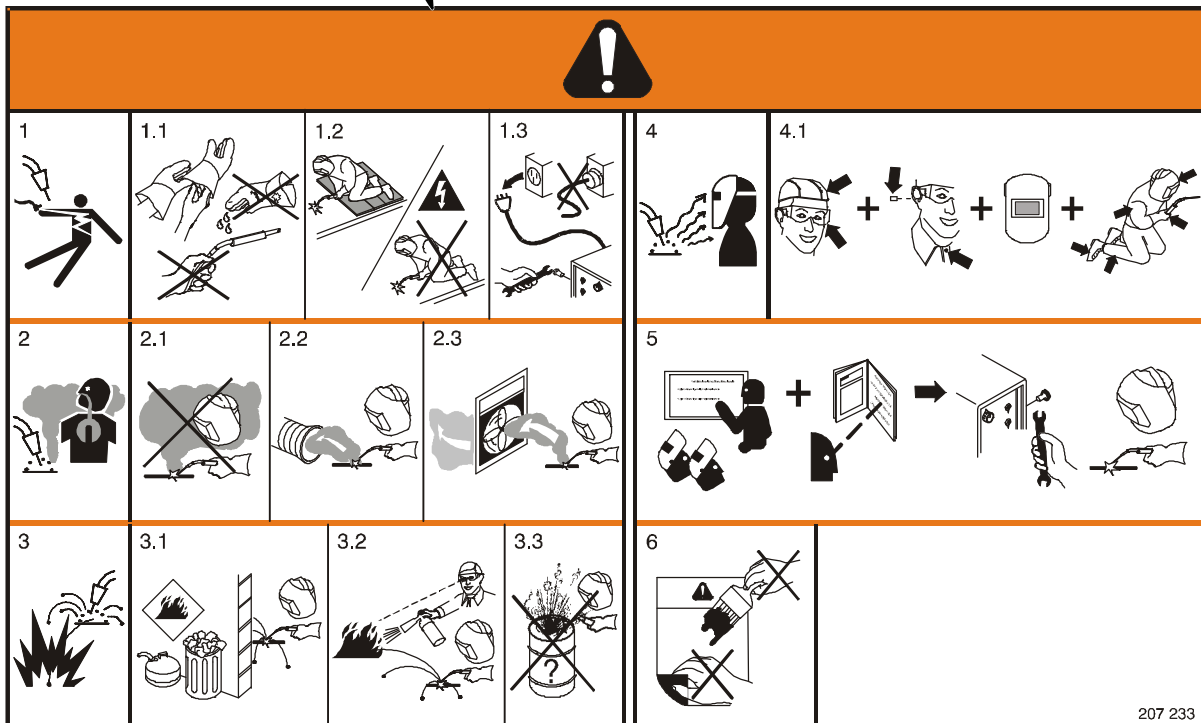

207 233

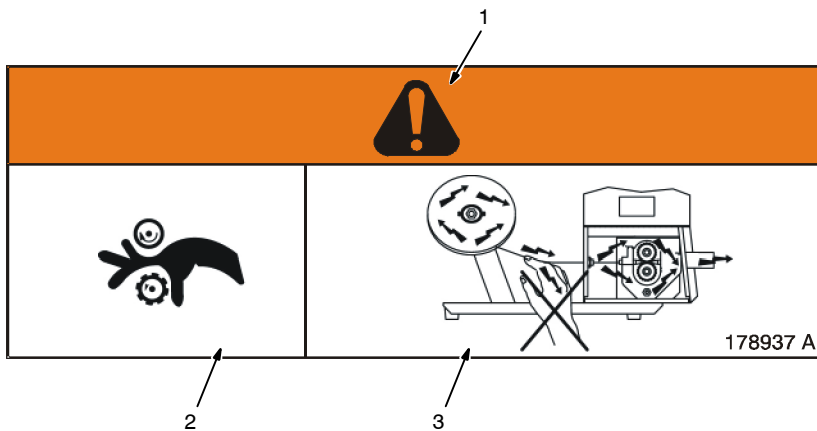

1 Warning! Watch Out! There are possible hazards as shown by the symbols.

2 Drive rolls can injure fingers

3 Welding wire and drive parts are at welding voltage during operation – keep hands and metal objects away.

178937 A

Warning! Watch Out! There are possible hazards as shown by the symbols.

Electric shock from wiring can kill.

Disconnect input plug or power before working on machine.

Read the Owner's Manual before working on this machine.

- 1 Consult rating label for input power requirements, and check power available at the job site – they must match.
- 2 Read Owner's Manual and inside labels for connection points and procedures.
- 3 Move jumper links as shown on inside label to match voltage at job site.
- 4 Having a loop of extra length, connect grounding conductor first.
- 5 Connect line input conductors as shown on inside label – double-check all connections, jumper link positions, and input voltage before applying power.

207 291

- 1 Warning! Watch Out! There are possible hazards as shown by the symbols.
- 2 Moving parts, such as fans, can cut fingers and hands and cause injury. Keep away from moving parts.

S-176 106

- 1 Warning! Watch Out! There are possible hazards as shown by the symbols.
- 2 Falling unit can cause injury. Do not move or operate unit where it could tip.
- 3 Cylinders can explode if damaged. Protect compressed gas cylinders from excessive heat, mechanical shock, slag, open flames, sparks, and arcs.

207 235

2-1. WEEE Label

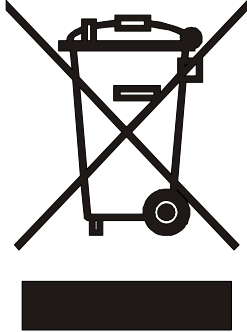













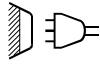





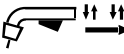

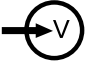

Do not discard this product with general waste.

Reuse or recycle Waste Electrical and Electronic Equipment (WEEE) by disposing at a designated collection facility.

Contact your local recycling office or your local distributor for further information.

2-2. Symbols And Definitions

A	Amperes	V	Volts		Alternating Current (AC)		Direct Current (DC)
	Remote	I	On		Off		Protective Earth (Ground)
	Line Connection	3 	Three Phase	1 	Single Phase		Gas Metal Arc Welding (GMAW)
U₁	Primary Voltage	I_{1max}	Rated Maximum Supply Current	I_{1eff}	Maximum Effective Supply Current	U₂	Conventional Load Voltage
I₂	Rated Welding Current	X	Duty Cycle	%	Percent	U₀	Rated No Load Voltage (Average)
IP	Degree Of Protection		Circuit Breaker		Three Phase Transformer Rectifier		Two-Step Trigger Operation
	Four-Step Trigger Operation		Gas Input		Gas Output		Gas Type
	Voltage Input		Wire Feed Spool Gun		Wire Feed	Hz	Hertz
	Read Operator's Manual		Wire Type		Diameter		Spot Weld Time
	Wire Burnback Control		Wire Run-In Speed Control				

SECTION 3 – INSTALLATION

3-1. Important Information Regarding CE Products (Sold Within The EU)

⚠ This equipment shall not be used by the general public as the EMF limits for the general public might be exceeded during welding.

This equipment is built in accordance with EN 60974–1 and is intended to be used only in an occupational environment (where the general public access is prohibited or regulated in such a way as to be similar to occupational use) by an expert or an instructed person.

Wire feeders and ancillary equipment (such as torches, liquid cooling systems and arc striking and stabilizing devices) as part of the welding circuit may not be a major contributor to the EMF. See the Owner's Manuals for all components of the welding circuit for additional EMF exposure information.

- The EMF assessment on this equipment was conducted at 0.5 meter.
- At a distance of 1 meter the EMF exposure values were less than 20% of the permissible values.

3-2. Serial Number And Rating Label Location

The serial number and rating information for this product is located on back panel. Use rating label to determine input power requirements and/or rated output. For future reference, write serial number in space provided on back cover of this manual.

3-3. Specifications

Model	Rated Output			Max. Open Circuit Voltage	Amperage Range DC	IP Rating	Dimension (mm)	Weight (kg)
	100%	60%	20%					
220 230 VAC 50/60 Hz	90 A 18.5 V	116 A 19.8 V	200 A 24.0 V	40.2	30-200 A	IP23S	350 x 575 x 920	64 Net

Wire feed speed range 1.3 mpm to 20 mpm.

Model	Rated Output			Max. Open Circuit Voltage	Amperage Range DC	IP Rating	Dimension (mm)	Weight (kg)
	100%	60%	35%					
250 230/400 VAC 50/60 Hz	145 A 21.0 V	190 A 23.0 V	250 A 26.5 V	43.0 V	30-250 A	IP23S	350 x 575 x 920	73 Net

Wire feed speed range 1.3 mpm to 20 mpm.

3-4. Duty Cycle And Overheating

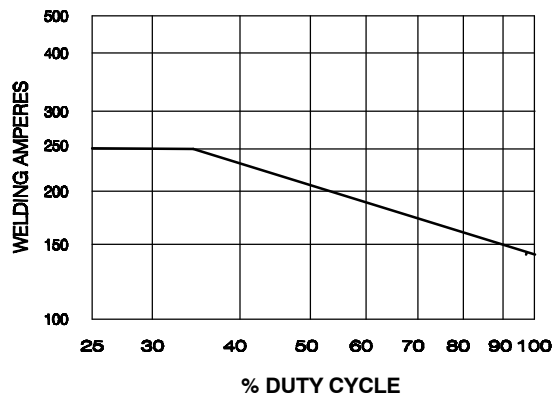

Duty Cycle is percentage of 10 minutes that unit can weld at rated load without overheating.

If unit overheats, thermostat(s) opens, output stops, and cooling fan runs. Wait fifteen minutes for unit to cool. Reduce amperage or voltage, or duty cycle before welding.

NOTICE – Exceeding duty cycle can damage unit and void warranty.

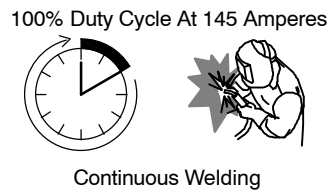
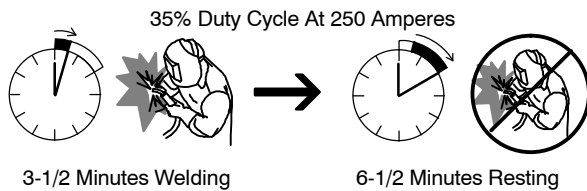

Overheating

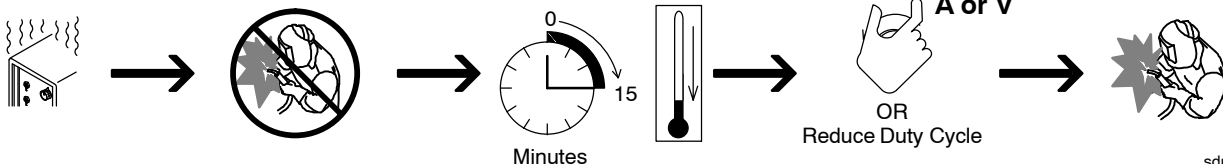

sduty1 5/95

3-5. Volt-Ampere Curves

The volt-ampere curves show the normal minimum and maximum voltage and amperage output capabilities of the welding power source. Curves of other settings fall between the curves shown.

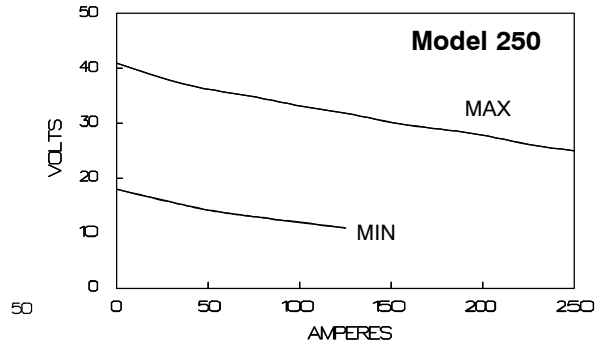
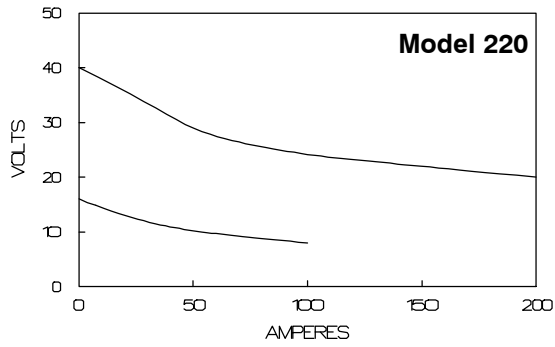

3-6. Installing Gas Supply

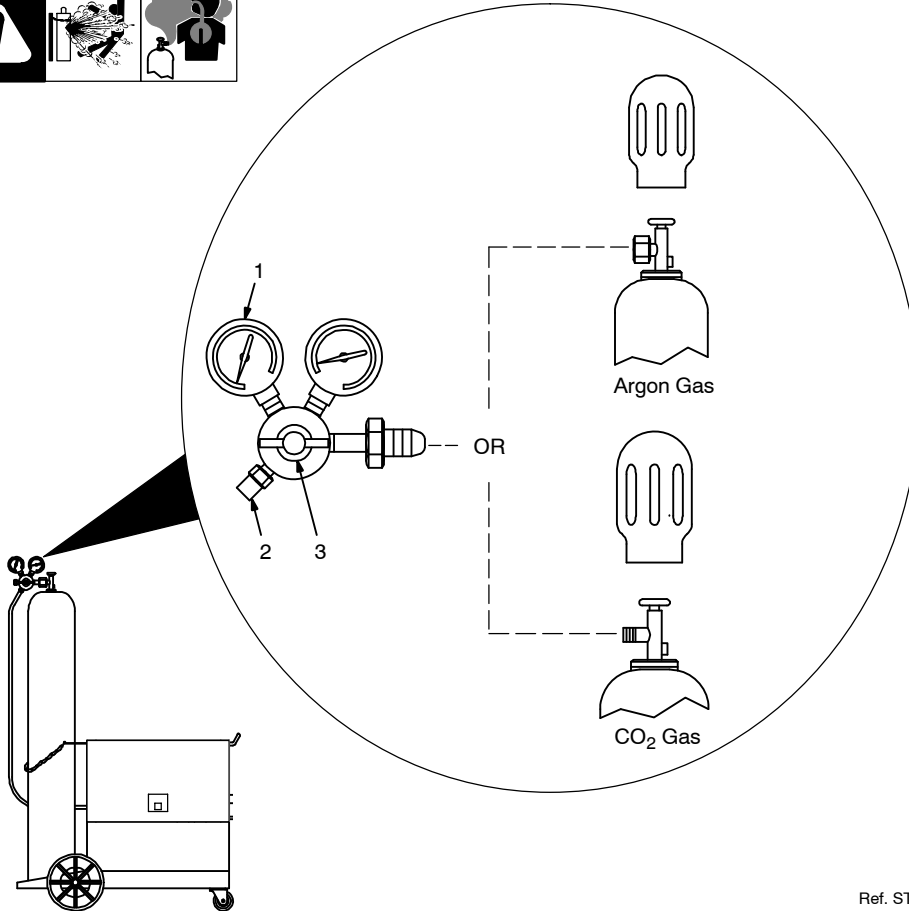

Chain gas cylinder to running gear, wall, or other stationary support so cylinder cannot fall and break off valve.

- 1 Regulator/Flow Gauge
Install so face is vertical.
- 2 Gas Hose Connection
- 3 Flow Adjust

Typical flow rate is 0.9 liters per minute. Check wire manufacturer's recommended flow rate. This flow gauge can be adjusted between 2.36 and 11.8 liters per minute.

3-7. Installing Wire Spool And Adjusting Hub Tension



1 Spacers
Use only for 5Kg spool.

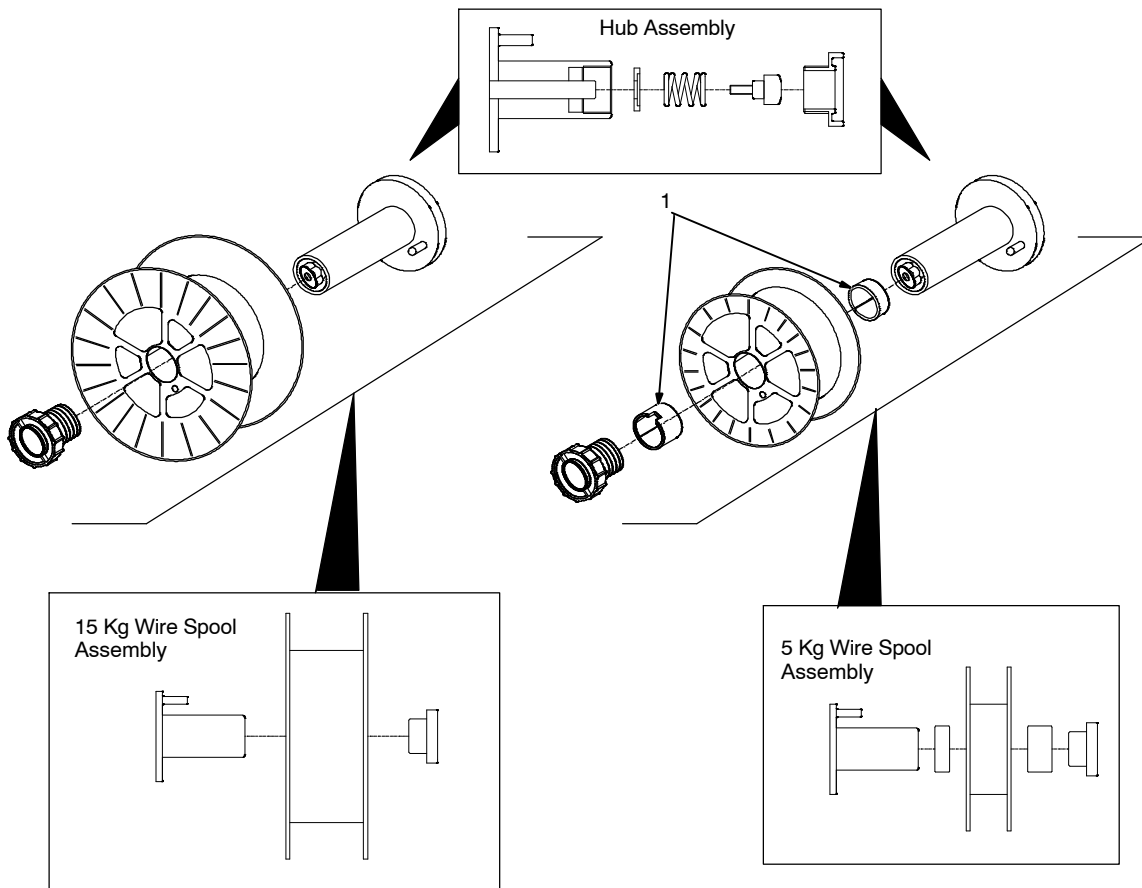

Tools Needed:



Ref. D2

3-8. Positioning Jumper Links (230/400V 3-Phase Models)



⚠ Disconnect and lockout/tag-out input power before installing or moving jumper links.

Check input voltage available at site.

1 Jumper Link Label

Check label – only one is on unit.

2 Jumper Links

Move jumper links to match input voltage.

Close and secure access door.

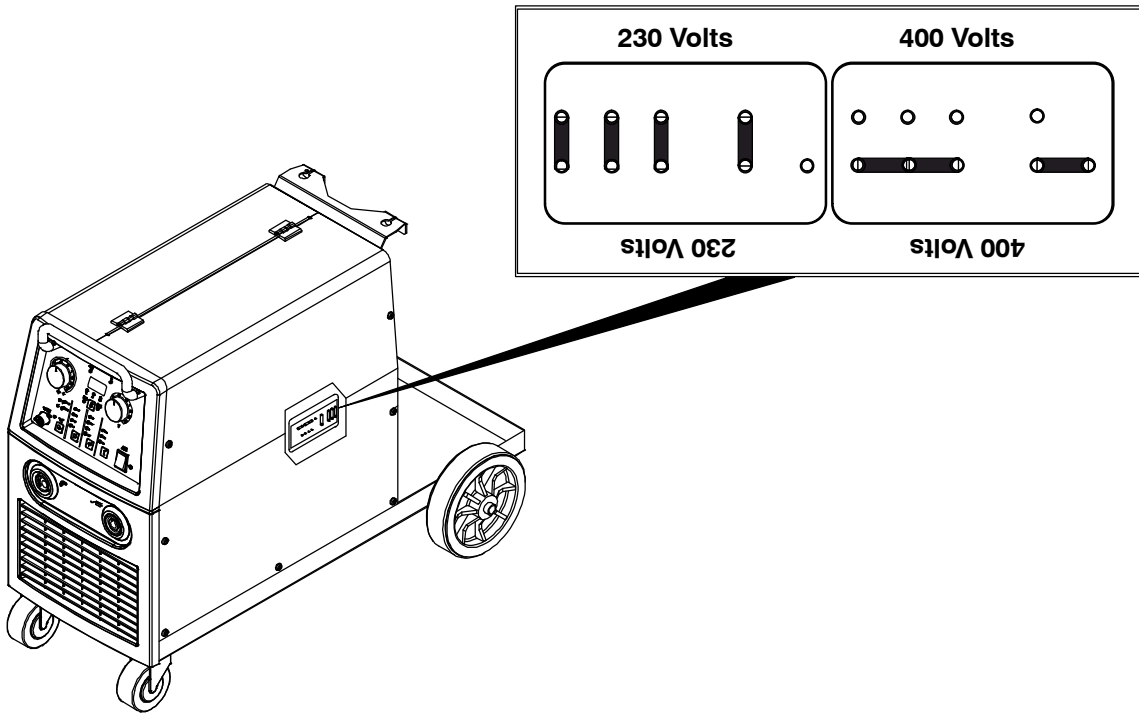

3-9. Electrical Service Guide



Failure to follow these electrical service guide recommendations could create an electric shock or fire hazard. These recommendations are for a dedicated branch circuit sized for the rated output and duty cycle of the welding power source.

⚡ Power cord supplied with unit is sized for 230 volt operation. Larger power cord may be required for cable length greater than 3 meters. Consult national or local regulations.

MigMatic Model	220	250	
	50/60 Hz Single Phase	50/60 Hz	Three Phase
Input Voltage (V)	230	230	400
Input Amperes (A) At Rated Output	34	28	16
Max Recommended Standard Fuse Rating In Amperes ¹			
Time-Delay Fuses ²	40	30	15
Normal Operating Fuses ³	50	40	25
Min Input Conductor Size In mm2 (AWG) ⁴	10 (8)	6 (10)	4 (12)
Max Recommended Input Conductor Length In Meters (Feet)	41 (134)	38 (124)	69 (226)
Min Grounding Conductor Size In mm2 (AWG) ⁴	6 (10)	6 (10)	4 (12)

Reference: 2008 National Electrical Code (NEC) (including article 630)

1 If a circuit breaker is used in place of a fuse, choose a circuit breaker with time-current curves comparable to the recommended fuse.

2 “Time-Delay” fuses are UL class “RK5” . See UL 248.

3 “Normal Operating” (general purpose - no intentional delay) fuses are UL class “K5” (up to and including 60 amps), and UL class “H” (65 amps and above).

4 Conductor data in this section specifies conductor size (excluding flexible cord or cable) between the panelboard and the equipment per NEC Table 310.16. If a flexible cord or cable is used, minimum conductor size may increase. See NEC Table 400.5(A) for flexible cord and cable requirements.

Notes

3-10. Selecting a Location and Connecting Input Power (1-Phase and 3-Phase)

A. 1-Phase

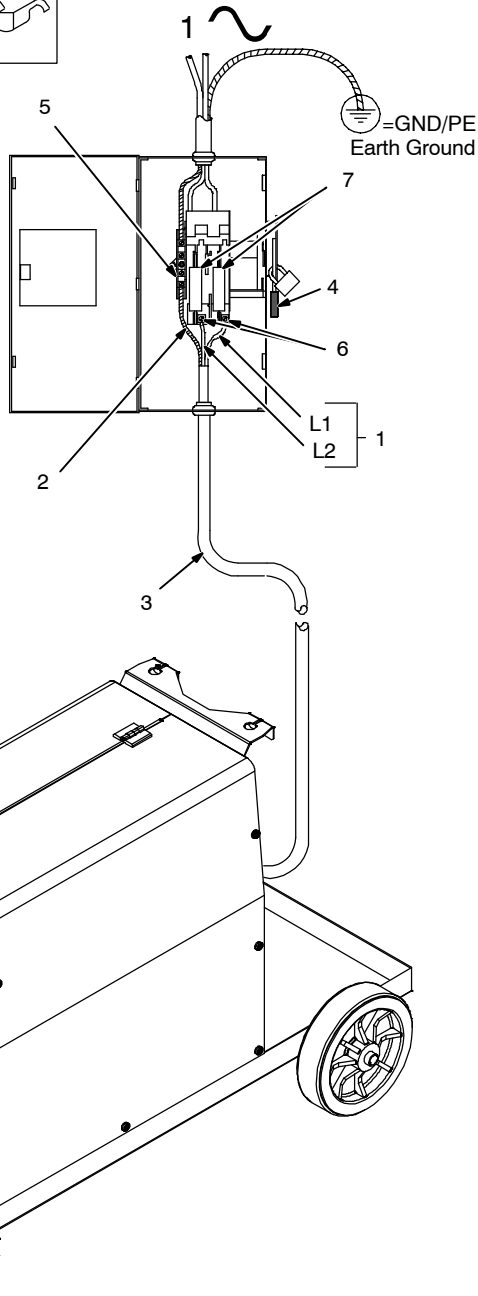
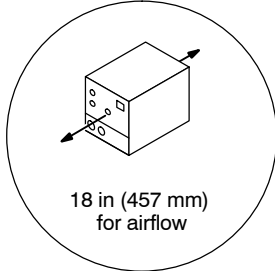
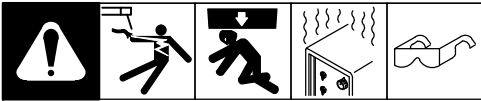

! Installation must meet all National and Local Codes – have only qualified persons make this installation.

! Disconnect and lockout/tagout input power before connecting input conductors from unit.

! Always connect green or green/yellow conductor to supply grounding terminal first, and never to a line terminal.

- 1 Black And White Input Conductor (L1 And L2)
- 2 Green Or Green/Yellow Grounding Conductor
- 3 Input Power Cord.
- 4 Disconnect Device (switch shown in the OFF position)
- 5 Disconnect Device Grounding Terminal
- 6 Disconnect Device Line Terminals

Connect green or green/yellow grounding conductor to disconnect device grounding terminal first.

Connect input conductors L1 and L2 to disconnect device line terminals.

7 Over-Current Protection

Select type and size of over-current protection using Section 3-9 (fused disconnect switch shown).

Close and secure door on disconnect device. Remove lockout/tagout device, and place switch in the On position.

Tools Needed:



Ref. D4

B. 3-Phase

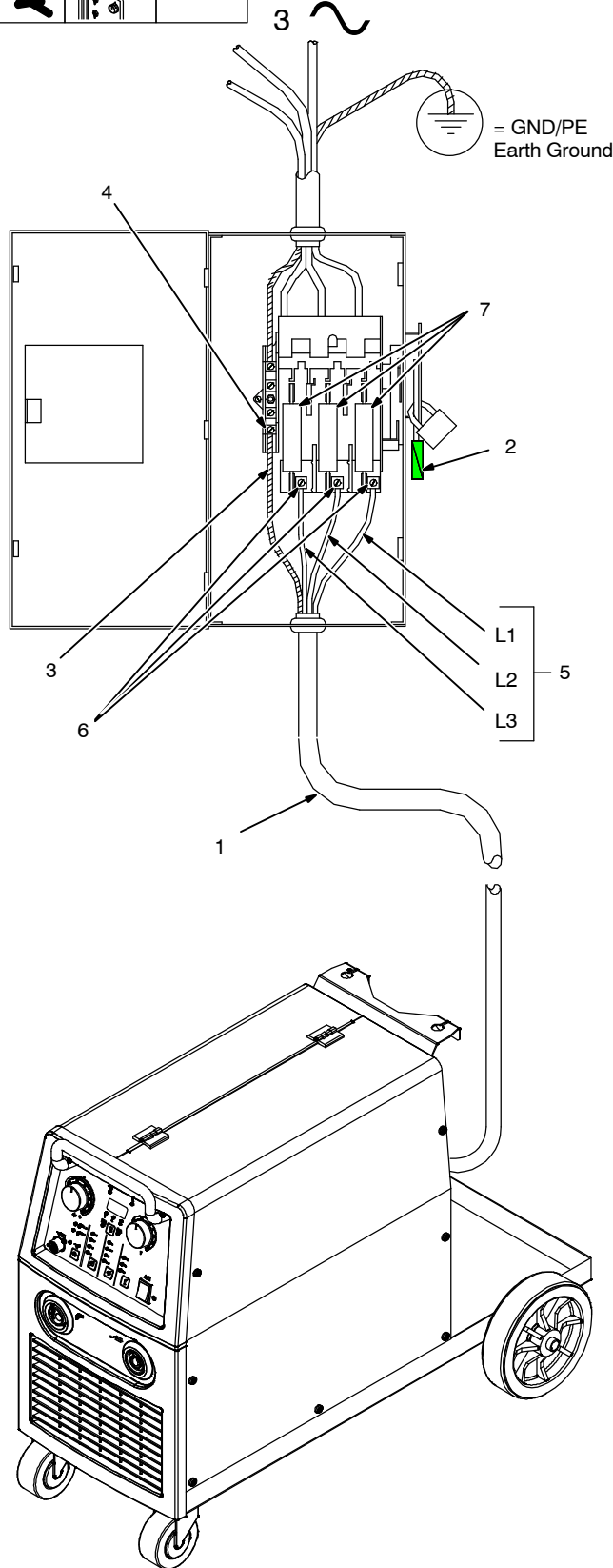

⚠ Installation must meet all National and Local Codes – have only qualified persons make this installation.

⚠ Disconnect and lockout/tagout input power before connecting input conductors from unit.

⚠ Always connect green or green/yellow conductor to supply grounding terminal first, and never to a line terminal.

For Three-Phase Operation

- 1 Input Power Cord.
- 2 Disconnect Device (switch shown in the OFF position)
- 3 Green Or Green/Yellow Grounding Conductor
- 4 Disconnect Device Grounding Terminal
- 5 Input Conductors (L1, L2 And L3)
- 6 Disconnect Device Line Terminals

Connect green or green/yellow grounding conductor to disconnect device grounding terminal first.

Connect input conductors L1, L2, and L3 to disconnect device line terminals.

7 Over-Current Protection

Select type and size of over-current protection using Section 3-9 (fused disconnect switch shown).

Close and secure door on disconnect device. Remove lockout/tagout device, and place switch in the On position.

Tools Needed:

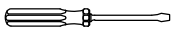

Ref. D5

3-12. Threading Welding Wire And Adjusting Pressure Roll Tension



- 1 Wire Spool
 - 2 Welding Wire
 - 3 Inlet Wire Guide
 - 4 Pressure Adjustment Knob
 - 5 Drive Roll
 - 6 Outlet Wire Guide
 - 7 Gun Conduit Cable
- Lay gun cable out straight.

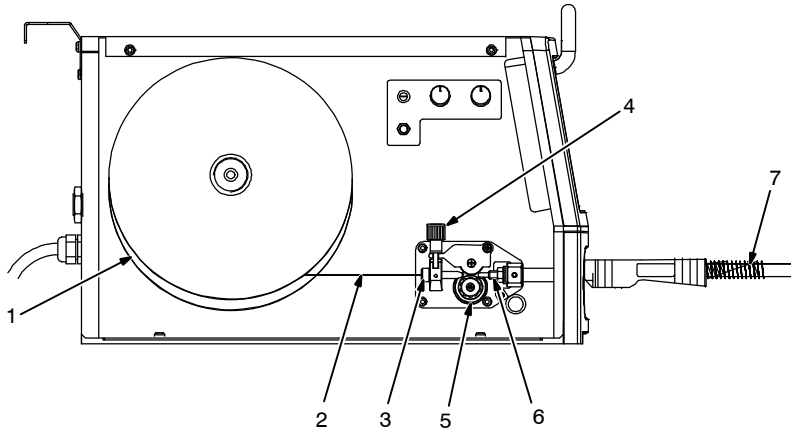

Tools Needed:

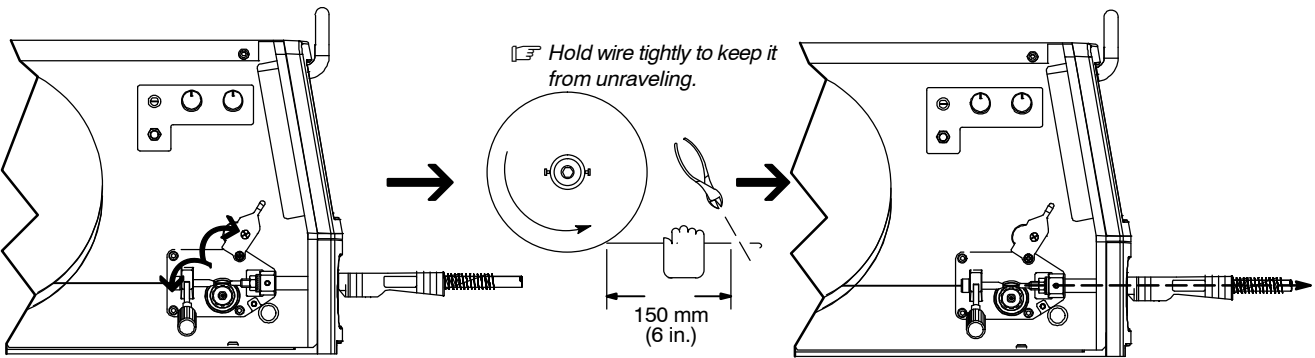
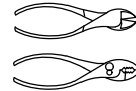

Open pressure assembly.

Pull and hold wire; cut off end.

Push wire thru guides into gun; continue to hold wire.

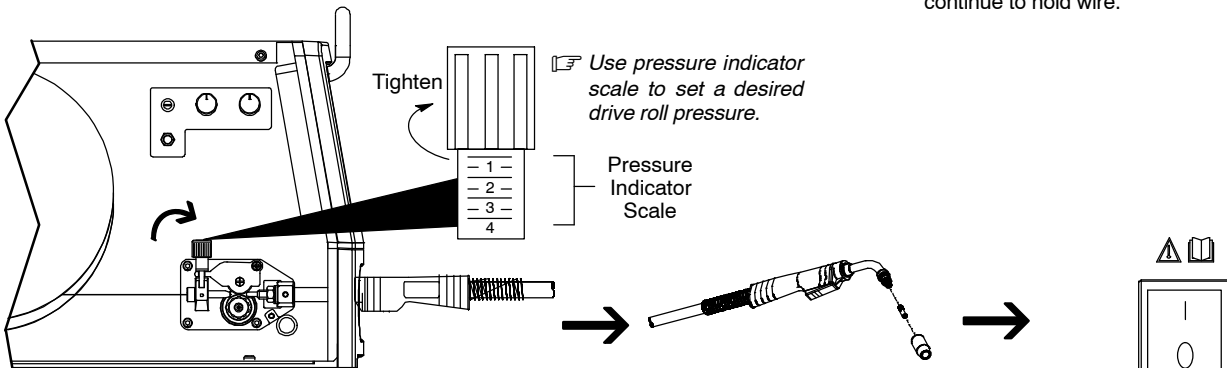

Close and tighten pressure assembly, and let go of wire.

Remove gun nozzle and contact tip.

Turn On.

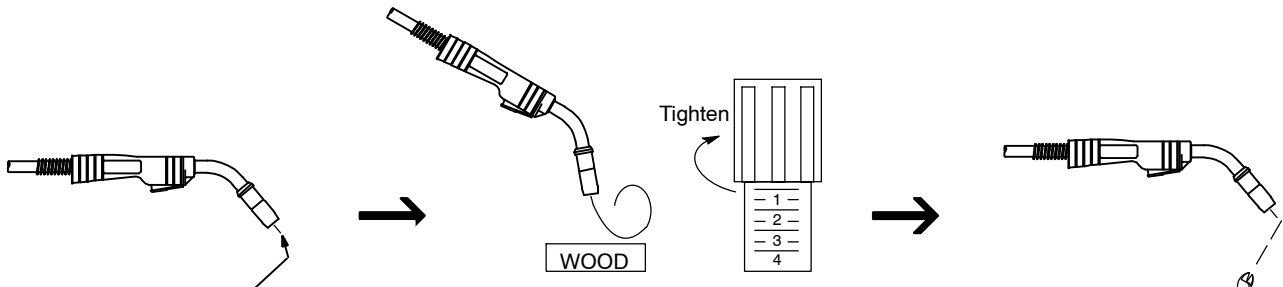

Press gun trigger until wire comes out of gun. Reinstall contact tip and nozzle

Feed wire to check drive roll pressure. Tighten knob enough to prevent slipping.

Cut off wire. Close and latch door.

956142715_3-5/956142715_4-5

SECTION 4 – OPERATION

4-1. Controls For MigMatic 220/250

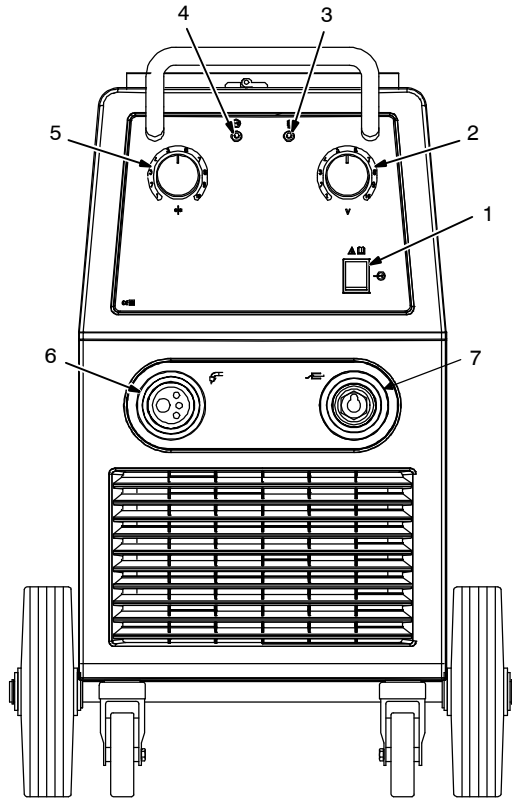
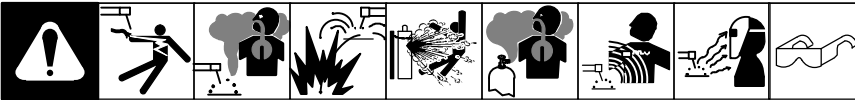

- 1 Power Switch S1
Use switch to turn power on and off.
- 2 Voltage Control S2
Turn control clockwise to increase voltage.
- 3 High Temperature Shutdown Light PL2 (Orange LED)
- 4 Power Indicator Light PL1 (White LED)
- 5 Wire Feed Speed Control R1
Turn control clockwise to increase wire feed speed.
- 6 MIG Torch Connection
Connection for Euro style MIG gun.
- 7 Work Lead Connection

956142715_5-5

4-2. Burnback And Spot Weld Timer Controls

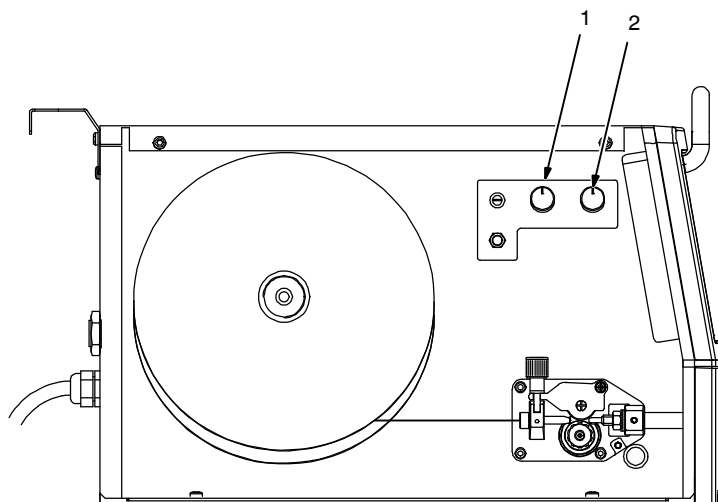
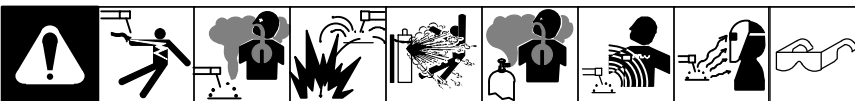

- 1 Burnback Control R3
Time that welding wire stays energized after trigger is released.
- 2 Spot Weld Timer R2
Time that welding arc is active before shutting off automatically.
Spot Timer resets after releasing gun trigger.

956142715_3-5

4-3. Controls For MigMatic 220 DX / 250 DX

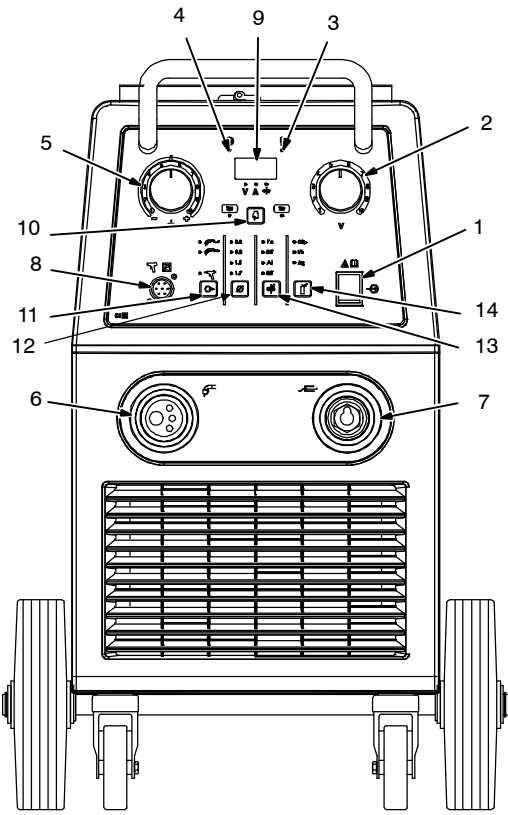
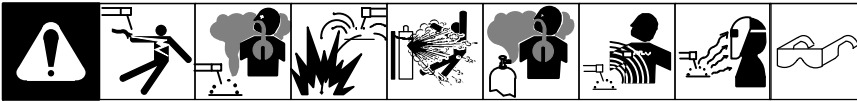

- 1 Power Switch S1
Use switch to turn power on and off.
- 2 Voltage Control S2
Turn control clockwise to increase voltage.
- 3 High Temperature Shutdown Light PL2-(Orange LED)
- 4 Power Indicator Light PL1 (White LED)
- 5 Wire Feed Speed (WFS)/Trim (Arc Length) And Line Input Adjustment Control R1 (See Section 4-5)
- 6 MIG Torch Connection
Connection for Euro style MIG gun.
- 7 Work Lead Connection
- 8 Spool Gun Connection 7-pin Plug Receptacle
- 9 Digital Display Meter
Displays values and parameters for selected welding process
- 10 Setup Button
Use button to select parameters (V, A, %), and to change from manual to synergic MIG modes.
- 11 Trigger Mode Button
Use control to select desired trigger mode (see Section 4-7).
- 12 Wire Diameter Push Button
Use control to Select desired welding wire diameter for synergic MIG process (see Section 4-9).
- 13 Material Button
Use control to select material type for synergic MIG process (see Section 4-10).
- 14 Gas Selection Button
Use control to select desired welding gas type for synergic MIG process (see Section 4-11).

956142718_5-5

4-4. Burnback And Spot Weld Timer Controls

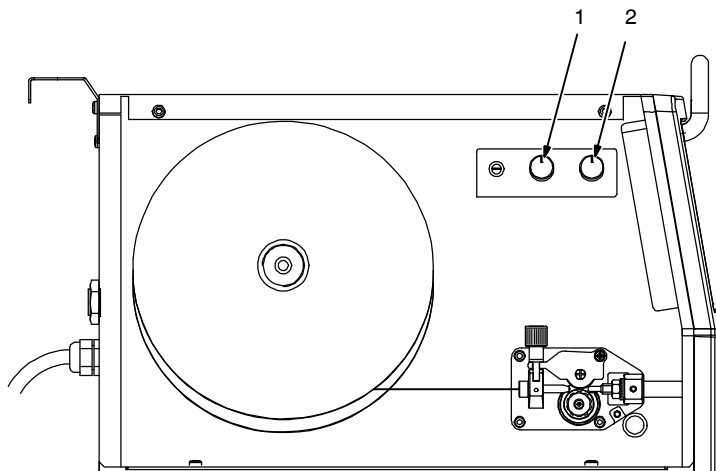
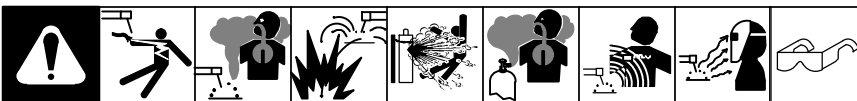

- 1 Burnback Control R3
Use control to set time welding wire stays energized after trigger is released.
- 2 Wire Run-In Speed Control R2
Use control to determine rate at which welding wire feeds before an arc is initiated.

956142718_4-5

4-5. Welding Power Source Input Line Voltage Adjustment (DX Models Only)

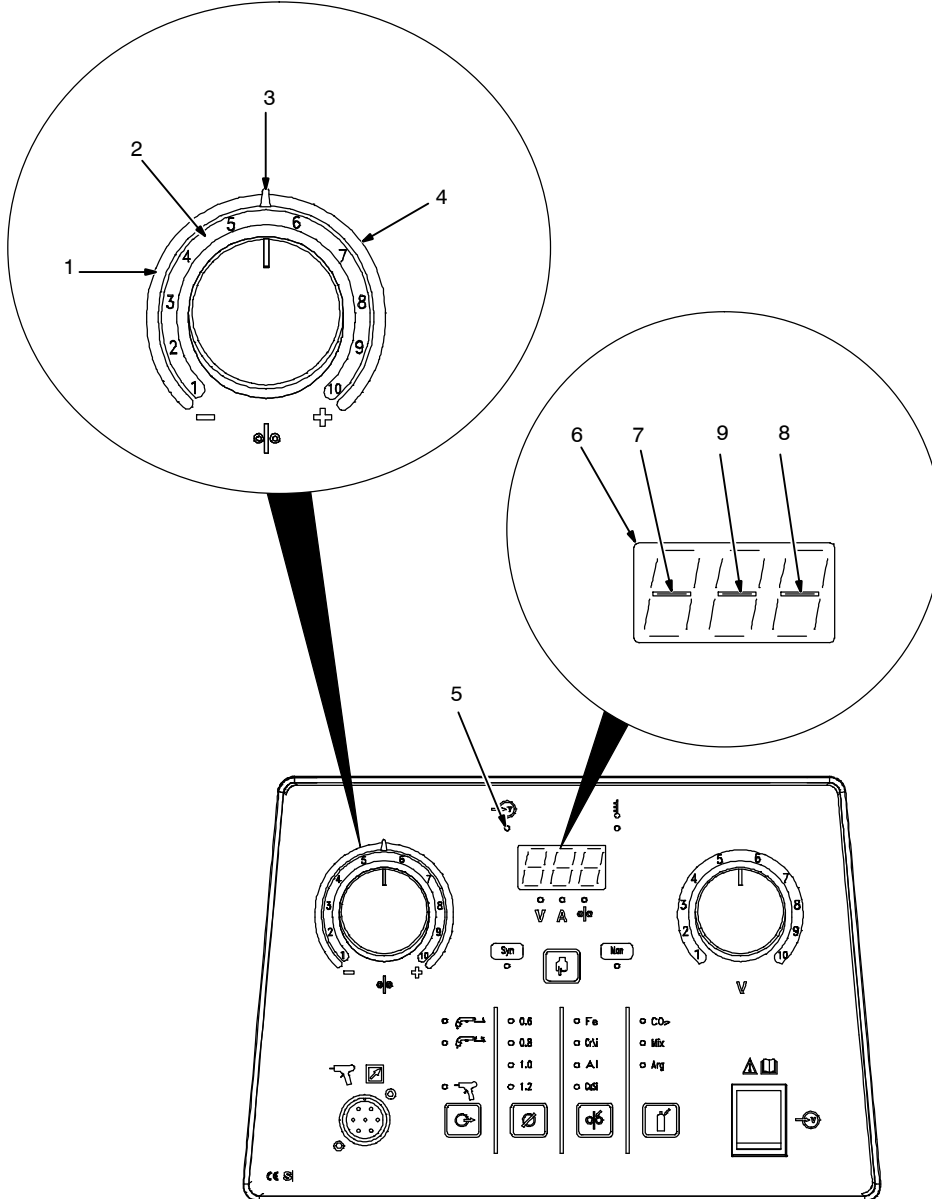
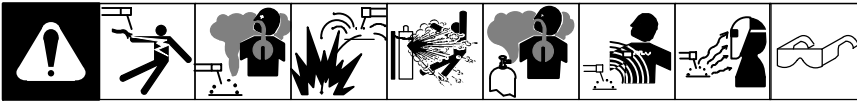

- 1 Wire Feed Speed (WFS)/Trim (Arc Length) And Line Input Adjustment Control R1
- 2 Wire Feed Speed Indicator Scale (Manual Mode)
- 3 Input Line Voltage Adjustment Center Indicator (Synergic Mode)
- 4 Input Line Voltage/Wire Speed Adjustment Indicator Scale (Synergic Mode)

Before power up, turn control R1 to the center position.

Within 5 seconds of power up, unit verifies value of input line voltage, and if necessary, makes correction based on a percentage of preset (synergic) parameters.

- 5 Power Indicator Light PL1
- 6 Digital Meter Display

The required type of input voltage correction (plus or minus) is displayed on digital meter as follows:

- 7 Negative Percentage Input Line Voltage Adjustment Display Indicator

- A dash in the left segment of the meter and a flashing PL1 indicates the need for a negative correction. Turn R1 counterclockwise to decrease value.

- 8 Positive Percentage Input Line Voltage Adjustment Display Indicator

- A dash in the right segment of the meter and a flashing PL1 indicates the need for a positive correction. Turn R1 clockwise to increase value.

- 9 Correct Input Line Voltage Display Indicator

- A dash in the center segment of the meter indicates the input voltage is correct.

Input line voltage compensations are made each time the unit is turned on.

⚠ *Fluctuations in input line voltage that occur more than five seconds after power up are not automatically compensated for. The operator must manually adjust for incorrect input line voltage by rotating control R1.*

Correct adjustment is confirmed by a beeping or buzzer signal, while a flashing power indicator light PL1 indicates an incorrect input line voltage.

⚠ *While PL1 is flashing, the machine will continue to operate, but weld output characteristics may be affected.*

After correct input line voltage has been established, 220 or 250 (depending on model) is displayed on the meter.

⚠ *Each time the machine is turned on, the last setting is displayed*

4-6. Welding Power Source Setup Menu (DX Models Only)

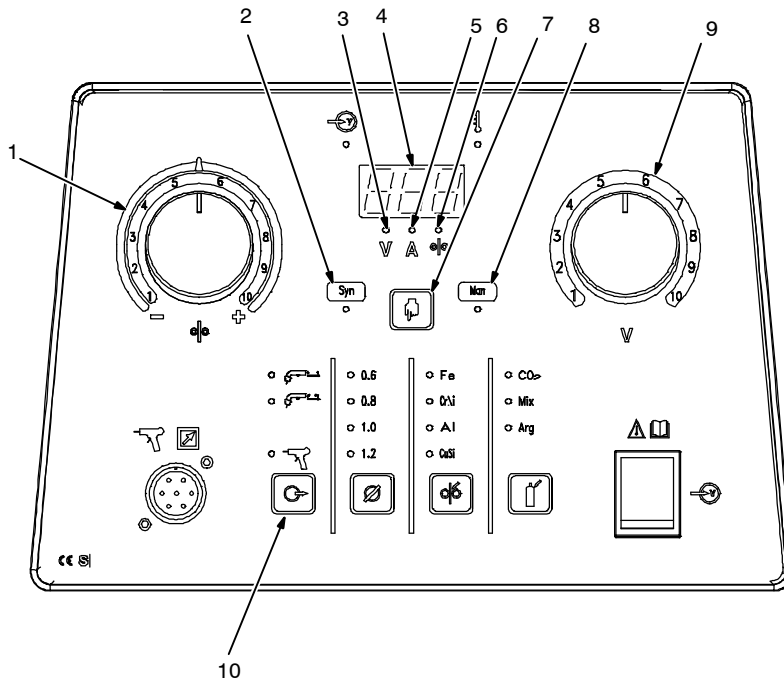
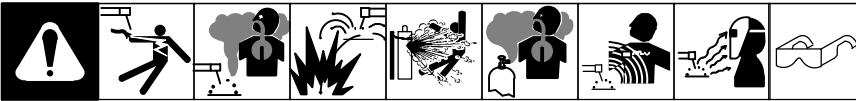

- 1 Wire Feed Speed (WFS)/Trim (Arc Length) And Line Input Adjustment Control R1
- 2 Synergic Mode Indicator
- 3 Voltage LED
- 4 Digital Display Meter
- 5 Amperage LED
- 6 Wire Feed Speed LED
- 7 Setup Button
- 8 Manual Mode Indicator
- 9 Voltage Control
- 10 Trigger Mode Button

Use setup button to select desired parameter: voltage, amperage, or preset wire feed speed and lite corresponding LED (V, A, or %).

Rotate Wire Feed Speed (WFS)/Trim (Arc Length) And Line Input Adjustment Control to change wire feed speed or amperage, depending upon which parameter is active.

Rotate voltage control to change voltage when voltage LED is lit.

The value of the selected parameter is displayed on display meter.

 The default for preset wire feed speed is meters per minute. To change to inches per minute, press and hold setup and trigger function buttons for approximately 5 seconds.

Selecting Manual Or Synergic Mode

Press and hold setup button for approximately 3 seconds to switch between manual mode (see Section 4-12) and synergic mode (see Section 4-13), and lite corresponding mode indicator LED .

4-7. Trigger Mode Selection (DX Models Only)

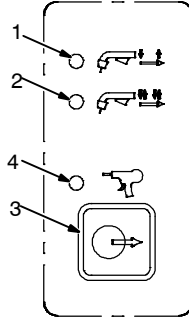
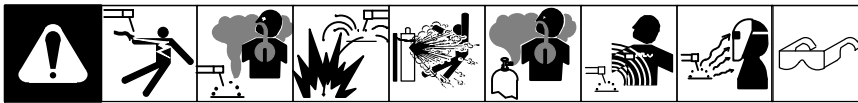

☞ Always select a trigger mode.

1 2T Trigger Mode

When trigger is pressed welding starts. When trigger is released, welding stops.

2 4T Trigger Mode

When trigger is pressed, welding starts. When trigger is released, welding continues. When trigger is pressed and released a second time, welding stops.

3 Trigger Mode Selection Button

Press button to select desired trigger mode and lite corresponding LED.

☞ 2T and 4T trigger methods work in both manual and synergic modes.

4 Spool Gun Mode (See Section 4-8)

4-8. Spool Gun Mode (DX Models Only)

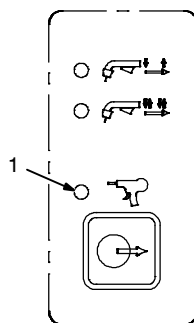
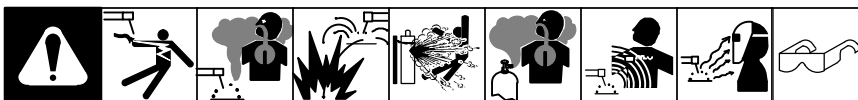

1 Spool Gun Mode Indicator LED

Connect spool gun to 7-pin spool gun receptacle (see Section 4-3).

With spool gun connected and power source in the manual mode, the manual mode indicator LED is lit (see Section 4-6), and wire feed speed is controlled with the potentiometer on the spool gun.

While in the synergic mode, the synergic mode indicator LED is lit. Use only aluminum welding wire in the synergic mode.

☞ When spool gun is connected, 2T and 4T trigger modes are disabled.

☞ For 2T and 4T trigger operation, see Section 4-7.

4-9. Welding Wire Diameter Selection For Synergic MIG (DX Models Only)

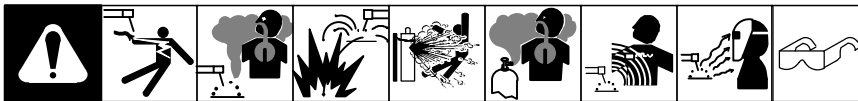

- 1 Welding Wire Diameters
- 2 Welding Wire Diameter Button

Press button to select desired wire diameter: 0.6 mm, 0.8 mm, 1.0 mm, or 1.2 mm, and lite corresponding LED.

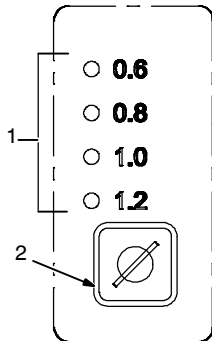

4-10. Welding Wire Type Selection For Synergic MIG (DX Models Only)

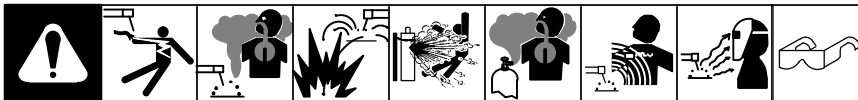

- 1 Welding Wire Types
- 2 Welding Wire Type Button

Press button to select desired wire type: Fe (ferris), CrNi (stainless steel), Al (aluminum), or CuSi (Copper Silicon), and lite corresponding LED.

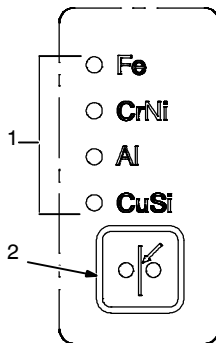

4-11. Gas Selection For Synergic MIG (DX Models Only)

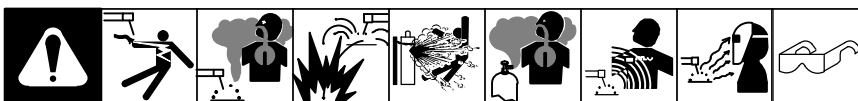

- 1 Shielding Gas Types
- 2 Gas Selection Button

Press button to select desired shielding gas type: CO₂ (Carbon Dioxide), Mix (ArCO₂), Arg (Argon), and lite corresponding LED.

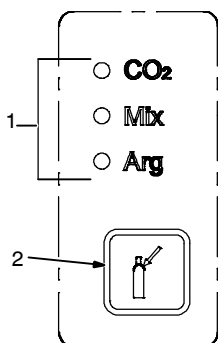

4-12. Selecting Manual MIG Welding (DX Models Only)

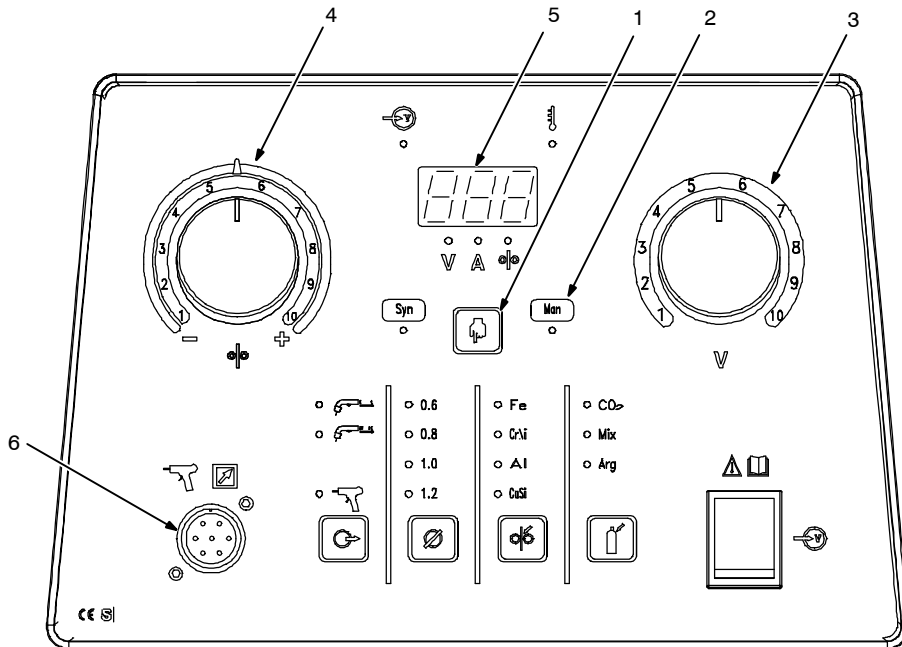
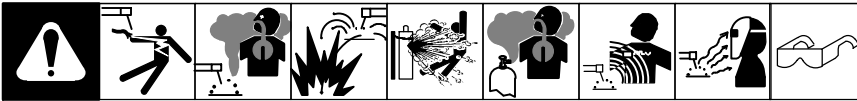

- 1 Setup Button
- 2 Manual MIG Mode Indicator

Press and hold setup button for approximately 3 seconds to select manual MIG mode and lite indicator.

- 3 Voltage Control S2
- 4 Wire Feed Speed (WFS)/Trim (Arc Length) And Line Input Adjustment Control R1
- 5 Digital Display Meter

In Manual MIG mode, the operator may need to adjust main welding parameters for specific arc characteristics

Use setup button to select desired parameter: voltage, amperage, or preset wire feed speed and lite corresponding LED (V, A, or %).

The value of the selected parameter is displayed on meter.

Turn voltage control clockwise to increase voltage.

Turn wire feed speed control clockwise to increase wire feed speed.

Select trigger mode 2T or 4T according to Section 4-7.

Spool Gun Operation:

- 6 Spool Gun Receptacle

For spool gun connection and operation, see section 4-8.

4-13. Selecting Synergic MIG Welding (DX Models Only)

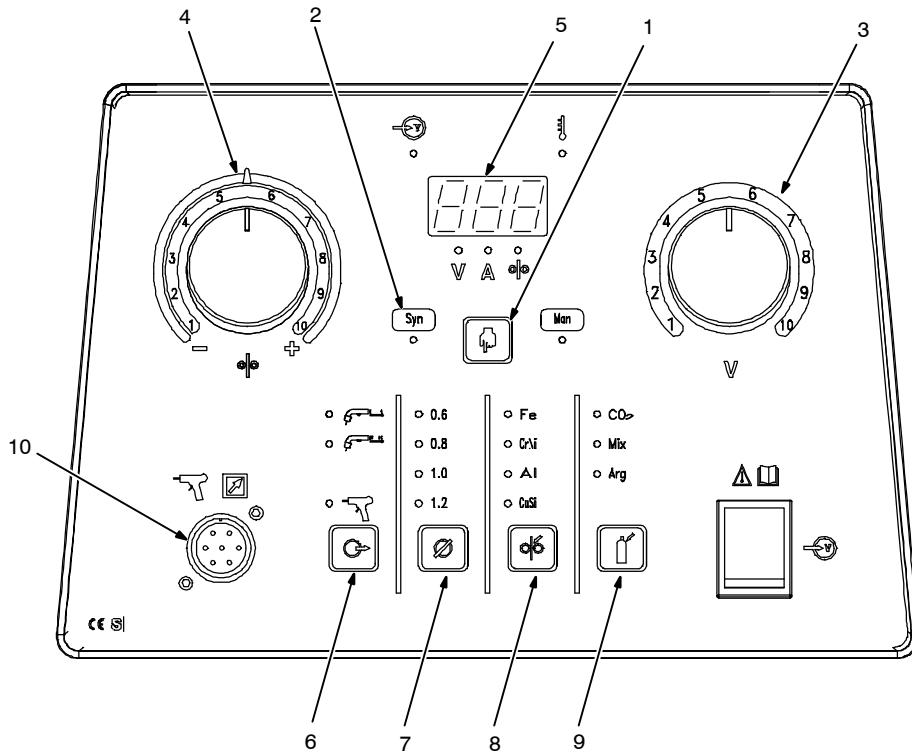
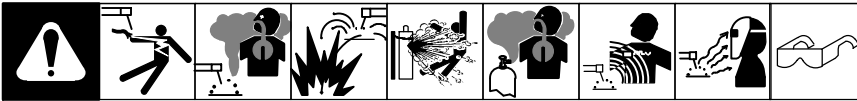

- 1 Setup Button
- 2 Synergic MIG Mode Indicator
- 3 Voltage Control S2
- 4 Wire Feed Speed (WFS)/Trim (Arc Length) And Line Input Adjustment Control R1
- 5 Digital Display Meter

In synergic MIG mode, the operator may have to adjust welding data for specific arc characteristics. Generally voltage is adjusted and the synergic process automatically sets appropriate wire feed speed.

Use setup button to select desired parameter: voltage, amperage, or preset wire feed speed and lite corresponding LED (V, A, or %).

The value of the selected parameter is displayed on meter.

Turn voltage control S2 clockwise to increase voltage.

Turn wire feed speed control R1 clockwise to increase wire feed speed.

- 6 Trigger Mode Button
- Use button to select 2T or 4T (see Section 4-7).

- 7 Wire Diameter Button
- Use button to select desired wire diameter.

- 8 Welding Wire Type Button
- Use button to select appropriate welding wire type.

- 9 Gas Selection Button
- Use button to select desired shielding gas.

Spool Gun Operation:

- 10 Spool Gun Receptacle
- For spool gun connection and operation, see section 4-8.

SECTION 5 – MAINTENANCE & TROUBLESHOOTING

5-1. Routine Maintenance

					Disconnect power before maintaining.		<i>Maintain more often during severe conditions.</i>
	3 Months	Replace unreadable labels			Repair or replace cracked weld cable		
		Clean and tighten weld terminals					
	6 Months	Blow out or vacuum inside.			Remove drive roll and carrier. Apply light coat of oil or grease to drive motor shaft.		

5-2. Circuit Breaker CB1

					<p>1 Circuit Breaker CB1 CB1 protects the unit from overloading of drive motor M1. If CB1 opens, wire feeding stops.</p> <p>2 Welding Gun Check gun liner for blockage or kinks.</p> <p>3 Wire Drive Assembly Check for jammed wire, binding drive gear or misaligned drive rolls. Allow cooling period and reset breaker. Close door.</p>

5-3. Unit Overload

Thermal switches TP1 in SR1 and TP2 in XFMR protect the unit from damage due to overheating. If the thermal indicator illuminates, wait for unit to cool allowing fan motor to run before trying to weld. If unit is cool and no weld output continues, contact Factory Authorized Service Agent.

5-4. Troubleshooting



Trouble	Remedy
No weld output; wire does not feed.	Be sure line disconnect switch is On (see Section 3-10).
	Replace building line fuse or reset circuit breaker if open (see Section 3-10).
	Reset circuit breaker CB1 (see Section 5-2).
	Secure gun trigger connections.
	Check continuity of power switch S1 and replace if necessary.
	Have Factory Authorized Service Agent check main transformer T1 for signs of winding failure. Check continuity across windings and check for proper connections. Check secondary voltages. Replace T1 if necessary.
	Have Factory Authorized Service Agent check continuity of thermostats TP1 and TP2. Replace TP1 and TP2 if necessary.
	Have Factory Authorized Service Agent check main control board PC1 and connections, and replace if necessary.
No weld output; wire feeds.	Connect work clamp to get good metal to metal contact.
	Replace contact tip (see gun Owner's Manual).
	An overload condition occurred (see Section 5-3)
	Have Factory Authorized Service Agent check diodes in main rectifier SR1, and replace if necessary.
	Have Factory Authorized Service Agent check stabilizer Z1 for signs of winding failure. Check continuity across windings and check connections. Replace Z1 if necessary.
	Have Factory Authorized Service Agent check main transformer T1 for signs of winding failure. Check continuity across windings and check connections. Check secondary voltages. Replace T1 if necessary.
	Have Factory Authorized Service Agent check voltage switch(s). Replace if necessary.
Low weld output.	Connect unit to proper input voltage or check for low line voltage (see Section 3-8).
	Check input voltage jumper links and correct position if necessary (see Section 3-8).
	Have Factory Authorized Service Agent check main rectifier SR1, and replace if necessary.
	Have Factory Authorized Service Agent check voltage switch(s). Replace if necessary.
	Adjust input line voltage (see Section 4-5).
Low, high, or erratic wire speed.	Readjust front panel settings (see Section 4-1).
	Change to correct size drive rolls.
	Readjust drive roll pressure (see Section 3-12).
	Replace inlet guide, contact tip, and/or liner if necessary.
	Check position of input jumper links (see Section 3-8).
	Have Factory Authorized Service Agent check Wire Speed control R1, and replace if necessary.
	Have Factory Authorized Service Agent check diodes in main rectifier SR1, and replace if necessary.
	Have Factory Authorized Service Agent check main control board PC1 and connections and replace if necessary.
No wire feed.	Reset circuit breaker CB1 (see Section 5-2).
	Rotate Wire Speed control R1 to higher setting (see Sections 4-1 and 4-3).
	Clear obstruction in gun contact tip or liner (see gun Owner's Manual).

SECTION 6 – ELECTRICAL DIAGRAMS

	WARNING Do not touch live electrical parts. Disconnect input power or stop engine before servicing. Do not operate with covers removed. Have only qualified persons install, use, or service this unit.
	ELECTRIC SHOCK HAZARD

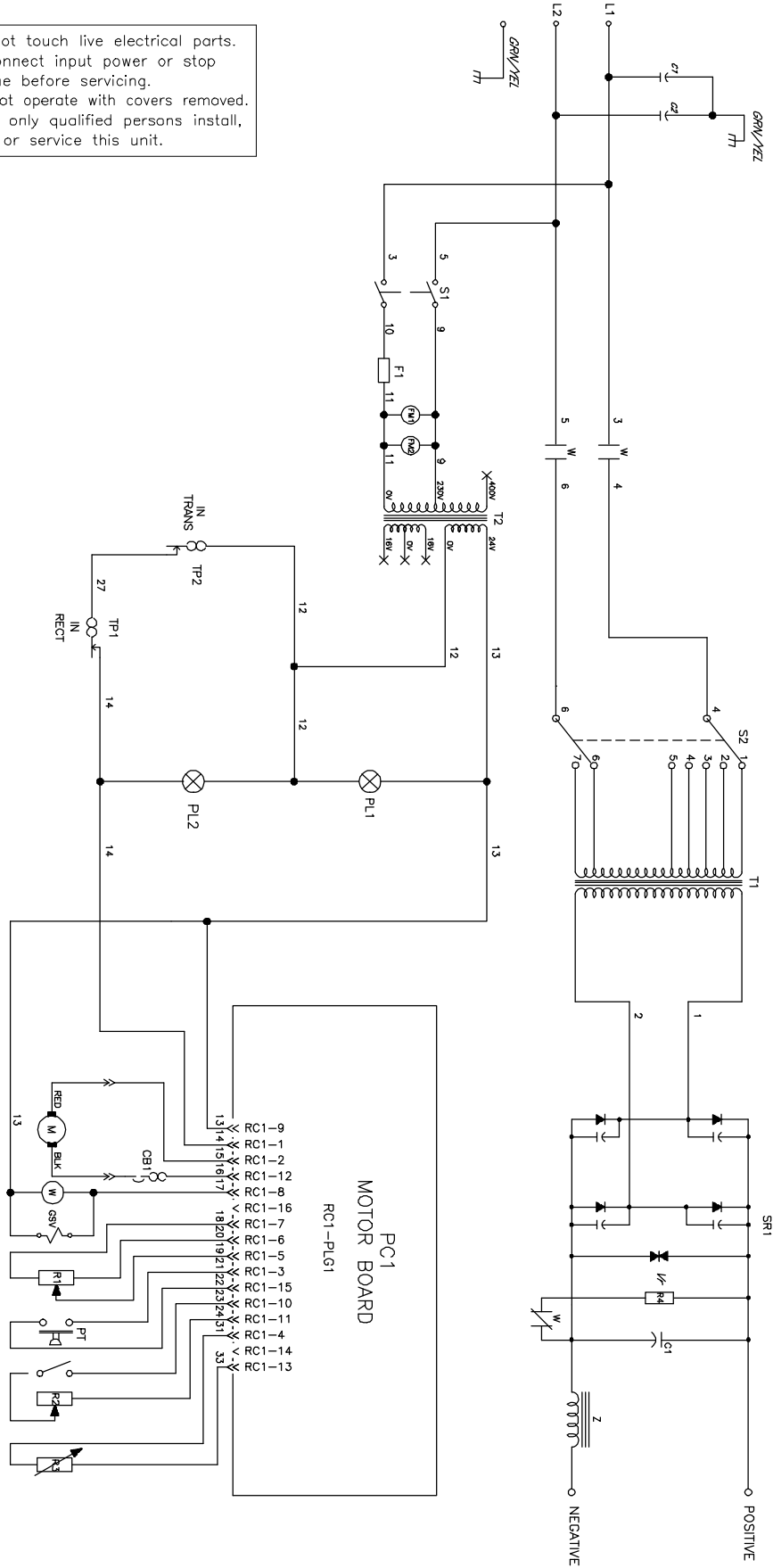



Figure 6-1. Circuit Diagram for Migmatic 220 (230 VAC)

956142709-C

 WARNING	<ul style="list-style-type: none"> Do not touch live electrical parts. Disconnect input power or stop engine before servicing. Do not operate with covers removed. Have only qualified persons install, use, or service this unit.
	
ELECTRIC SHOCK HAZARD	

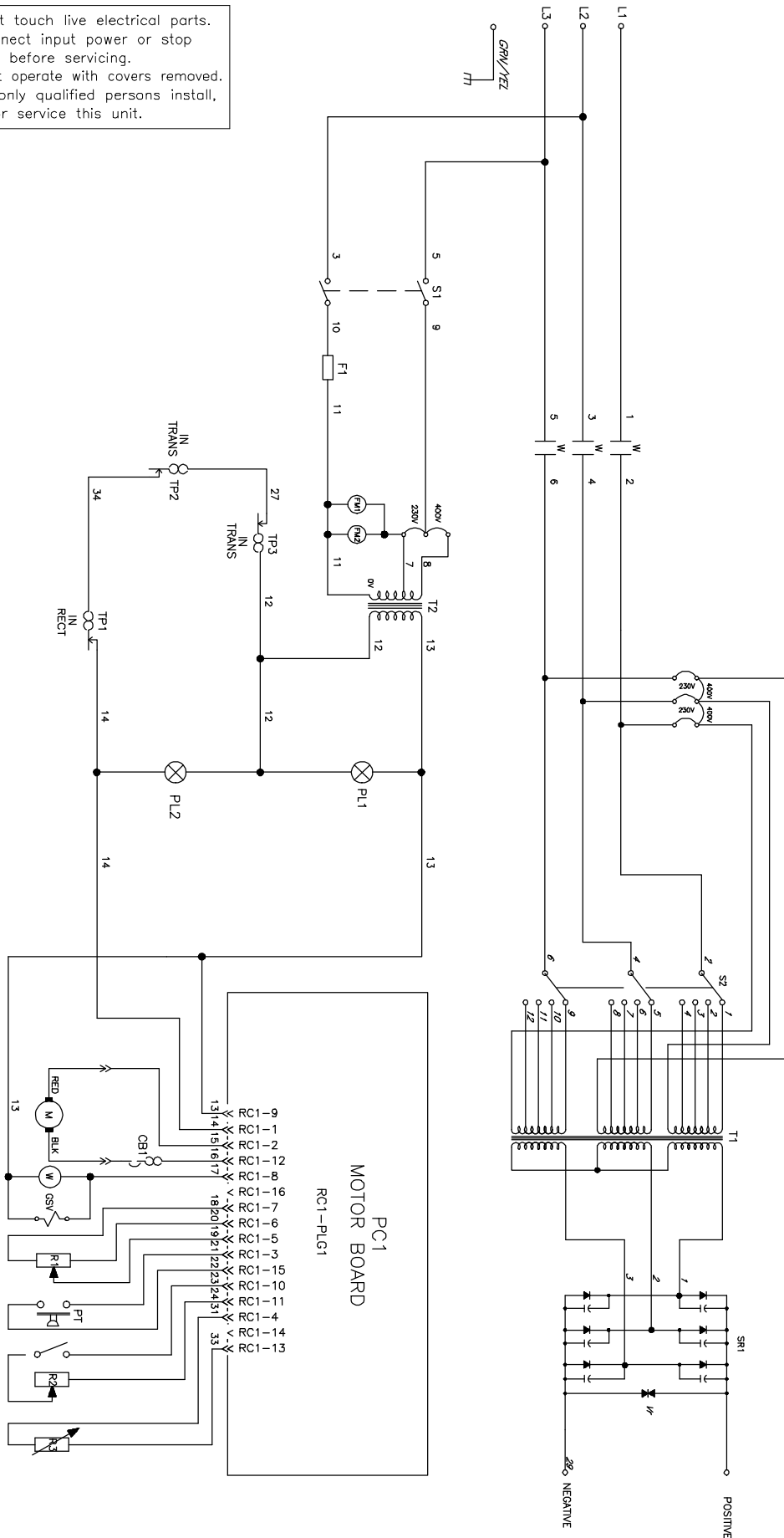



Figure 6-2. Circuit Diagram for Migmatic 250 (230/400 VAC)

 WARNING ELECTRIC SHOCK HAZARD	<ul style="list-style-type: none"> Do not touch live electrical parts. Disconnect input power or stop engine before servicing. Do not operate with covers removed. Have only qualified persons install, use, or service this unit.

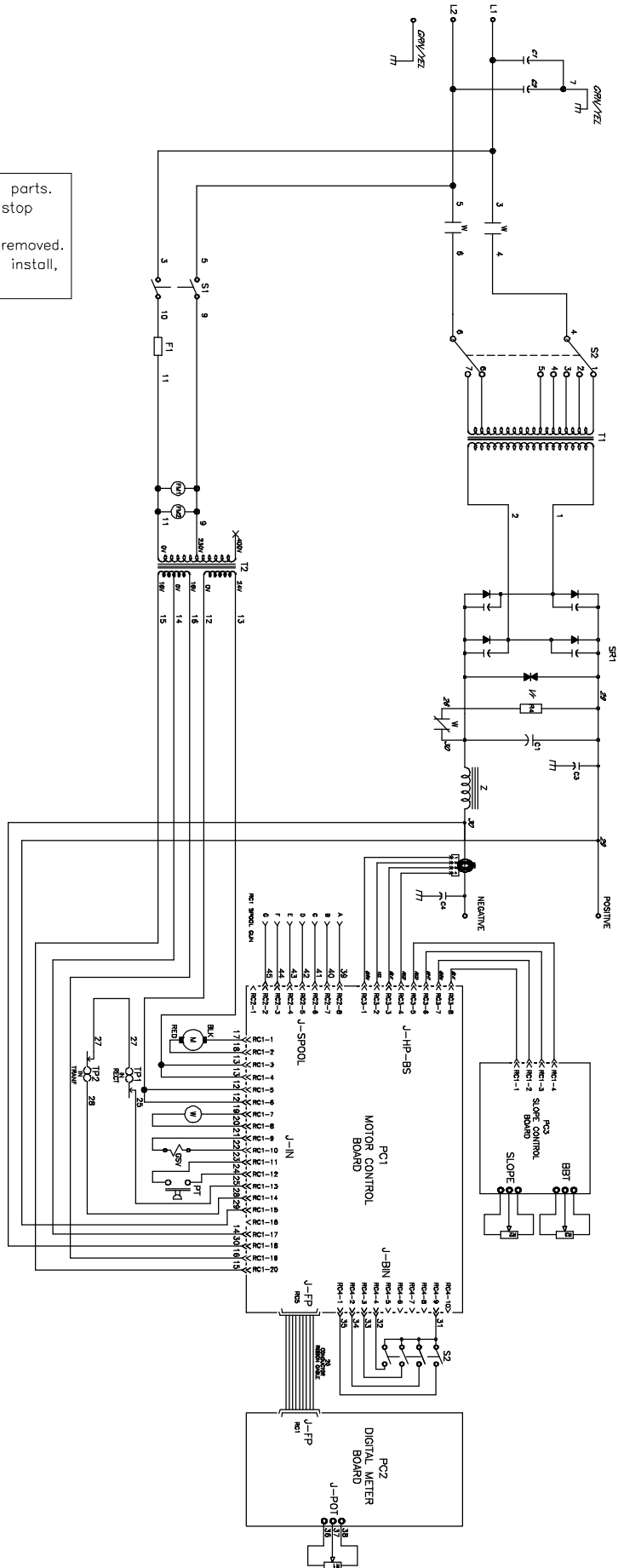



Figure 6-3. Circuit Diagram for Migmatic 220 DX (230 VAC)

 WARNING	<ul style="list-style-type: none"> Do not touch live electrical parts. Disconnect input power or stop engine before servicing. Do not operate with covers removed. Have only qualified persons install, use, or service this unit.
 ELECTRIC SHOCK HAZARD	

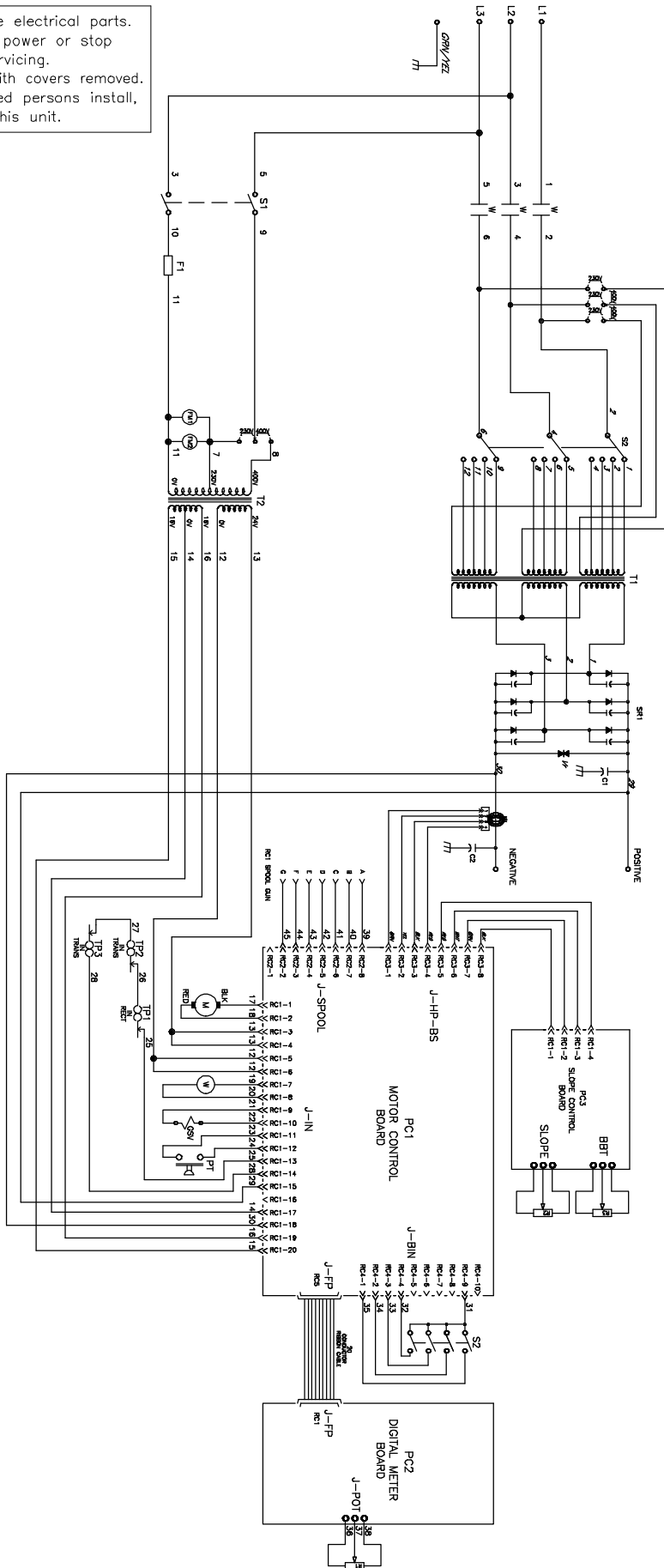
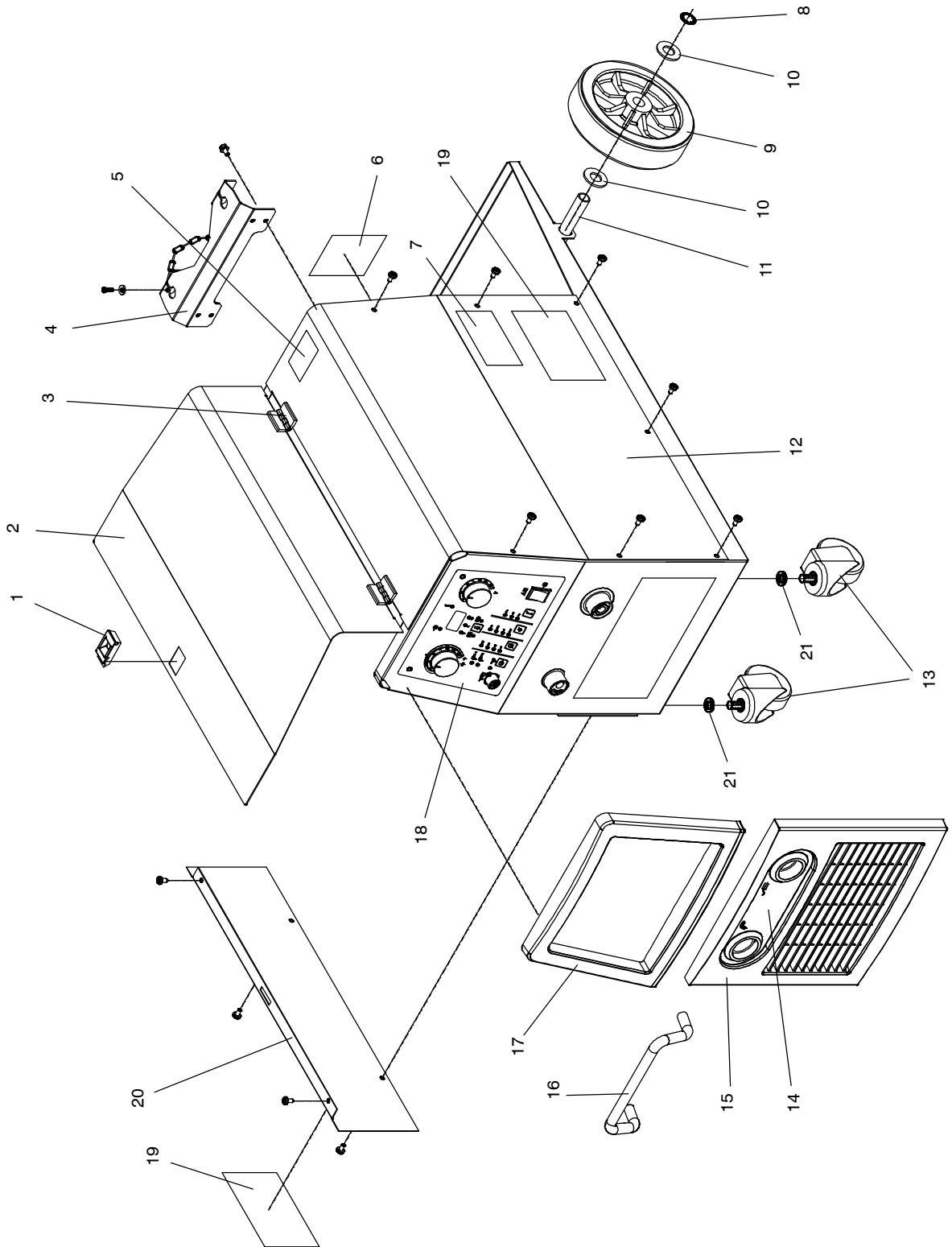

Figure 6-4. Circuit Diagram for Migmatic 250 DX (230/400 VAC)

SECTION 7 – PARTS LIST



956142718_2-5-A

Figure 7-1. Wrapper Assembly, All Models

Item No.	Part No.	Description	Quantity	
Figure 7-1. Wrapper Assembly, All Models			Base	DX
... 1	156034005	.. Catch, side panel	1	1
... 2	156007042	.. Side Panel, hinged	1	1
... 3	156034006	.. Hinge	2	2
... 4	156005145	.. Cylinder Rack, upper support	1	1
... 5	000207235	.. Label, warning, tilt	1	1
... 6	956142682	.. Rating Plate, MigMatic 220	1	1
... 6	956142684	.. Rating Plate, MigMatic 220 DX	1	1
... 6	956142683	.. Rating Plate, MigMatic 250	1	1
... 6	956142685	.. Rating Plate, MigMatic 250 DX	1	1
... 7	000207291	.. Label, primary power connections	1	1
... 8	156023157	.. Wheel, retaining clip	2	2
... 9	056 054082	.. Wheel, rear, 200 O.D	2	2
... 10	156009132	.. Washer	4	4
... 11	156012137	.. Axle, rear wheel	1	1
... 12	+156122080	.. Cover, right side	1	1
... 13	056054083	.. Wheel/Caster, front 80 O.D	2	2
... 14	356029212	.. Nameplate, lower, front, MigMatic 220/250	1	1
... 15	156118060	.. Plastic, lower, front, MigMatic 220/250	1	1
... 16	656002019	.. Handle	1	1
... 17	156118061	.. Plastic, upper, front, MigMatic 220/250	1	1
... 18	356029210	.. Nameplate, upper, front, MigMatic 220/250	1	1
... 18	356029209	.. Nameplate, upper, front, MigMatic 220 DX/250 DX	1	1
... 19	000207233	.. Label, general precautionary	2	2
... 20	+156122081	.. Side Panel, left side, lower	1	1
... 21	156009137	.. Washer, D. 12 x 36	2	2

+When ordering a component originally displaying a precautionary label, the label should also be ordered.

To maintain the factory original performance of your equipment, use only Manufacturer's Suggested Replacement Parts. Model and serial number required when ordering parts from your local distributor.

Item No.	Dia. Mkgs.	Part No.	Description	Quantity
----------	------------	----------	-------------	----------

Figure 7-2. Main Assembly for MigMatic 220

...	1	156 012 138	.. Spool Holder, shaft	1
...	2	656 009 004	.. Washer, 17x70, plastic	1
...	3	656 102 007	.. Hub	1
...	4	156 009 134	.. Washer , flat	1
...	5	156 032 136	.. Spring, 17x3x6 L.40	1
...	6	056 020 072	.. Handwheel Reel, W/Ring	1
...	7	156 015 027	.. Spool Nut, plastic	1
...	8	F1 *056 092 097	.. Fuse, 2A 5 0 0 V	1
...	9	000 207 076	.. Knob, pointer, d.22	2
...	10	356 029 214	.. Nameplate, inner, MigMatic 220/250	1
...	11	156 008 040	.. Spacer, wire feeder, plastic	1
...	12	057 021 023	.. Wire Drive System, 2 roll, d.48	1
...	13	556 090 042	.. Wire Guide, outlet	1
...	14	057 052 047	.. Connector, minieuro, quick female	1
...	15	956 142 714	.. Label, box consumable	1
...	16	116 039 030	.. Box Protection, pcb	1
...	17	S2 056 067 266	.. Switch, 25A 10 pos	1
...	18	R1 056 059 284	.. Potentiometer, 1Kohms, linear, straight pins	1
...	19	PL1 056 072 079	.. Pilot, 24V lamp, white	1
...	20	PL2 056 072 080	.. Pilot, 24V lamp, orange	1
...	21	000 207 075	.. Knob, pointer, d.6	1
...	22	056 020 069	.. Knob, pointer, d.7	1
...	23	156 118 062	.. Panel, front	1
...	24	S1 056 067 267	.. Switch, primary power on/off	1
...	25	056 076 260	.. Dinse Socket, female, 50 mmq.	1
...	26	T1 058 021 146	.. Transformer, 230V, 60x80 Al.	1
...	27	Z 057 098 018	.. Choke, 230V, D.7, 340x60 Al.	1
...	28	R4 056 059 285	.. Resistance, 3ohms, D.16 L90.	1
...	29	000 178 937	.. Label, warning electric shock	1
...	30	+156 122 082	.. Plate, baffle	1
...	31	SR1 056 050 156	.. Rectifier, PMS 20/4/2F	1
...	32	TP1 056 159 028	.. Thermostat, 100 ° 10A	1
...	33	656 026 123	.. Hose, gas, braided, black, D. 5x8, 10 bar	1
...	34	156 005 146	.. Corner Seal, plastic, r. 15	2
...	35	R2 056 059 286	.. Potentiometer, 100 Kohms, W/Switch straight pins	1
...	36	R3 056 059 287	.. Potentiometer, 10 Kohms, linear, straight pins	1
...	37	056 092 098	.. Fuse Holder, 6.3A 2 5 0 V	1
...	38	CB1 056 067 268	.. Circuit Breaker, 4A	1
...	39	PC1 057 084 142	.. Circuit Board, control	1
...	40	T2 058 021 147	.. Transformer, auxiliary	1
...	41	C1 056 082 100	.. Capacitor, 22000MF 63V	3
...	42	056 070 041	.. Auxiliary Contacts, BL/X2 N C	1
...	43	W 057 079 036	.. Contactor, 24V 16A 4NA CN-1 6	1
...	44	156 005 147	.. Plate, support, black	1
...	45	000 155 436	.. Label, ground	2
...	46	156 118 063	.. Base	1
...	47	FM 057 035 019	.. Motor, fan	2
...	48	156 118 065	.. Panel, rear	1
...	49	000 176 106	.. Label, fan	1
...	50	GSV 056 061 068	.. Solenoid, gas valve, 24VAC	1
...	51	356 029 215	.. Nameplate, rear, input gas, MigMatic 220/250	1
...	52	220 805	.. Nut, plastic	1
...	53	656 089 041	.. Clamp	1
...	54	256 071 010	.. Line Cable, neoprene, mt 3x4.	1

+When ordering a component originally displaying a precautionary label, the label should also be ordered.

*Recommended Spare Parts.

To maintain the factory original performance of your equipment, use only Manufacturer's Suggested Replacement Parts. Model and serial number required when ordering parts from your local distributor.

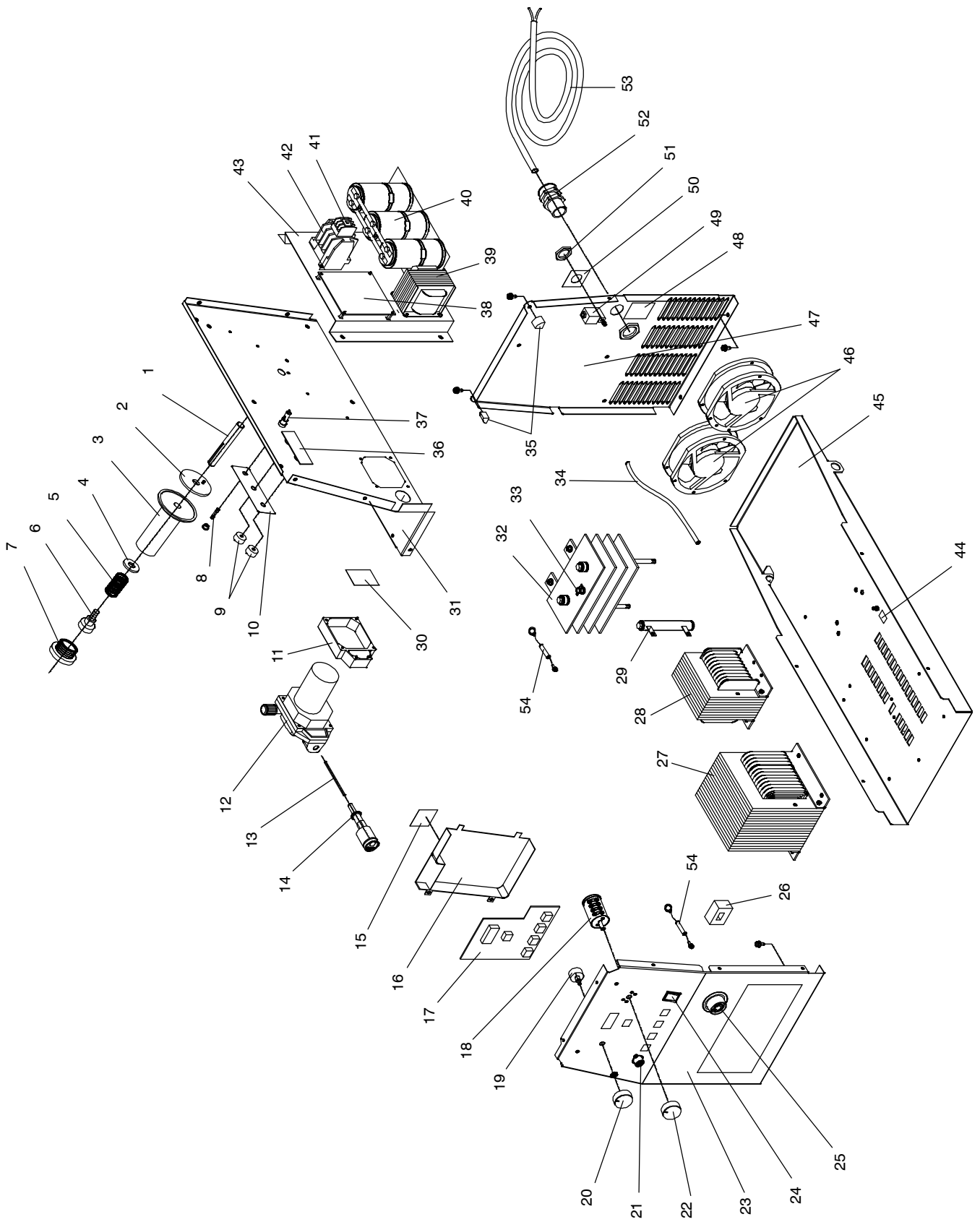

956142719-A

Figure 7-3. Main Assembly for MigMatic 220 DX

Item No.	Dia. Mkgs.	Part No.	Description	
1		156 012 138	Spool Holder, shaft	1
2		656 009 004	Washer, 17x70, plastic	1
3		656 102 007	Hub	1
4		156 009 134	Washer, flat	1
5		156 032 136	Spring, 17x3x6 L.40	1
6		056 020 072	Handwheel Reel, W/Ring	1
7		156 015 027	Spool Nut, plastic	1
8	F1	*056 092 097	Fuse, 2A 5 0 0 V	1
9		000 207 076	Knob, pointer, d.22	2
10		356 029 213	Nameplate, inner, MigMatic 250 DX	1
11		156 008 040	Spacer, wire feeder, plastic	1
12		057 021 023	Wire Drive System, 2 roll, d.48	1
13		556 090 042	Wire Guide, outlet	1
14		057 052 047	Connector, minieuro, quick female	1
15		956 142 714	Label, box consumable	1
16		116 039 030	Box Protection, pcb	1
17	PC2	057 084 143	Circuit Board, digital volt/amp/wire speed display	1
18	S2	056 067 270	Switch, 25A 10 pos	1
19	R1	056 059 284	Potentiometer, 1 Kohms, linear, straight pins	1
20		000 207 075	Knob, pointer, d. 6	1
21	RC1	056 076 261	Receptacle, 7pin, spool gun	1
22		056 020 069	Knob, pointer, d. 7	1
23		156 118 066	Panel, front	1
24	S1	056 067 267	Switch, primary power on/off	1
25		056 076 260	Dinse Socket, female, 50 mmq.	1
26	HD1	056 167 007	Transducer, current 400A, module supply V+/-1 2	1
27	T1	058 021 146	Transformer, 230V, 60x80 Al.	1
28	Z	057 098 018	Choke, 230V, D.7, 340x60 Al.	1
29	R4	056 059 285	Resistance, 3ohms, D.16 L 9 0.	1
30		000 178 937	Label, warning electric shock	1
31		+156 122 082	Plate, baffle	1
32	SR1	056 050 156	Rectifier, PMS 20/4/2F	1
33	TP1	056 159 028	Thermostat, 100° 1 0 A	1
34		656 026 123	Hose, gas, braided, black, D. 5x8, 10 bar	1
35		156 005 146	Corner Seal, plastic, r. 15	2
36	PC3	057 084 144	Circuit Board, Burn Back Time slope adjustment	1
37		056 092 098	Fuse Holder, 6.3A 2 5 0 V	1
38	PC1	057 084 145	Circuit Board, control	1
39	T2	058 021 147	Transformer, auxiliary	1
40	C1	056 082 100	Capacitor, 22000MF 63V	3
41		056 070 041	Auxiliary Contacts, BL/X2 N C	1
42	W	057 079 036	Contact, 24V 16A 4NA CN-1 6	1
43		156 005 147	Plate, support, black	1
44		000 155 436	Label, ground	2
45		156 118 063	Base	1
46	FM	057 035 019	Motor, fan	2
47		156 118 065	Panel, rear	1
48		000 176 106	Label, fan	1
49	GSV	056 061 068	Solenoid, gas valve, 24VAC	1
50		356 029 215	Nameplate, rear, input gas, MigMatic 220/250	1
51		220 805	Nut, plastic	1
52		656 089 041	Clamp	1
53		256 071 010	Line Cable, neoprene, mt 3x4.	1
54	C3, C4	056 082 102	Capacitor, MPW 0,1MF 10% 1000VCC	2

+When ordering a component originally displaying a precautionary label, the label should also be ordered.

*Recommended Spare Parts.

To maintain the factory original performance of your equipment, use only Manufacturer's Suggested Replacement Parts. Model and serial number required when ordering parts from your local distributor.

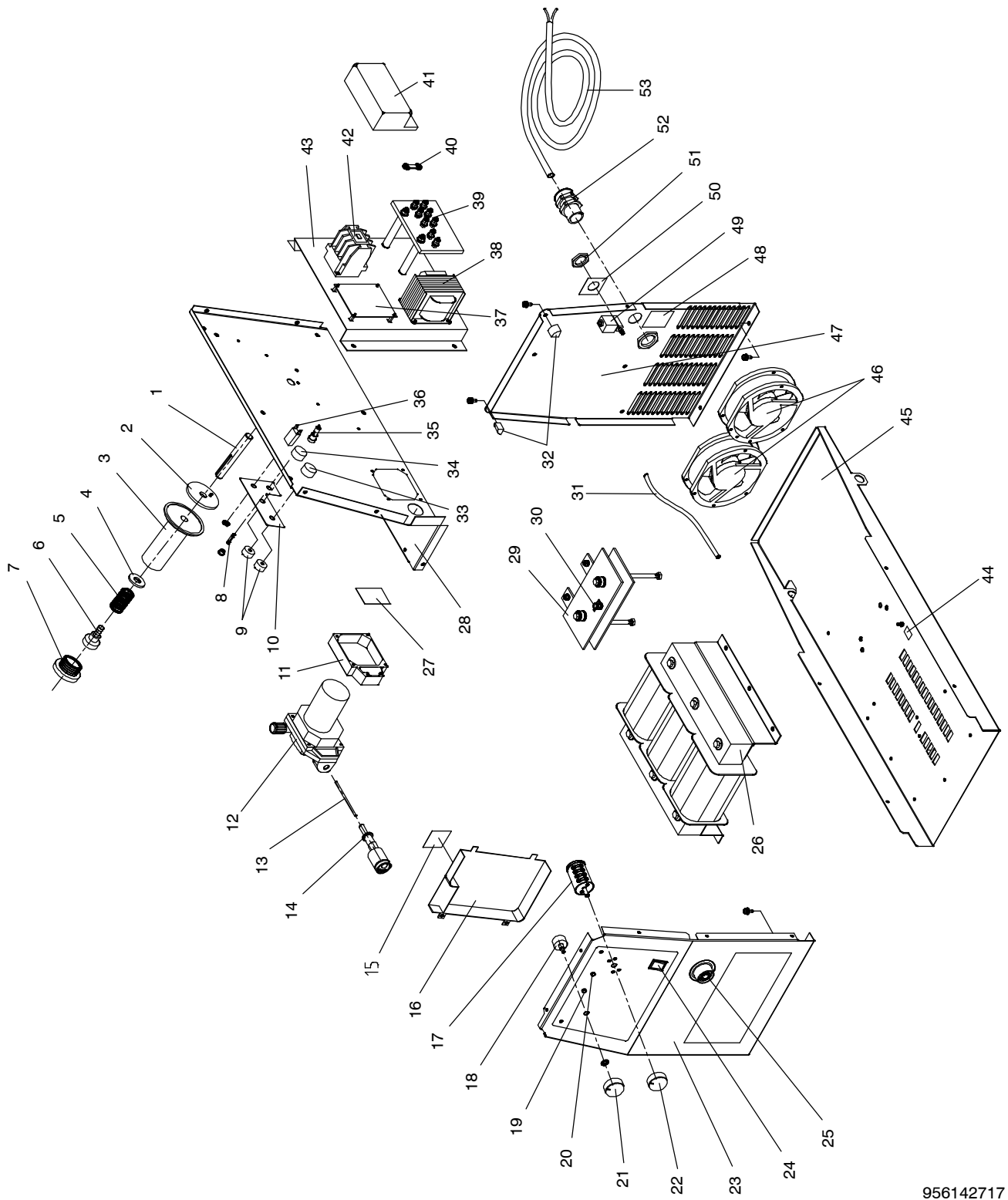

956142717

Figure 7-4. Main Assembly for MigMatic 250

Item No.	Dia. Mkgs.	Part No.	Description	
1		156 012 138	Spool Holder, shaft	1
2		656 009 004	Washer, 17x70, plastic	1
3		656 102 007	Hub	1
4		156 009 134	Washer, flat	1
5		156 032 136	Spring, 17x3x6 L.40	1
6		056 020 072	Handwheel Reel, W/Ring	1
7		156 015 027	Spool Nut, plastic	1
8	F1	*056 092 097	Fuse, 2A 500V	1
9		000 207 076	Knob, pointer, d.22	2
10		356 029 214	Nameplate, inner, MigMatic 220/250	1
11		156 008 040	Spacer, wire feeder, plastic	1
12		057 021 023	Wire Drive System, 2 roll, d.48	1
13		556 090 042	Wire Guide, outlet	1
14		057 052 047	Connector, minieuro, quick female	1
15		956 142 714	Label, box consumable	1
16		116 039 030	Box Protection, pcb	1
17	S2	056 067 269	Switch, 20A SCH 9813	1
18	R1	056 059 284	Potentiometer, 1Kohms, linear, straight pins	1
19	PL1	056 072 079	Pilot, 24V lamp, white	1
20	PL2	056 072 080	Pilot, 24V lamp, orange	1
21		000 207 075	Knob, pointer, d.6	1
22		056 020 069	Knob, pointer, d.7	1
23		156 118 062	Panel, front	1
24	S1	056 067 267	Switch, primary power on/off	1
25		056 076 260	Dinse Socket, female, 50 mmq.	1
26	T1	058 021 148	Transformer, 3ph 230/400V, 60x60x150 Al.	1
27		000 178 937	Label, warning electric shock	1
28		+156 122 082	Plate, baffle	1
29	SR1	056 050 157	Rectifier, PTS 24/3/2F	1
30	TP1	056 059 288	Thermostat, 100 °	1
31		656 026 123	Hose, gas, braided, black, D. 5x8, 10 bar	1
32		156 005 146	Corner Seal, plastic, r. 15	2
33	R2	056 059 286	Potentiometer, 100 Kohms, W/Switch straight pins	1
34	R3	056 059 287	Potentiometer, 10 Kohms, linear, straight pins	1
35		056 092 098	Fuse Holder, 6.3A 250V	1
36	CB1	056 067 268	Circuit Breaker, 4A	1
37	PC1	057 084 142	Circuit Board, control	1
38	T2	058 021 147	Transformer, auxiliary	1
39		057 024 026	Primary Power Terminal Board	1
40		556 070 017	Link, primary power terminal board	4
41		116 014 052	Protection, primary power terminal board	1
42	W	057 079 036	Contact, 24V 16A 4NA CN-1 6	1
43		156 005 147	Plate, support, black	1
44		000 155 436	Label, ground	2
45		156 118 063	Base	1
46	FM	057 035 019	Motor, fan	2
47		156 118 065	Panel, rear	1
48		000 176 106	Label, fan	1
49	GSV	056 061 068	Solenoid, gas valve, 24VAC	1
50		356 029 215	Nameplate, rear, input gas, MigMatic 220/250	1
51		220 805	Nut, plastic	1
52		656 089 041	Clamp	1
53		256 071 011	Line Cable, neoprene, mt 4x2,5.	1

+When ordering a component originally displaying a precautionary label, the label should also be ordered.

*Recommended Spare Parts.

To maintain the factory original performance of your equipment, use only Manufacturer's Suggested Replacement Parts. Model and serial number required when ordering parts from your local distributor.

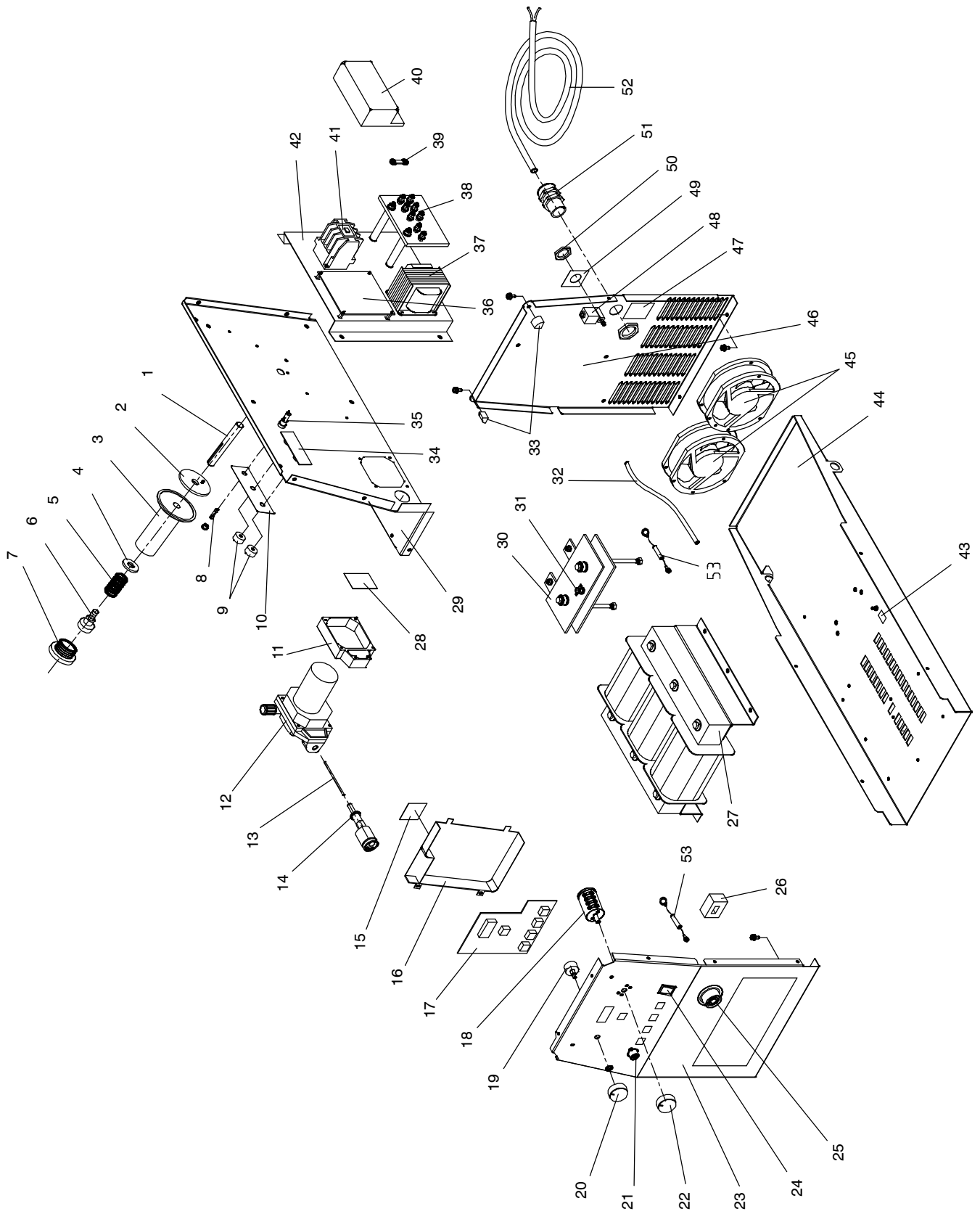

956142720-A

Figure 7-5. Main Assembly for MigMatic 250 DX

Item No.	Dia. Mkgs.	Part No.	Description
----------	------------	----------	-------------

Figure 7-5. Main Assembly for MigMatic 250 DX

1		156 012 138	.. Spool Holder, shaft	1
2		656 009 004	.. Washer, 17x70, plastic	1
3		656 102 007	.. Hub	1
4		156 009 134	.. Washer , flat	1
5		156 032 136	.. Spring, 17x3x6 L.40	1
6		056 020 072	.. Handwheel Reel, W/Ring	1
7		156 015 027	.. Spool Nut, plastic	1
8	F1	*056 092 097	.. Fuse, 2A 5 0 0 V	1
9		000 207 076	.. Knob, pointer, d.22	2
10		356 029 213	.. Nameplate, inner, MigMatic 250 DX	1
11		156 008 040	.. Spacer, wire feeder, plastic	1
12		057 021 023	.. Wire Drive System, 2 roll, d.48	1
13		556 090 042	.. Wire Guide, outlet	1
14		057 052 047	.. Connector, minieuro, quick female	1
15		956 142 714	.. Label, box consumable	1
16		116 039 030	.. Box Protection, pcb	1
17	PC2	057 084 143	.. Circuit Board, digital volt/amp/wire feed display	1
18	S2	056 067 271	.. Switch, 20A 10 pos.	1
19	R1	056 059 284	.. Potentiometer, 1 Kohms, linear, straight pins	1
20		000 207 075	.. Knob, pointer, d.6	1
21	RC1	056 076 261	.. Receptacle, 7pin, spool gun	1
22		056 020 069	.. Knob, pointer, d.7	1
23		156 118 066	.. Panel, front	1
24	S1	056 067 267	.. Switch, primary power on/off	1
25		056 076 260	.. Dinse Socket, female, 50 mmq.	1
26	HD1	056 167 007	.. Transducer, current 400A, module supply V+/-12	1
27	T1	058 021 148	.. Transformer, 3ph 230/400V, 60x60x150 Al.	1
28		000 178 937	.. Label, warning electric shock	1
29		+156 122 082	.. Plate, baffle	1
30	SR1	056 050 157	.. Rectifier, PTS 24/3/2F	1
31	TP1	056 059 288	.. Thermostat, 100 °	1
32		656 026 123	.. Hose, gas, braided, black, D. 5x8, 10 bar	1
33		156 005 146	.. Corner Seal, plastic, r. 15	2
34	PC3	057 084 144	.. Circuit Board, Burn Back Time slope adjustment	1
35		056 092 098	.. Fuse Holder, 6.3A 2 5 0 V	1
36	PC1	057 084 146	.. Circuit Board, control	1
37	T2	058 021 147	.. Transformer, auxiliary	1
38		057 024 026	.. Primary Power Terminal Board	1
39		556 070 017	.. Link, primary power terminal board	4
40		116 014 052	.. Protection, primary power terminal board	1
41	W	057 079 036	.. Contactor, 24V 16A 4NA CN-1 6	1
42		156 005 147	.. Plate, support, black	1
43		000 155 436	.. Label, ground	2
44		156 118 063	.. Base	1
45		057 035 019	.. Motor, fan	2
46		156 118 065	.. Panel, rear	1
47		000 176 106	.. Label, fan	1
48	GSV	056 061 068	.. Solenoid, gas valve, 24VAC	1
49		356 029 215	.. Nameplate, rear, input gas, MigMatic 220/250	1
50		220 805	.. Nut, plastic	1
51		656 089 041	.. Clamp	1
52		256 071 011	.. Line Cable, neoprene, mt 4x2,5.	1
53	C1, C2	056 082 102	.. Capacitor, MPW 0,1MF 10% 1000VCC	2

+When ordering a component originally displaying a precautionary label, the label should also be ordered.

*Recommended Spare Parts.

To maintain the factory original performance of your equipment, use only Manufacturer's Suggested Replacement Parts. Model and serial number required when ordering parts from your local distributor.

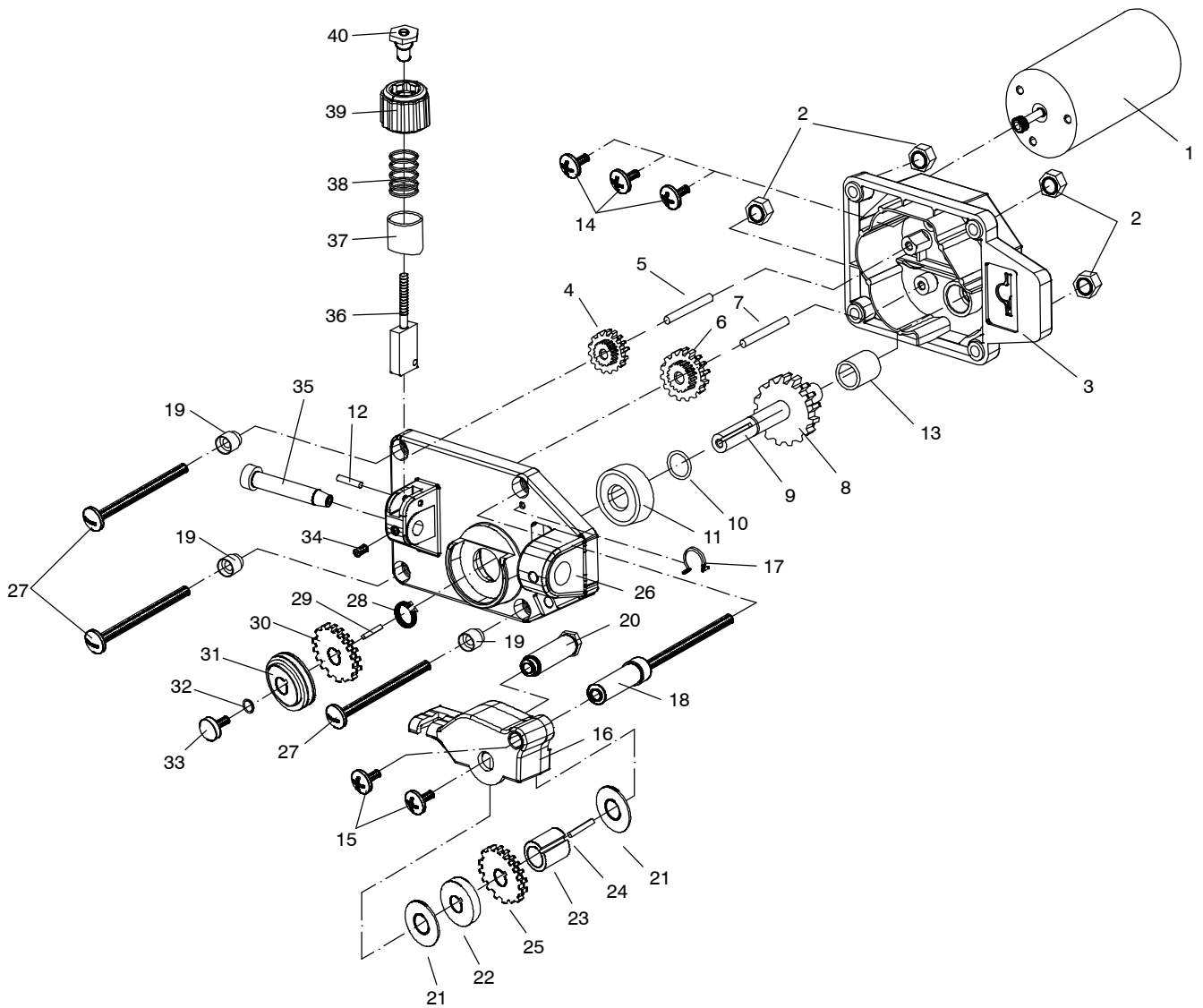

956142721

Figure 7-6. Drive Assembly, Wire (2 Roll)

Item No.	Dia. Mkgs.	Part No.	Description	Quantity
Figure 7-6. Drive Assembly, Wire (2 Roll)				
1		056126079	.. Motor, 24VDC, 60W, 5300 rpm	1
2		156018121	.. Nut, hex M5, Steel	4
3		556075032	.. Cover, rear, gear box assembly	1
4		156003034	.. Gear, reducer	1
5		156012140	.. Pin, d. 4x35	1
6		156003035	.. Gear, reducer	1
7		156012142	.. Gear/Shaft, Nylon	1
8		656003014	.. Drive shaft, central gear/drive roll	1
9		156012141	.. Snap Ring, 10x16x0,5	1
10		156023164	.. Snap Ring, 10x16x1,0	1
11		156017161	.. Bearing, d. 10x26	1
12		156012143	.. Pin, d. 3x13, knurled	1
13		156033035	.. Bushing, d.10x14, brass	1
14		156019776	.. Screw, M4x10, zinc steel	3
15		156019777	.. Screw, M4x8, pan head	2
16		056002016	.. Upper Pressure Arm Housing, die cast	1
17		156032132	.. Spring, upper pressure arm housing	1
18		156012144	.. Bushing, Upper pressure arm pivot	1
19		756009061	.. Washer, insulator drive assembly through bolt	4
20		156012145	.. Pin, drive roll	1
21		156009136	.. Washer, d. 10,5x4, brass	2
22		156053112	.. Drive Roll, upper pressure arm housing, d. 17x30	1
23		156033036	.. Bushing, upper drive roll assembly	1
24		156013050	.. Key, upper drive roll assembly, 3x3 L=15	1
25		156003036	.. Gear, upper drive roll assembly, d.17x32,5	1
26		356052008	.. Housing, Adapter Gun/Feeder	1
27		156019778	.. Bolt, M5x50, through housing	3
28		156023165	.. C clip, gear/shaft, d.10	1
29		156013051	.. Key, lower drive roll assembly, d. 3x3 L=20	1
30		156003037	.. Gear, lower drive roll assembly, d.10x32,5, drive roll	1
31		156053109	.. Wire drive Roll, d.30, see fig.7-6 referring to a table 7-1	1
32		656021268	.. O-Ring, d. 7,2x1,78	1
33		656033010	.. Thumb screw, drive roll locator, d. M4x8	1
34		156019779	.. Screw, M4x4, wire inlet	1
35		*156090022	.. Wire Inlet Guide, see fig.7-6 referring to a table 7-1	1
36		656064003	.. Tension Arm threaded assembly, pinned	1
37		156032133	.. Sleeve, d. 6x6, spring housing	1
38		156032134	.. Spring, wire tensioning	1
39		056020075	.. Knob, Adjustment tension	1
40		656033 009	.. Nut, locating, tension knob	1

To maintain the factory original performance of your equipment, use only Manufacturer's Suggested Replacement Parts. Model and serial number required when ordering parts from your local distributor.

Table 7-1. Drive Roll And Wire Guide Kits (2 Roll Models)

NOTE



Base selection of drive rolls upon the following recommended usages:

1. *V-Grooved rolls for hard wire.*
2. *U-Grooved rolls for soft and soft shelled cored wires.*
3. *U-Cogged rolls for extremely soft shelled wires (usually hard surfacing types).*
4. *V-Knurled rolls for hard shelled cored wires.*
5. *Drive roll types may be mixed to suit particular requirements (example: V-Knurled roll in combination with U-Grooved).*

Wire Diameter			Drive Roll		Wire Guide
Metric	Fraction	Decimal	Part No.	Type	Inlet
0.6/0.8 mm*	0.023/0.030 in	0.023/0.030 in	156053051	V	156090022
0.8/1.0 mm*	0.030/0.035 in	0.030/0.035 in	156053109	V	
1.0/1.2 mm*	0.035/0.045 in	0.035/0.045 in	156053052	V	
0.8/1.0 mm**	0.035/0.045 in	0.030/0.035 in	156053053	U	
1.2/1.6 mm**	0.045/0.065 in	0.035/0.065 in	156053054	U	
1.0/1.2 mm*	0.035/0.045 in	0.035/0.045 in	1560531110	V-K	

* Available in: steel, 30 mm diameter

**Available in: nylon, 30 mm diameter

TRUE BLUE[®]

WARRANTY

Effective January 1, 2011
(Equipment with a serial number preface of MB or newer)

This limited warranty supersedes all previous Miller warranties and is exclusive with no other guarantees or warranties expressed or implied.

LIMITED WARRANTY – Subject to the terms and conditions below, ITW Welding Products Italy warrants to its original retail purchaser that new Miller equipment sold after the effective date of this limited warranty is free of defects in material and workmanship at the time it is shipped by Miller. THIS WARRANTY IS EXPRESSLY IN LIEU OF ALL OTHER WARRANTIES, EXPRESS OR IMPLIED, INCLUDING THE WARRANTIES OF MERCHANTABILITY AND FITNESS.

Within the warranty periods listed below, Miller will repair or replace any warranted parts or components that fail due to such defects in material or workmanship. Miller must be notified in writing within thirty (30) days of such defect or failure, at which time Miller will provide instructions on the warranty claim procedures to be followed.

Miller shall honor warranty claims on warranted equipment listed below in the event of such a failure within the warranty time periods. All warranty time periods start on the date the equipment was delivered to the original retail purchaser or one year after the equipment is shipped to a European distributor or eighteen months after the equipment is shipped to an International distributor.

1. 5 Years Parts — 3 Years Labor
 - * Original main power rectifiers only to include SCRs, diodes, and discrete rectifier modules
2. 3 Years — Parts and Labor
 - * Engine Driven Welding Generators
(NOTE: Engines are warranted separately by the engine manufacturer.)
 - * HF Units
 - * Inverter Power Sources (Unless Otherwise Stated)
 - * Process Controllers
 - * Semi-Automatic and Automatic Wire Feeders
 - * Transformer/Rectifier Power Sources
3. 2 Years — Parts
 - * Auto-Darkening Helmet Lenses (No Labor)
 - * Migmatic 171
4. 1 Year — Parts and Labor Unless Specified
 - * Automatic Motion Devices
 - * Field Options
(NOTE: Field options are covered under True Blue[®] for the remaining warranty period of the product they are installed in, or for a minimum of one year — whichever is greater.)
 - * Induction Heating Power Sources, Coolers, and Electronic Controls/Recorders
 - * Motor Driven Guns (w/exception of Spoolmate Spoolguns)
 - * Positioners and Controllers
 - * Powered Air Purifying Respirator (PAPR) Blower Unit (No Labor)
 - * Racks
 - * Running Gear and Trailers
 - * Subarc Wire Drive Assemblies
 - * Water Coolant Systems (Hydramate 1 and 2)
 - * Water Coolant Systems (USA Models, Non-Integrated)
 - * Work Stations/Weld Tables (No Labor)
5. 6 Months — Parts
 - * Batteries

6. 90 Days — Parts
 - * Accessory (Kits)
 - * Canvas Covers
 - * Induction Heating Coils and Blankets
 - * MIG Guns
 - * Remote Controls
 - * Replacement Parts (No Labor)
 - * Spoolmate Spoolguns

Miller's True Blue[®] Limited Warranty shall not apply to:

1. **Consumable components; such as contact tips, cutting nozzles, contactors, brushes, switches, slip rings, relays or parts that fail due to normal wear.**
2. Items furnished by Miller, but manufactured by others, such as engines or trade accessories. These items are covered by the manufacturer's warranty, if any.
3. Equipment that has been modified by any party other than Miller, or equipment that has been improperly installed, improperly operated or misused based upon industry standards, or equipment which has not had reasonable and necessary maintenance, or equipment which has been used for operation outside of the specifications for the equipment.

MILLER PRODUCTS ARE INTENDED FOR PURCHASE AND USE BY COMMERCIAL/INDUSTRIAL USERS AND PERSONS TRAINED AND EXPERIENCED IN THE USE AND MAINTENANCE OF WELDING EQUIPMENT.

In the event of a warranty claim covered by this warranty, the exclusive remedies shall be, at Miller's option: (1) repair; or (2) replacement; or, where authorized in writing by Miller in appropriate cases, (3) the reasonable cost of repair or replacement at an authorized Miller service station; or (4) payment of or credit for the purchase price (less reasonable depreciation based upon actual use) upon return of the goods at customer's risk and expense. Miller's option of repair or replacement will be F.O.B., Factory at ITW Welding Products Group Europe or F.O.B. at a Miller authorized service facility as determined by Miller. Therefore no compensation or reimbursement for transportation costs of any kind will be allowed.

TO THE EXTENT PERMITTED BY LAW, THE REMEDIES PROVIDED HEREIN ARE THE SOLE AND EXCLUSIVE REMEDIES. IN NO EVENT SHALL MILLER BE LIABLE FOR DIRECT, INDIRECT, SPECIAL, INCIDENTAL OR CONSEQUENTIAL DAMAGES (INCLUDING LOSS OF PROFIT), WHETHER BASED ON CONTRACT, TORT OR ANY OTHER LEGAL THEORY.

ANY EXPRESS WARRANTY NOT PROVIDED HEREIN AND ANY IMPLIED WARRANTY, GUARANTY OR REPRESENTATION AS TO PERFORMANCE, AND ANY REMEDY FOR BREACH OF CONTRACT TORT OR ANY OTHER LEGAL THEORY WHICH, BUT FOR THIS PROVISION, MIGHT ARISE BY IMPLICATION, OPERATION OF LAW, CUSTOM OF TRADE OR COURSE OF DEALING, INCLUDING ANY IMPLIED WARRANTY OF MERCHANTABILITY OR FITNESS FOR PARTICULAR PURPOSE, WITH RESPECT TO ANY AND ALL EQUIPMENT FURNISHED BY MILLER IS EXCLUDED AND DISCLAIMED BY MILLER.





Owner's Record

Please complete and retain with your personal records.

Model Name

Serial/Style Number

Purchase Date

(Date which equipment was delivered to original customer.)

Distributor

Address

Country

Zip/Postal Code



For Service

Contact a *DISTRIBUTOR* or *SERVICE AGENCY* near you.

Always provide Model Name and Serial/Style Number.

Contact your Distributor for:

Welding Supplies and Consumables

Options and Accessories

Service and Repair

Replacement Parts

Owner's Manuals

Contact the Delivering Carrier to:

File a claim for loss or damage during shipment.

For assistance in filing or settling claims, contact your distributor and/or equipment manufacturer's Transportation Department.

ITW Welding Products Italy S.r.l.

Via Privata Iseo, 6/E

20098 San Giuliano

Milanese, Italy

Phone: 39 (0) 2982901

Fax: 39 (0) 298290-203

email: miller@itw-welding.it

