





OM-263984F

2016-02

**Processes**

-  MIG (GMAW) Welding
-  Flux Cored (FCAW) Welding

**Description**



Wire Feeder

# SuitCase<sup>®</sup> 12RC

## CE And Non-CE Models

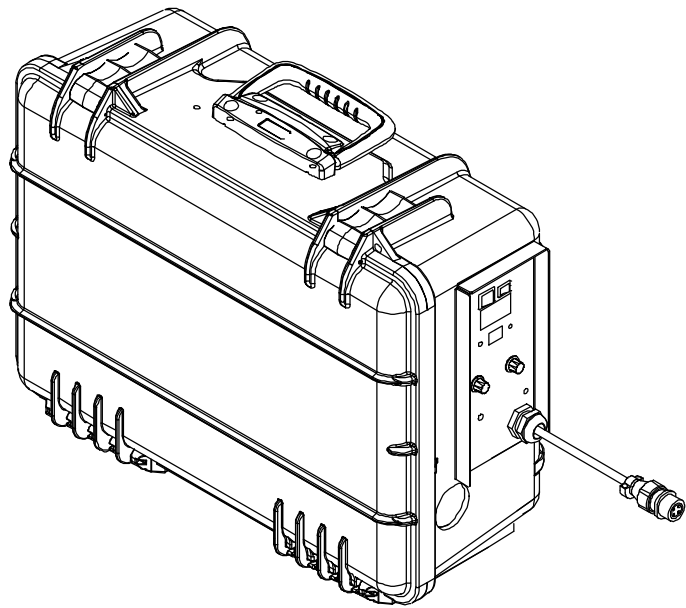

Visit our website at  
[www.MillerWelds.com](http://www.MillerWelds.com)

# OWNER'S MANUAL

File: MIG (GMAW)



# From Miller to You

---

*Thank you and congratulations* on choosing Miller. Now you can get the job done and get it done right. We know you don't have time to do it any other way.

That's why when Niels Miller first started building arc welders in 1929, he made sure his products offered long-lasting value and superior quality. Like you, his customers couldn't afford anything less. Miller products had to be more than the best they could be. They had to be the best you could buy.

Today, the people that build and sell Miller products continue the tradition. They're just as committed to providing equipment and service that meets the high standards of quality and value established in 1929.

This Owner's Manual is designed to help you get the most out of your Miller products. Please take time to read the Safety precautions. They will help you protect yourself against potential hazards on the worksite.

We've made installation and operation quick and easy. With Miller you can count on years of reliable service with proper maintenance. And if for some reason the unit needs repair, there's a Troubleshooting section that will help you figure out what the problem is. The parts list will then help you to decide the exact part you may need to fix the problem. Warranty and service information for your particular model are also provided.



Miller is the first welding equipment manufacturer in the U.S.A. to be registered to the ISO 9001 Quality System Standard.

Miller Electric manufactures a full line of welders and welding related equipment. For information on other quality Miller products, contact your local Miller distributor to receive the latest full line catalog or individual specification sheets. **To locate your nearest distributor or service agency call 1-800-4-A-Miller, or visit us at [www.MillerWelds.com](http://www.MillerWelds.com) on the web.**



Working as hard as you do – every power source from Miller is backed by the most hassle-free warranty in the business.



# TABLE OF CONTENTS

<b>SECTION 1 – SAFETY PRECAUTIONS - READ BEFORE USING</b> .....	<b>1</b>
1-1. Symbol Usage .....	1
1-2. Arc Welding Hazards .....	1
1-3. Additional Symbols For Installation, Operation, And Maintenance .....	3
1-4. California Proposition 65 Warnings .....	4
1-5. Principal Safety Standards .....	4
1-6. EMF Information .....	4
<b>SECTION 2 – CONSIGNES DE SÉCURITÉ – LIRE AVANT UTILISATION</b> .....	<b>5</b>
2-1. Symboles utilisés .....	5
2-2. Dangers relatifs au soudage à l'arc .....	5
2-3. Dangers supplémentaires en relation avec l'installation, le fonctionnement et la maintenance .....	7
2-4. Proposition californienne 65 Avertissements .....	8
2-5. Principales normes de sécurité .....	8
2-6. Informations relatives aux CEM .....	8
<b>SECTION 3 – DEFINITIONS</b> .....	<b>9</b>
3-1. Additional Safety Symbols And Definitions .....	9
3-2. Miscellaneous Symbols And Definitions .....	10
<b>SECTION 4 – SPECIFICATIONS</b> .....	<b>11</b>
4-1. Serial Number And Rating Label Location .....	11
4-2. Unit Specifications .....	11
4-3. Environmental Specifications .....	11
4-4. 14-Pin Plug Information .....	11
4-5. Gun Recommendation Table .....	11
<b>SECTION 5 – INSTALLATION</b> .....	<b>12</b>
5-1. Equipment Connection Diagram .....	12
5-2. Installing Drive Rolls .....	13
5-3. Connecting Welding Gun .....	14
5-4. Connecting Shielding Gas .....	15
5-5. Connecting Weld Cable .....	15
5-6. Selecting Cable Sizes* .....	16
5-7. Installing And Threading Welding Wire .....	17
<b>SECTION 6 – OPERATION</b> .....	<b>18</b>
6-1. Controls .....	18
6-2. Setting Digital Meter Board PC4 DIP Switches .....	19
6-3. Setting DIP Switches For Timer Models .....	20
<b>SECTION 7 – MAINTENANCE &amp; TROUBLESHOOTING</b> .....	<b>21</b>
7-1. Routine Maintenance .....	21
7-2. Overload Protection And Thermostat Protection .....	21
7-3. Cleaning Debris From Shielding Gas Filter Fitting .....	22
7-4. Troubleshooting .....	22
<b>SECTION 8 – ELECTRICAL DIAGRAMS</b> .....	<b>25</b>
<b>SECTION 9 – PARTS LIST</b> .....	<b>28</b>
<b>WARRANTY</b>	



# DECLARATION OF CONFORMITY

for European Community (CE marked) products.

**MILLER Electric Mfg. Co., 1635 Spencer Street, Appleton, WI 54914 U.S.A. declares that the product(s) identified in this declaration conform to the essential requirements and provisions of the stated Council Directive(s) and Standard(s).**

Product/Apparatus Identification:

Product	Stock Number
SUITCASE 12RC, HEAVY DUTY DRIVE	301121
SUITCASE 12RC, HDD 3S PRE/5S PTFLW, TH, BURNBACK	301121001

Council Directives:

- 2014/35/EU Low Voltage
- 2014/30/EU Electromagnetic Compatibility
- 2011/65/EU Restriction of the use of certain hazardous substances in electrical and electronic equipment

Standards:

- IEC 60974-5:2013 Arc Welding Equipment – Part 5: Wire feeders
- IEC 60974-10:2007 Arc Welding Equipment – Part 10: Electromagnetic compatibility (EMC) requirements

Signatory:

February 18, 2016

---

**David A. Werba**

MANAGER, PRODUCT DESIGN COMPLIANCE

---

Date of Declaration

# SECTION 1 – SAFETY PRECAUTIONS - READ BEFORE USING

som 2015-09

 Protect yourself and others from injury — read, follow, and save these important safety precautions and operating instructions.

## 1-1. Symbol Usage



**DANGER!** – Indicates a hazardous situation which, if not avoided, will result in death or serious injury. The possible hazards are shown in the adjoining symbols or explained in the text.



Indicates a hazardous situation which, if not avoided, could result in death or serious injury. The possible hazards are shown in the adjoining symbols or explained in the text.

**NOTICE** – Indicates statements not related to personal injury.

 Indicates special instructions.



This group of symbols means Warning! Watch Out! ELECTRIC SHOCK, MOVING PARTS, and HOT PARTS hazards. Consult symbols and related instructions below for necessary actions to avoid the hazards.

## 1-2. Arc Welding Hazards



The symbols shown below are used throughout this manual to call attention to and identify possible hazards. When you see the symbol, watch out, and follow the related instructions to avoid the hazard. The safety information given below is only a summary of the more complete safety information found in the Safety Standards listed in Section 1-5. Read and follow all Safety Standards.



Only qualified persons should install, operate, maintain, and repair this unit.



During operation, keep everybody, especially children, away.



### ELECTRIC SHOCK can kill.

Touching live electrical parts can cause fatal shocks or severe burns. The electrode and work circuit is electrically live whenever the output is on. The input power circuit and machine internal circuits are also live when power is on. In semiautomatic or automatic wire welding, the wire, wire reel, drive roll housing, and all metal parts touching the welding wire are electrically live. Incorrectly installed or improperly grounded equipment is a hazard.

- Do not touch live electrical parts.

- Wear dry, hole-free insulating gloves and body protection.
- Insulate yourself from work and ground using dry insulating mats or covers big enough to prevent any physical contact with the work or ground.
- Do not use AC output in damp areas, if movement is confined, or if there is a danger of falling.
- Use AC output ONLY if required for the welding process.
- If AC output is required, use remote output control if present on unit.
- Additional safety precautions are required when any of the following electrically hazardous conditions are present: in damp locations or while wearing wet clothing; on metal structures such as floors, gratings, or scaffolds; when in cramped positions such as sitting, kneeling, or lying; or when there is a high risk of unavoidable or accidental contact with the workpiece or ground. For these conditions, use the following equipment in order presented: 1) a semiautomatic DC constant voltage (wire) welder, 2) a DC manual (stick) welder, or 3) an AC welder with reduced open-circuit voltage. In most situations, use of a DC, constant voltage wire welder is recommended. And, do not work alone!
- Disconnect input power or stop engine before installing or servicing this equipment. Lockout/tagout input power according to OSHA 29 CFR 1910.147 (see Safety Standards).
- Properly install, ground, and operate this equipment according to its Owner's Manual and national, state, and local codes.

- Always verify the supply ground – check and be sure that input power cord ground wire is properly connected to ground terminal in disconnect box or that cord plug is connected to a properly grounded receptacle outlet.
- When making input connections, attach proper grounding conductor first – double-check connections.
- Keep cords dry, free of oil and grease, and protected from hot metal and sparks.
- Frequently inspect input power cord and ground conductor for damage or bare wiring – replace immediately if damaged – bare wiring can kill.
- Turn off all equipment when not in use.
- Do not use worn, damaged, undersized, or repaired cables.
- Do not drape cables over your body.
- If earth grounding of the workpiece is required, ground it directly with a separate cable.
- Do not touch electrode if you are in contact with the work, ground, or another electrode from a different machine.
- Do not touch electrode holders connected to two welding machines at the same time since double open-circuit voltage will be present.
- Use only well-maintained equipment. Repair or replace damaged parts at once. Maintain unit according to manual.
- Wear a safety harness if working above floor level.
- Keep all panels and covers securely in place.
- Clamp work cable with good metal-to-metal contact to workpiece or worktable as near the weld as practical.
- Insulate work clamp when not connected to workpiece to prevent contact with any metal object.
- Do not connect more than one electrode or work cable to any single weld output terminal. Disconnect cable for process not in use.
- Use GFCI protection when operating auxiliary equipment in damp or wet locations.

### SIGNIFICANT DC VOLTAGE exists in inverter welding power sources AFTER removal of input power.

- Turn Off inverter, disconnect input power, and discharge input capacitors according to instructions in Maintenance Section before touching any parts.



### HOT PARTS can burn.

- Do not touch hot parts bare handed.
- Allow cooling period before working on equipment.
- To handle hot parts, use proper tools and/or wear heavy, insulated welding gloves and clothing to prevent burns.



### FUMES AND GASES can be hazardous.

Welding produces fumes and gases. Breathing these fumes and gases can be hazardous to your health.

- Keep your head out of the fumes. Do not breathe the fumes.
- If inside, ventilate the area and/or use local forced ventilation at the arc to remove welding fumes and gases. The recommended way to determine adequate ventilation is to sample for the composition and quantity of fumes and gases to which personnel are exposed.
- If ventilation is poor, wear an approved air-supplied respirator.
- Read and understand the Safety Data Sheets (SDSs) and the manufacturer's instructions for adhesives, coatings, cleaners, consumables, coolants, degreasers, fluxes, and metals.
- Work in a confined space only if it is well ventilated, or while wearing an air-supplied respirator. Always have a trained watch-person nearby. Welding fumes and gases can displace air and lower the oxygen level causing injury or death. Be sure the breathing air is safe.
- Do not weld in locations near degreasing, cleaning, or spraying operations. The heat and rays of the arc can react with vapors to form highly toxic and irritating gases.
- Do not weld on coated metals, such as galvanized, lead, or cadmium plated steel, unless the coating is removed from the weld area, the area is well ventilated, and while wearing an air-supplied respirator. The coatings and any metals containing these elements can give off toxic fumes if welded.



### ARC RAYS can burn eyes and skin.

Arc rays from the welding process produce intense visible and invisible (ultraviolet and infrared) rays that can burn eyes and skin. Sparks fly off from the weld.

- Wear an approved welding helmet fitted with a proper shade of filter lenses to protect your face and eyes from arc rays and sparks when welding or watching (see ANSI Z49.1 and Z87.1 listed in Safety Standards).
- Wear approved safety glasses with side shields under your helmet.
- Use protective screens or barriers to protect others from flash, glare and sparks; warn others not to watch the arc.
- Wear body protection made from durable, flame-resistant material (leather, heavy cotton, wool). Body protection includes oil-free clothing such as leather gloves, heavy shirt, cuffless trousers, high shoes, and a cap.



### WELDING can cause fire or explosion.

Welding on closed containers, such as tanks, drums, or pipes, can cause them to blow up. Sparks can fly off from the welding arc. The flying sparks, hot workpiece, and hot equipment can cause fires and burns. Accidental contact of electrode to metal objects can cause sparks, explosion, overheating, or fire. Check and be sure the area is safe before doing any welding.

- Remove all flammables within 35 ft (10.7 m) of the welding arc. If this is not possible, tightly cover them with approved covers.
- Do not weld where flying sparks can strike flammable material.
- Protect yourself and others from flying sparks and hot metal.
- Be alert that welding sparks and hot materials from welding can easily go through small cracks and openings to adjacent areas.
- Watch for fire, and keep a fire extinguisher nearby.
- Be aware that welding on a ceiling, floor, bulkhead, or partition can cause fire on the hidden side.
- Do not weld on containers that have held combustibles, or on closed containers such as tanks, drums, or pipes unless they are properly prepared according to AWS F4.1 and AWS A6.0 (see Safety Standards).
- Do not weld where the atmosphere can contain flammable dust, gas, or liquid vapors (such as gasoline).
- Connect work cable to the work as close to the welding area as practical to prevent welding current from traveling long, possibly unknown paths and causing electric shock, sparks, and fire hazards.
- Do not use welder to thaw frozen pipes.

- Remove stick electrode from holder or cut off welding wire at contact tip when not in use.
- Wear body protection made from durable, flame-resistant material (leather, heavy cotton, wool). Body protection includes oil-free clothing such as leather gloves, heavy shirt, cuffless trousers, high shoes, and a cap.
- Remove any combustibles, such as a butane lighter or matches, from your person before doing any welding.
- After completion of work, inspect area to ensure it is free of sparks, glowing embers, and flames.
- Use only correct fuses or circuit breakers. Do not oversize or bypass them.
- Follow requirements in OSHA 1910.252 (a) (2) (iv) and NFPA 51B for hot work and have a fire watcher and extinguisher nearby.
- Read and understand the Safety Data Sheets (SDSs) and the manufacturer's instructions for adhesives, coatings, cleaners, consumables, coolants, degreasers, fluxes, and metals.

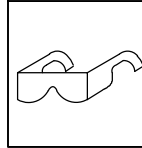

### FLYING METAL or DIRT can injure eyes.

- Welding, chipping, wire brushing, and grinding cause sparks and flying metal. As welds cool, they can throw off slag.
- Wear approved safety glasses with side shields even under your welding helmet.



### BUILDUP OF GAS can injure or kill.

- Shut off compressed gas supply when not in use.
- Always ventilate confined spaces or use approved air-supplied respirator.

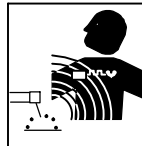

### ELECTRIC AND MAGNETIC FIELDS (EMF) can affect Implanted Medical Devices.

- Wearers of Pacemakers and other Implanted Medical Devices should keep away.
- Implanted Medical Device wearers should consult their doctor and the device manufacturer before going near arc welding, spot welding, gouging, plasma arc cutting, or induction heating operations.

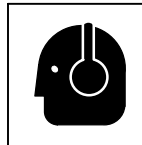

### NOISE can damage hearing.

Noise from some processes or equipment can damage hearing.

- Wear approved ear protection if noise level is high.

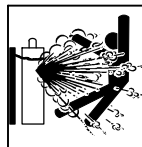

### CYLINDERS can explode if damaged.

Compressed gas cylinders contain gas under high pressure. If damaged, a cylinder can explode. Since gas cylinders are normally part of the welding process, be sure to treat them carefully.

- Protect compressed gas cylinders from excessive heat, mechanical shocks, physical damage, slag, open flames, sparks, and arcs.
- Install cylinders in an upright position by securing to a stationary support or cylinder rack to prevent falling or tipping.
- Keep cylinders away from any welding or other electrical circuits.
- Never drape a welding torch over a gas cylinder.
- Never allow a welding electrode to touch any cylinder.
- Never weld on a pressurized cylinder – explosion will result.
- Use only correct compressed gas cylinders, regulators, hoses, and fittings designed for the specific application; maintain them and associated parts in good condition.
- Turn face away from valve outlet when opening cylinder valve. Do not stand in front of or behind the regulator when opening the valve.
- Keep protective cap in place over valve except when cylinder is in use or connected for use.
- Use the right equipment, correct procedures, and sufficient number of persons to lift and move cylinders.
- Read and follow instructions on compressed gas cylinders, associated equipment, and Compressed Gas Association (CGA) publication P-1 listed in Safety Standards.

## 1-3. Additional Symbols For Installation, Operation, And Maintenance



### FIRE OR EXPLOSION hazard.

- Do not install or place unit on, over, or near combustible surfaces.
- Do not install unit near flammables.
- Do not overload building wiring – be sure power supply system is properly sized, rated, and protected to handle this unit.



### FALLING EQUIPMENT can injure.

- Use lifting eye to lift unit only, NOT running gear, gas cylinders, or any other accessories.
- Use equipment of adequate capacity to lift and support unit.
- If using lift forks to move unit, be sure forks are long enough to extend beyond opposite side of unit.
- Keep equipment (cables and cords) away from moving vehicles when working from an aerial location.
- Follow the guidelines in the Applications Manual for the Revised NIOSH Lifting Equation (Publication No. 94–110) when manually lifting heavy parts or equipment.

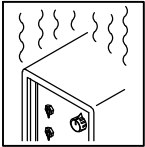

### OVERUSE can cause OVERHEATING

- Allow cooling period; follow rated duty cycle.
- Reduce current or reduce duty cycle before starting to weld again.
- Do not block or filter airflow to unit.

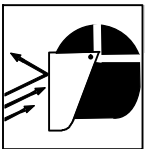

### FLYING SPARKS can injure.

- Wear a face shield to protect eyes and face.
- Shape tungsten electrode only on grinder with proper guards in a safe location wearing proper face, hand, and body protection.
- Sparks can cause fires — keep flammables away.

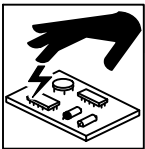

### STATIC (ESD) can damage PC boards.

- Put on grounded wrist strap BEFORE handling boards or parts.
- Use proper static-proof bags and boxes to store, move, or ship PC boards.



### MOVING PARTS can injure.

- Keep away from moving parts.
- Keep away from pinch points such as drive rolls.



### WELDING WIRE can injure.

- Do not press gun trigger until instructed to do so.
- Do not point gun toward any part of the body, other people, or any metal when threading welding wire.

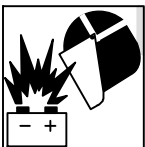

### BATTERY EXPLOSION can injure.

- Do not use welder to charge batteries or jump start vehicles unless it has a battery charging feature designed for this purpose.



### MOVING PARTS can injure.

- Keep away from moving parts such as fans.
- Keep all doors, panels, covers, and guards closed and securely in place.
- Have only qualified persons remove doors, panels, covers, or guards for maintenance and troubleshooting as necessary.
- Reinstall doors, panels, covers, or guards when maintenance is finished and before reconnecting input power.

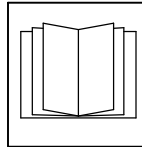

### READ INSTRUCTIONS.

- Read and follow all labels and the Owner's Manual carefully before installing, operating, or servicing unit. Read the safety information at the beginning of the manual and in each section.
- Use only genuine replacement parts from the manufacturer.
- Perform installation, maintenance, and service according to the Owner's Manuals, industry standards, and national, state, and local codes.

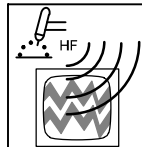

### H.F. RADIATION can cause interference.

- High-frequency (H.F.) can interfere with radio navigation, safety services, computers, and communications equipment.
- Have only qualified persons familiar with electronic equipment perform this installation.
- The user is responsible for having a qualified electrician promptly correct any interference problem resulting from the installation.
- If notified by the FCC about interference, stop using the equipment at once.
- Have the installation regularly checked and maintained.
- Keep high-frequency source doors and panels tightly shut, keep spark gaps at correct setting, and use grounding and shielding to minimize the possibility of interference.

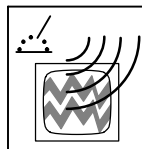

### ARC WELDING can cause interference.

- Electromagnetic energy can interfere with sensitive electronic equipment such as computers and computer-driven equipment such as robots.
- Be sure all equipment in the welding area is electromagnetically compatible.
- To reduce possible interference, keep weld cables as short as possible, close together, and down low, such as on the floor.
- Locate welding operation 100 meters from any sensitive electronic equipment.
- Be sure this welding machine is installed and grounded according to this manual.
- If interference still occurs, the user must take extra measures such as moving the welding machine, using shielded cables, using line filters, or shielding the work area.

## 1-4. California Proposition 65 Warnings

 **Welding or cutting equipment produces fumes or gases which contain chemicals known to the State of California to cause birth defects and, in some cases, cancer. (California Health & Safety Code Section 25249.5 et seq.)**

 **This product contains chemicals, including lead, known to the state of California to cause cancer, birth defects, or other reproductive harm. *Wash hands after use.***

## 1-5. Principal Safety Standards

*Safety in Welding, Cutting, and Allied Processes*, ANSI Standard Z49.1, is available as a free download from the American Welding Society at <http://www.aws.org> or purchased from Global Engineering Documents (phone: 1-877-413-5184, website: [www.global.ihs.com](http://www.global.ihs.com)).

*Safe Practices for the Preparation of Containers and Piping for Welding and Cutting*, American Welding Society Standard AWS F4.1, from Global Engineering Documents (phone: 1-877-413-5184, website: [www.global.ihs.com](http://www.global.ihs.com)).

*Safe Practices for Welding and Cutting Containers that have Held Combustibles*, American Welding Society Standard AWS A6.0, from Global Engineering Documents (phone: 1-877-413-5184, website: [www.global.ihs.com](http://www.global.ihs.com)).

*National Electrical Code*, NFPA Standard 70, from National Fire Protection Association, Quincy, MA 02269 (phone: 1-800-344-3555, website: [www.nfpa.org](http://www.nfpa.org) and [www.sparky.org](http://www.sparky.org)).

*Safe Handling of Compressed Gases in Cylinders*, CGA Pamphlet P-1, from Compressed Gas Association, 14501 George Carter Way, Suite 103, Chantilly, VA 20151 (phone: 703-788-2700, website: [www.cga-net.com](http://www.cga-net.com)).

*Safety in Welding, Cutting, and Allied Processes*, CSA Standard W117.2, from Canadian Standards Association, Standards Sales, 5060 Spectrum Way, Suite 100, Mississauga, Ontario, Canada L4W 5N5 (phone: 800-463-6727, website: [www.csagroup.org](http://www.csagroup.org)).

*Safe Practice For Occupational And Educational Eye And Face Protection*, ANSI Standard Z87.1, from American National Standards Institute, 25 West 43rd Street, New York, NY 10036 (phone: 212-642-4900, website: [www.ansi.org](http://www.ansi.org)).

*Standard for Fire Prevention During Welding, Cutting, and Other Hot Work*, NFPA Standard 51B, from National Fire Protection Association, Quincy, MA 02269 (phone: 1-800-344-3555, website: [www.nfpa.org](http://www.nfpa.org)).

OSHA, Occupational Safety and Health Standards for General Industry, Title 29, Code of Federal Regulations (CFR), Part 1910, Subpart Q, and Part 1926, Subpart J, from U.S. Government Printing Office, Superintendent of Documents, P.O. Box 371954, Pittsburgh, PA 15250-7954 (phone: 1-866-512-1800) (there are 10 OSHA Regional Offices—phone for Region 5, Chicago, is 312-353-2220, website: [www.osha.gov](http://www.osha.gov)).

*Applications Manual for the Revised NIOSH Lifting Equation*, The National Institute for Occupational Safety and Health (NIOSH), 1600 Clifton Rd, Atlanta, GA 30329-4027 (phone: 1-800-232-4636, website: [www.cdc.gov/NIOSH](http://www.cdc.gov/NIOSH)).

## 1-6. EMF Information

Electric current flowing through any conductor causes localized electric and magnetic fields (EMF). The current from arc welding (and allied processes including spot welding, gouging, plasma arc cutting, and induction heating operations) creates an EMF field around the welding circuit. EMF fields can interfere with some medical implants, e.g. pacemakers. Protective measures for persons wearing medical implants have to be taken. For example, restrict access for passers-by or conduct individual risk assessment for welders. All welders should use the following procedures in order to minimize exposure to EMF fields from the welding circuit:

1. Keep cables close together by twisting or taping them, or using a cable cover.
2. Do not place your body between welding cables. Arrange cables to one side and away from the operator.
3. Do not coil or drape cables around your body.

4. Keep head and trunk as far away from the equipment in the welding circuit as possible.
5. Connect work clamp to workpiece as close to the weld as possible.
6. Do not work next to, sit or lean on the welding power source.
7. Do not weld whilst carrying the welding power source or wire feeder.

### About Implanted Medical Devices:

Implanted Medical Device wearers should consult their doctor and the device manufacturer before performing or going near arc welding, spot welding, gouging, plasma arc cutting, or induction heating operations. If cleared by your doctor, then following the above procedures is recommended.



# SECTION 2 – CONSIGNES DE SÉCURITÉ – LIRE AVANT UTILISATION

fre\_som\_2015-09

**!** Pour écarter les risques de blessure pour vous-même et pour autrui — lire, appliquer et ranger en lieu sûr ces consignes relatives aux précautions de sécurité et au mode opératoire.

## 2-1. Symboles utilisés



**DANGER!** – Indique une situation dangereuse qui si on l'évite pas peut donner la mort ou des blessures graves. Les dangers possibles sont montrés par les symboles joints ou sont expliqués dans le texte.



Indique une situation dangereuse qui si on l'évite pas peut donner la mort ou des blessures graves. Les dangers possibles sont montrés par les symboles joints ou sont expliqués dans le texte.

*AVIS* – Indique des déclarations pas en relation avec des blessures personnelles.

 Indique des instructions spécifiques.



Ce groupe de symboles veut dire Avertissement! Attention! DANGER DE CHOC ELECTRIQUE, PIECES EN MOUVEMENT, et PIECES CHAUDES. Consulter les symboles et les instructions ci-dessous y afférant pour les actions nécessaires afin d'éviter le danger.

## 2-2. Dangers relatifs au soudage à l'arc



Les symboles représentés ci-dessous sont utilisés dans ce manuel pour attirer l'attention et identifier les dangers possibles. En présence de l'un de ces symboles, prendre garde et suivre les instructions afférentes pour éviter tout risque. Les instructions en matière de sécurité indiquées ci-dessous ne constituent qu'un sommaire des instructions de sécurité plus complètes fournies dans les normes de sécurité énumérées dans la Section 2-5. Lire et observer toutes les normes de sécurité.



Seul un personnel qualifié est autorisé à installer, faire fonctionner, entretenir et réparer cet appareil.



Pendant le fonctionnement, maintenir à distance toutes les personnes, notamment les enfants de l'appareil.



### UNE DÉCHARGE ÉLECTRIQUE peut entraîner la mort.

Le contact d'organes électriques sous tension peut provoquer des accidents mortels ou des brûlures graves. Le circuit de l'électrode et de la pièce est sous tension lorsque le courant est délivré à la sortie. Le circuit d'alimentation et les circuits internes de la machine sont également sous tension lorsque l'alimentation est sur Marche. Dans le mode de soudage avec du fil, le fil, le dérouleur, le bloc de commande du rouleau et toutes les parties métalliques en contact avec le fil sont sous tension électrique. Un équipement installé ou mis à la terre de manière incorrecte ou impropre constitue un danger.

- Ne pas toucher aux pièces électriques sous tension.
- Porter des gants isolants et des vêtements de protection secs et sans trous.
- S'isoler de la pièce à couper et du sol en utilisant des housses ou des tapis assez grands afin d'éviter tout contact physique avec la pièce à couper ou le sol.
- Ne pas se servir de source électrique à courant électrique dans les zones humides, dans les endroits confinés ou là où on risque de tomber.
- Se servir d'une source électrique à courant électrique UNIQUEMENT si le procédé de soudage le demande.
- Si l'utilisation d'une source électrique à courant électrique s'avère nécessaire, se servir de la fonction de télécommande si l'appareil en est équipé.
- D'autres consignes de sécurité sont nécessaires dans les conditions suivantes : risques électriques dans un environnement humide ou si l'on porte des vêtements mouillés ; sur des structures métalliques telles que sols, grilles ou échafaudages ; en position coincée comme assise, à genoux ou couchée ; ou s'il y a un risque élevé de contact inévitable ou accidentel avec la pièce à souder ou le sol. Dans ces conditions, utiliser les équipements suivants, dans l'ordre indiqué : 1) un poste à souder DC à tension constante (à fil), 2) un poste à souder DC manuel (électrode) ou 3) un poste à souder AC à tension à vide réduite. Dans la plupart des situations, l'utilisation d'un poste à souder DC à fil à tension constante est recommandée. En outre, ne pas travailler seul !

- Couper l'alimentation ou arrêter le moteur avant de procéder à l'installation, à la réparation ou à l'entretien de l'appareil. Déverrouiller l'alimentation selon la norme OSHA 29 CFR 1910.147 (voir normes de sécurité).
- Installez, mettez à la terre et utilisez correctement cet équipement conformément à son Manuel d'Utilisation et aux réglementations nationales, gouvernementales et locales.
- Toujours vérifier la terre du cordon d'alimentation. Vérifier et s'assurer que le fil de terre du cordon d'alimentation est bien raccordé à la borne de terre du sectionneur ou que la fiche du cordon est raccordée à une prise correctement mise à la terre.
- En effectuant les raccordements d'entrée, fixer d'abord le conducteur de mise à la terre approprié et contre-vérifier les connexions.
- Les câbles doivent être exempts d'humidité, d'huile et de graisse; protégez-les contre les étincelles et les pièces métalliques chaudes.
- Vérifier fréquemment le cordon d'alimentation et le conducteur de mise à la terre afin de s'assurer qu'il n'est pas altéré ou dénudé –, le remplacer immédiatement s'il l'est –. Un fil dénudé peut entraîner la mort.
- L'équipement doit être hors tension lorsqu'il n'est pas utilisé.
- Ne pas utiliser des câbles usés, endommagés, de grosseur insuffisante ou mal épissés.
- Ne pas enrouler les câbles autour du corps.
- Si la pièce soudée doit être mise à la terre, le faire directement avec un câble distinct.
- Ne pas toucher l'électrode quand on est en contact avec la pièce, la terre ou une électrode provenant d'une autre machine.
- Ne pas toucher des porte électrodes connectés à deux machines en même temps à cause de la présence d'une tension à vide doublée.
- N'utiliser qu'un matériel en bon état. Réparer ou remplacer sur-le-champ les pièces endommagées. Entretien l'appareil conformément à ce manuel.
- Porter un harnais de sécurité si l'on doit travailler au-dessus du sol.
- S'assurer que tous les panneaux et couvercles sont correctement en place.
- Fixer le câble de retour de façon à obtenir un bon contact métal-métal avec la pièce à souder ou la table de travail, le plus près possible de la soudure.
- Isoler la pince de masse quand pas mis à la pièce pour éviter le contact avec tout objet métallique.
- Ne pas raccorder plus d'une électrode ou plus d'un câble de masse à une même borne de sortie de soudage. Débrancher le câble pour le procédé non utilisé.
- Utiliser une protection différentielle lors de l'utilisation d'un équipement auxiliaire dans des endroits humides ou mouillés.

### Il reste une TENSION DC NON NÉGLIGEABLE dans les sources de soudage onduleur UNE FOIS l'alimentation coupée.

- Arrêter les convertisseurs, débrancher le courant électrique et décharger les condensateurs d'alimentation selon les instructions indiquées dans la partie Entretien avant de toucher les pièces.



### LES PIÈCES CHAUDES peuvent provoquer des brûlures.

- Ne pas toucher à mains nues les parties chaudes.
- Prévoir une période de refroidissement avant de travailler à l'équipement.
- Ne pas toucher aux pièces chaudes, utiliser les outils recommandés et porter des gants de soudage et des vêtements épais pour éviter les brûlures.

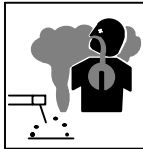

### LES FUMÉES ET LES GAZ peuvent être dangereux.

Le soudage génère des fumées et des gaz. Leur inhalation peut être dangereux pour votre santé.

- Eloigner votre tête des fumées. Ne pas respirer les fumées.
- À l'intérieur, ventiler la zone et/ou utiliser une ventilation forcée au niveau de l'arc pour l'évacuation des fumées et des gaz de soudage. Pour déterminer la bonne ventilation, il est recommandé de procéder à un prélèvement pour la composition et la quantité de fumées et de gaz auxquels est exposé le personnel.
- Si la ventilation est médiocre, porter un respirateur anti-vapeurs approuvé.
- Lire et comprendre les fiches de données de sécurité et les instructions du fabricant concernant les adhésifs, les revêtements, les nettoyants, les consommables, les produits de refroidissement, les dégraisseurs, les flux et les métaux.
- Travailler dans un espace fermé seulement s'il est bien ventilé ou en portant un respirateur à alimentation d'air. Demander toujours à un surveillant dûment formé de se tenir à proximité. Des fumées et des gaz de soudage peuvent déplacer l'air et abaisser le niveau d'oxygène provoquant des blessures ou des accidents mortels. S'assurer que l'air de respiration ne présente aucun danger.
- Ne pas souder dans des endroits situés à proximité d'opérations de dégraissage, de nettoyage ou de pulvérisation. La chaleur et les rayons de l'arc peuvent réagir en présence de vapeurs et former des gaz hautement toxiques et irritants.
- Ne pas souder des métaux munis d'un revêtement, tels que l'acier galvanisé, plaqué en plomb ou au cadmium à moins que le revêtement n'ait été enlevé dans la zone de soudure, que l'endroit soit bien ventilé, et en portant un respirateur à alimentation d'air. Les revêtements et tous les métaux renfermant ces éléments peuvent dégager des fumées toxiques en cas de soudage.



### LES RAYONS DE L'ARC peuvent provoquer des brûlures dans les yeux et sur la peau.

Le rayonnement de l'arc du procédé de soudage génère des rayons visibles et invisibles intenses (ultraviolets et infrarouges) susceptibles de provoquer des brûlures dans les yeux et sur la peau. Des étincelles sont projetées pendant le soudage.

- Porter un casque de soudage approuvé muni de verres filtrants appropriés pour protéger visage et yeux pour protéger votre visage et vos yeux pendant le soudage ou pour regarder (voir ANSI Z49.1 et Z87.1 énuméré dans les normes de sécurité).
- Porter des lunettes de sécurité avec écrans latéraux même sous votre casque.
- Avoir recours à des écrans protecteurs ou à des rideaux pour protéger les autres contre les rayonnements les éblouissements et les étincelles ; prévenir toute personne sur les lieux de ne pas regarder l'arc.
- Porter un équipement de protection pour le corps fait d'un matériau résistant et ignifuge (cuir, coton robuste, laine). La protection du corps comporte des vêtements sans huile comme par ex. des gants de cuir, une chemise solide, des pantalons sans revers, des chaussures hautes et une casquette.

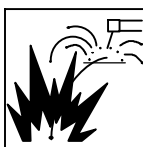

### LE SOUDAGE peut provoquer un incendie ou une explosion.

Le soudage effectué sur des conteneurs fermés tels que des réservoirs, tambours ou des conduites peut provoquer leur éclatement. Des étincelles peuvent être projetées de l'arc de soudure. La projection d'étincelles, des

pièces chaudes et des équipements chauds peut provoquer des incendies et des brûlures. Le contact accidentel de l'électrode avec des objets métalliques peut provoquer des étincelles, une explosion, un sur-

chauffement ou un incendie. Avant de commencer le soudage, vérifier et s'assurer que l'endroit ne présente pas de danger.

- Déplacer toutes les substances inflammables à une distance de 10,7 m de l'arc de soudage. En cas d'impossibilité les recouvrir soigneusement avec des protections homologués.
- Ne pas souder dans un endroit où des étincelles peuvent tomber sur des substances inflammables.
- Se protéger et d'autres personnes de la projection d'étincelles et de métal chaud.
- Des étincelles et des matériaux chauds du soudage peuvent facilement passer dans d'autres zones en traversant de petites fissures et des ouvertures.
- Surveiller tout déclenchement d'incendie et tenir un extincteur à proximité.
- Le soudage effectué sur un plafond, plancher, paroi ou séparation peut déclencher un incendie de l'autre côté.
- Ne pas effectuer le soudage sur des conteneurs fermés tels que des réservoirs, tambours, ou conduites, à moins qu'ils n'aient été préparés correctement conformément à AWS F4.1 et AWS A6.0 (voir les Normes de Sécurité).
- Ne pas souder là où l'air ambiant pourrait contenir des poussières, gaz ou émanations inflammables (vapeur d'essence, par exemple).
- Brancher le câble de masse sur la pièce la plus près possible de la zone de soudage pour éviter le transport du courant sur une longue distance par des chemins inconnus éventuels en provoquant des risques d'électrocution, d'étincelles et d'incendie.
- Ne pas utiliser le poste de soudage pour dégeler des conduites gelées.
- En cas de non utilisation, enlever la baguette d'électrode du porte-électrode ou couper le fil à la pointe de contact.
- Porter un équipement de protection pour le corps fait d'un matériau résistant et ignifuge (cuir, coton robuste, laine). La protection du corps comporte des vêtements sans huile comme par ex. des gants de cuir, une chemise solide, des pantalons sans revers, des chaussures hautes et une casquette.
- Avant de souder, retirer toute substance combustible de vos poches telles qu'un allumeur au butane ou des allumettes.
- Une fois le travail achevé, assurez-vous qu'il ne reste aucune trace d'étincelles incandescentes ni de flammes.
- Utiliser exclusivement des fusibles ou coupe-circuits appropriés. Ne pas augmenter leur puissance; ne pas les ponter.
- Suivre les recommandations dans OSHA 1910.252(a)(2)(iv) et NFPA 51B pour les travaux à chaud et avoir de la surveillance et un extincteur à proximité.
- Lire et comprendre les fiches de données de sécurité et les instructions du fabricant concernant les adhésifs, les revêtements, les nettoyants, les consommables, les produits de refroidissement, les dégraisseurs, les flux et les métaux.

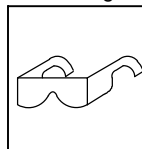

### DES PIÈCES DE METAL ou DES SALETES peuvent provoquer des blessures dans les yeux.

- Le soudage, l'écaillage, le passage de la pièce à la brosse en fil de fer, et le meulage génèrent des étincelles et des particules métalliques volantes. Pendant la période de refroidissement des soudures, elles risquent de projeter du laitier.
- Porter des lunettes de sécurité avec écrans latéraux ou un écran facial.



### LES ACCUMULATIONS DE GAZ risquent de provoquer des blessures ou même la mort.

- Fermer l'alimentation du gaz comprimé en cas de non utilisation.
- Veiller toujours à bien aérer les espaces confinés ou se servir d'un respirateur d'adduction d'air homologué.

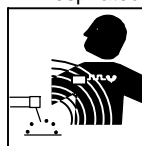

### Les CHAMPS ÉLECTROMAGNÉTIQUES (CEM) peuvent affecter les implants médicaux.

- Les porteurs de stimulateurs cardiaques et autres implants médicaux doivent rester à distance.
- Les porteurs d'implants médicaux doivent consulter leur médecin et le fabricant du dispositif avant de s'approcher de la zone où se

déroule du soudage à l'arc, du soudage par points, du gougeage, de la découpe plasma ou une opération de chauffage par induction.



### LE BRUIT peut endommager l'ouïe.

Le bruit des processus et des équipements peut affecter l'ouïe.

- Porter des protections approuvées pour les oreilles si le niveau sonore est trop élevé.



### LES BOUTEILLES peuvent exploser si elles sont endommagées.

Les bouteilles de gaz comprimé contiennent du gaz sous haute pression. Si une bouteille est endommagée, elle peut exploser. Du fait que

les bouteilles de gaz font normalement partie du procédé de soudage, les manipuler avec précaution.

- Protéger les bouteilles de gaz comprimé d'une chaleur excessive, des chocs mécaniques, des dommages physiques, du laitier, des flammes ouvertes, des étincelles et des arcs.

- Placer les bouteilles debout en les fixant dans un support stationnaire ou dans un porte-bouteilles pour les empêcher de tomber ou de se renverser.
- Tenir les bouteilles éloignées des circuits de soudage ou autres circuits électriques.
- Ne jamais placer une torche de soudage sur une bouteille à gaz.
- Une électrode de soudage ne doit jamais entrer en contact avec une bouteille.
- Ne jamais souder une bouteille pressurisée – risque d'explosion.
- Utiliser seulement des bouteilles de gaz comprimé, régulateurs, tuyaux et raccords convenables pour cette application spécifique; les maintenir ainsi que les éléments associés en bon état.
- Tourner le dos à la sortie de vanne lors de l'ouverture de la vanne de la bouteille. Ne pas se tenir devant ou derrière le régulateur lors de l'ouverture de la vanne.
- Le couvercle du détendeur doit toujours être en place, sauf lorsque la bouteille est utilisée ou qu'elle est reliée pour usage ultérieur.
- Utiliser les équipements corrects, les bonnes procédures et suffisamment de personnes pour soulever et déplacer les bouteilles.
- Lire et suivre les instructions sur les bouteilles de gaz comprimé, l'équipement connexe et le dépliant P-1 de la CGA (Compressed Gas Association) mentionné dans les principales normes de sécurité.

## 2-3. Dangers supplémentaires en relation avec l'installation, le fonctionnement et la maintenance



### Risque D'INCENDIE OU D'EXPLOSION.

- Ne pas placer l'appareil sur, au-dessus ou à proximité de surfaces inflammables.
- Ne pas installer l'appareil à proximité de produits inflammables.

- Ne pas surcharger l'installation électrique – s'assurer que l'alimentation est correctement dimensionnée et protégée avant de mettre l'appareil en service.



### LA CHUTE DE L'ÉQUIPEMENT peut provoquer des blessures.

- Utiliser l'anneau de levage uniquement pour soulever l'appareil, NON PAS les chariots, les bouteilles de gaz ou tout autre accessoire.

- Utiliser un équipement de levage de capacité suffisante pour lever l'appareil.
- En utilisant des fourches de levage pour déplacer l'unité, s'assurer que les fourches sont suffisamment longues pour dépasser du côté opposé de l'appareil.
- Tenir l'équipement (câbles et cordons) à distance des véhicules mobiles lors de toute opération en hauteur.
- Suivre les consignes du Manuel des applications pour l'équation de levage NIOSH révisée (Publication N°94-110) lors du levage manuel de pièces ou équipements lourds.

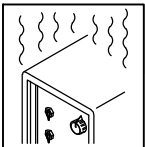

### L'EMPLOI EXCESSIF peut SURCHAUFFER L'ÉQUIPEMENT.

- Prévoir une période de refroidissement ; respecter le cycle opératoire nominal.
- Réduire le courant ou le facteur de marche avant de poursuivre le soudage.

- Ne pas obstruer les passages d'air du poste.

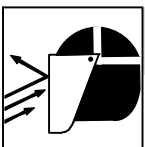

### LES ÉTINCELLES PROJÉTÉES peuvent provoquer des blessures.

- Porter un écran facial pour protéger le visage et les yeux.

• Affûter l'électrode au tungstène uniquement à la meuleuse dotée de protecteurs. Cette manœuvre est à exécuter dans un endroit sûr lorsque l'on porte l'équipement homologué de protection du visage, des mains et du corps.

- Les étincelles risquent de causer un incendie – éloigner toute substance inflammable.

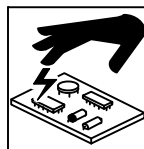

### LES CHARGES ÉLECTROSTATIQUES peuvent endommager les circuits imprimés.

- Établir la connexion avec la barrette de terre avant de manipuler des cartes ou des pièces.

- Utiliser des pochettes et des boîtes antistatiques pour stocker, déplacer ou expédier des cartes de circuits imprimés.

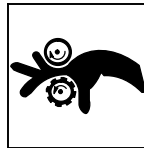

### Les PIÈCES MOBILES peuvent causer des blessures.

- Ne pas s'approcher des organes mobiles.
- Ne pas s'approcher des points de coincement tels que des rouleaux de commande.



### LES FILS DE SOUDAGE peuvent provoquer des blessures.

- Ne pas appuyer sur la gâchette avant d'en avoir reçu l'instruction.

- Ne pas diriger le pistolet vers soi, d'autres personnes ou toute pièce mécanique en engageant le fil de soudage.

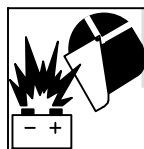

### L'EXPLOSION DE LA BATTERIE peut provoquer des blessures.

- Ne pas utiliser l'appareil de soudage pour charger des batteries ou faire démarrer des véhicules à l'aide de câbles de démarrage, sauf si l'appareil dispose d'une fonctionnalité de charge de batterie destinée à cet usage.



### Les PIÈCES MOBILES peuvent causer des blessures.

- S'abstenir de toucher des organes mobiles tels que des ventilateurs.

- Maintenir fermés et verrouillés les portes, panneaux, recouvrements et dispositifs de protection.

- Lorsque cela est nécessaire pour des travaux d'entretien et de dépannage, faire retirer les portes, panneaux, recouvrements ou dispositifs de protection uniquement par du personnel qualifié.

- Remettre les portes, panneaux, recouvrements ou dispositifs de protection quand l'entretien est terminé et avant de rebrancher l'alimentation électrique.

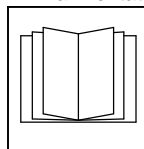

### LIRE LES INSTRUCTIONS.

- Lire et appliquer les instructions sur les étiquettes et le Mode d'emploi avant l'installation, l'utilisation ou l'entretien de l'appareil. Lire les informations de sécurité au début du manuel et dans chaque section.

- N'utiliser que les pièces de rechange recommandées par le constructeur.
- Effectuer l'installation, l'entretien et toute intervention selon les manuels d'utilisateurs, les normes nationales, provinciales et de l'industrie, ainsi que les codes municipaux.

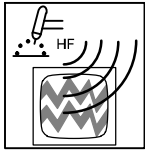

### LE RAYONNEMENT HAUTE FRÉQUENCE (H.F.) risque de provoquer des interférences.

- Le rayonnement haute fréquence (H.F.) peut provoquer des interférences avec les équipements de radio-navigation et de communication, les services de sécurité et les ordinateurs.
- Demander seulement à des personnes qualifiées familiarisées avec des équipements électroniques de faire fonctionner l'installation.
- L'utilisateur est tenu de faire corriger rapidement par un électricien qualifié les interférences résultant de l'installation.
- Si le FCC signale des interférences, arrêter immédiatement l'appareil.
- Effectuer régulièrement le contrôle et l'entretien de l'installation.
- Maintenir soigneusement fermés les portes et les panneaux des sources de haute fréquence, maintenir les éclateurs à une distance correcte et utiliser une terre et un blindage pour réduire les interférences éventuelles.

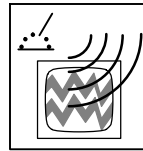

### LE SOUDAGE À L'ARC risque de provoquer des interférences.

- L'énergie électromagnétique risque de provoquer des interférences pour l'équipement électronique sensible tel que les ordinateurs et l'équipement commandé par ordinateur tel que les robots.
- Veiller à ce que tout l'équipement de la zone de soudage soit compatible électromagnétiquement.
- Pour réduire la possibilité d'interférence, maintenir les câbles de soudage aussi courts que possible, les grouper, et les poser aussi bas que possible (ex. par terre).
- Veiller à souder à une distance de 100 mètres de tout équipement électronique sensible.
- Veiller à ce que ce poste de soudage soit posé et mis à la terre conformément à ce mode d'emploi.
- En cas d'interférences après avoir pris les mesures précédentes, il incombe à l'utilisateur de prendre des mesures supplémentaires telles que le déplacement du poste, l'utilisation de câbles blindés, l'utilisation de filtres de ligne ou la pose de protecteurs dans la zone de travail.

## 2-4. Proposition californienne 65 Avertissements

**⚠ Les équipements de soudage et de coupage produisent des fumées et des gaz qui contiennent des produits chimiques dont l'État de Californie reconnaît qu'ils provoquent des malformations congénitales et, dans certains cas, des cancers. (Code de santé et de sécurité de Californie, chapitre 25249.5 et suivants)**

**⚠ Ce produit contient des produits chimiques, notamment du plomb, dont l'État de Californie reconnaît qu'ils provoquent des cancers, des malformations congénitales ou d'autres problèmes de procréation. Se laver les mains après utilisation.**

## 2-5. Principales normes de sécurité

*Safety in Welding, Cutting, and Allied Processes*, ANSI Standard Z49.1, is available as a free download from the American Welding Society at <http://www.aws.org> or purchased from Global Engineering Documents (phone: 1-877-413-5184, website: [www.global.ihs.com](http://www.global.ihs.com)).

*Safe Practices for the Preparation of Containers and Piping for Welding and Cutting*, American Welding Society Standard AWS F4.1, from Global Engineering Documents (phone: 1-877-413-5184, website: [www.global.ihs.com](http://www.global.ihs.com)).

*Safe Practices for Welding and Cutting Containers that have Held Combustibles*, American Welding Society Standard AWS A6.0, from Global Engineering Documents (phone: 1-877-413-5184, website: [www.global.ihs.com](http://www.global.ihs.com)).

*National Electrical Code*, NFPA Standard 70, from National Fire Protection Association, Quincy, MA 02269 (phone: 1-800-344-3555, website: [www.nfpa.org](http://www.nfpa.org) and [www.sparky.org](http://www.sparky.org)).

*Safe Handling of Compressed Gases in Cylinders*, CGA Pamphlet P-1, from Compressed Gas Association, 14501 George Carter Way, Suite 103, Chantilly, VA 20151 (phone: 703-788-2700, website: [www.cganet.com](http://www.cganet.com)).

*Safety in Welding, Cutting, and Allied Processes*, CSA Standard W117.2, from Canadian Standards Association, Standards Sales, 5060

Spectrum Way, Suite 100, Mississauga, Ontario, Canada L4W 5N5 (phone: 800-463-6727, website: [www.csagroup.org](http://www.csagroup.org)).

*Safe Practice For Occupational And Educational Eye And Face Protection*, ANSI Standard Z87.1, from American National Standards Institute, 25 West 43rd Street, New York, NY 10036 (phone: 212-642-4900, website: [www.ansi.org](http://www.ansi.org)).

*Standard for Fire Prevention During Welding, Cutting, and Other Hot Work*, NFPA Standard 51B, from National Fire Protection Association, Quincy, MA 02269 (phone: 1-800-344-3555, website: [www.nfpa.org](http://www.nfpa.org)).

OSHA, Occupational Safety and Health Standards for General Industry, Title 29, Code of Federal Regulations (CFR), Part 1910, Subpart Q, and Part 1926, Subpart J, from U.S. Government Printing Office, Superintendent of Documents, P.O. Box 371954, Pittsburgh, PA 15250-7954 (phone: 1-866-512-1800) (there are 10 OSHA Regional Offices—phone for Region 5, Chicago, is 312-353-2220, website: [www.osha.gov](http://www.osha.gov)).

*Applications Manual for the Revised NIOSH Lifting Equation*, The National Institute for Occupational Safety and Health (NIOSH), 1600 Clifton Rd, Atlanta, GA 30329-4027 (phone: 1-800-232-4636, website: [www.cdc.gov/NIOSH](http://www.cdc.gov/NIOSH)).

## 2-6. Informations relatives aux CEM

Le courant électrique qui traverse tout conducteur génère des champs électromagnétiques (CEM) à certains endroits. Le courant issu d'un soudage à l'arc (et de procédés connexes, y compris le soudage par points, le gougeage, le découpage plasma et les opérations de chauffage par induction) crée un champ électromagnétique (CEM) autour du circuit de soudage. Les champs électromagnétiques produits peuvent causer interférence à certains implants médicaux, p. ex. les stimulateurs cardiaques. Des mesures de protection pour les porteurs d'implants médicaux doivent être prises: Limiter par exemple tout accès aux passants ou procéder à une évaluation des risques individuels pour les soudeurs. Tous les soudeurs doivent appliquer les procédures suivantes pour minimiser l'exposition aux CEM provenant du circuit de soudage:

1. Rassembler les câbles en les torsadant ou en les attachant avec du ruban adhésif ou avec une housse.
2. Ne pas se tenir au milieu des câbles de soudage. Disposer les

câbles d'un côté et à distance de l'opérateur.

3. Ne pas courber et ne pas entourer les câbles autour de votre corps.
4. Maintenir la tête et le torse aussi loin que possible du matériel du circuit de soudage.
5. Connecter la pince sur la pièce aussi près que possible de la soudure.
6. Ne pas travailler à proximité d'une source de soudage, ni s'asseoir ou se pencher dessus.
7. Ne pas souder tout en portant la source de soudage ou le dévidoir.





### En ce qui concerne les implants médicaux :



Les porteurs d'implants doivent d'abord consulter leur médecin avant de s'approcher des opérations de soudage à l'arc, de soudage par points, de gougeage, du coupage plasma ou de chauffage par induction. Si le médecin approuve, il est recommandé de suivre les procédures précédentes.

# SECTION 3 – DEFINITIONS

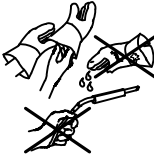
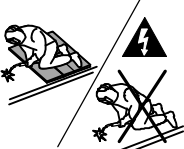
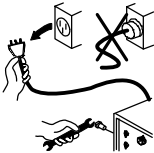
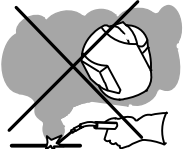
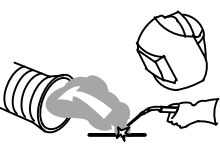
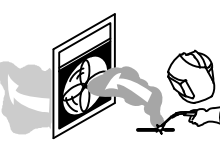



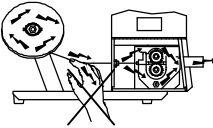
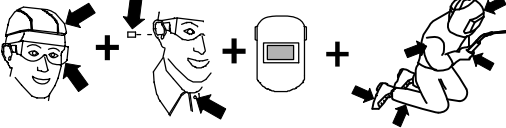
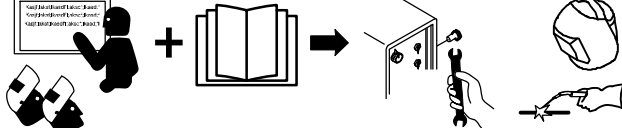

## 3-1. Additional Safety Symbols And Definitions











 Some symbols are found only on CE products.









	<p>Warning! Watch Out! There are possible hazards as shown by the symbols.</p> <p style="text-align: right;">Safe1 2012-05</p>
	<p>Do not discard product (where applicable) with general waste. Reuse or recycle Waste Electrical and Electronic Equipment (WEEE) by disposing at a designated collection facility. Contact your local recycling office or your local distributor for further information.</p> <p style="text-align: right;">Safe37 2012-05</p>
	<p>Wear dry insulating gloves. Do not touch electrode (wire) with bare hand. Do not wear wet or damaged gloves.</p> <p style="text-align: right;">Safe57 2012-05</p>
	<p>Protect yourself from electric shock by insulating yourself from work and ground.</p> <p style="text-align: right;">Safe58 2012-06</p>
	<p>Disconnect input plug or power before working on machine.</p> <p style="text-align: right;">Safe5 2012-05</p>
	<p>Keep your head out of the fumes.</p> <p style="text-align: right;">Safe59 2012-05</p>
	<p>Use forced ventilation or local exhaust to remove the fumes.</p> <p style="text-align: right;">Safe60 2012-06</p>
	<p>Use ventilating fan to remove fumes.</p> <p style="text-align: right;">Safe61 2012-06</p>
	<p>Keep flammables away from welding. Do not weld near flammables.</p> <p style="text-align: right;">Safe62 2012-06</p>
	<p>Welding sparks can cause fires. Have a fire extinguisher nearby, and have a watchperson ready to use it.</p> <p style="text-align: right;">Safe63 2012-06</p>

	Do not weld on drums or any closed containers.	Safe64 2012-06
	Do not remove or paint over (cover) the label.	Safe20 2012-05
	Drive rolls can injure fingers.	Safe32 2012-05
	Welding wire and drive parts are at welding voltage during operation – keep hands and metal objects away.	Safe33 2012-05
	Wear hat and safety glasses. Use ear protection and button shirt collar. Use welding helmet with correct shade of filter. Wear complete body protection.	Safe66 2012-06
	Become trained and read the instructions before working on the machine or welding.	Safe65 2012-06

### 3-2. Miscellaneous Symbols And Definitions

<b>A</b>	Amperes
<b>V</b>	Volts
<b>≡</b>	Direct Current (DC)
<b>IP</b>	Degree Of Protection
	Slow
	Increase
	Gas In
	Process
<b>t</b>	Time
	Trigger Hold Off Indicator Light
	Output
	Fast

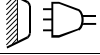
	Program
	Variable Inductance
	Trigger Hold On Indicator Light
	Wire Feed
	Cold Jog (Inch) Towards Workpiece
	Circuit Breaker
	Trigger Hold On
<b>U<sub>1</sub></b>	Primary Voltage
	Sequence
	Trigger Control
<b>X</b>	Duty Cycle
	Input

	Constant Current
	Trigger Hold Off
	Read Instructions
<b>I<sub>1</sub></b>	Primary Current
	Wire Type
	Arc Control
	Gas Type
<b>3</b> 	Three Phase
	Line Connection
<b>1</b> 	Single Phase
	Filter

# SECTION 4 – SPECIFICATIONS

## 4-1. Serial Number And Rating Label Location

The serial number and rating information for this product is located inside the door. Use rating label to determine input power requirements and/or rated output. For future reference, write serial number in space provided on back cover of this manual.

## 4-2. Unit Specifications

Type of Input Power	Welding Power Source Type	Wire Feed* Speed Range	Wire Diameter Range	Input Welding Circuit Rating	Max. Wire Spool Capacity	Overall Dimensions	Weight
24 Volts AC Single Phase 10 Amperes 50/60 Hz	Constant Voltage (CV) DC With 14-Pin And Contactor Control	50 to 700 ipm (1.3 To 17.8 mpm)	Solid Wire: .023 - .052 in. (0.6 To 1.3 mm)  Flux Cored: .030 - 5/64 in. (0.8 To 2 mm)	100 Volts, 425 Amperes, 60% Duty Cycle	45 lb (20.4 kg), 12 in. (304 mm)	Length: 21 in. (533 mm) Width: 9 in. (229 mm) Height: 15-1/2 in. (394 mm)	31 lb (14.1 kg)
*Rated Speed Range Per IEC - 60974-5							

## 4-3. Environmental Specifications

### A. IP Rating

IP Rating
IP23
This equipment is designed for outdoor use. It may be stored, but is not intended to be used for welding outside during precipitation unless sheltered.
IP23 2014-06

## 4-4. 14-Pin Plug Information

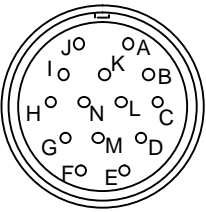
 REMOTE 14	Pin*	Pin Information
	A	24 volts AC with respect to socket G.
	B	Contact closure to A completes 24 volts AC contactor control circuit.
	G	Circuit common for 24 volts AC circuit.
	C	+10 volts DC input from power source to wire feeder with respect to socket D.
	D	Remote control circuit common.
	E	0 to +10 volts DC output signal from wire feeder to power source with respect to socket D.
	H	Voltage feedback; 0 to +10 volts DC, 1 volt per 10 arc volts.
	F	Current feedback; 0 to +10 volts DC, 1 volt per 100 amperes.
*The remaining pins are not used.		

## 4-5. Gun Recommendation Table

Process	Gun
GMAW – Hard or Cored Wires	Bernard Q-Gun Tregaskiss Tough Gun Roughneck C-Series
FCAW – Self-Shielding Wires	Bernard Dura-Flux Gun Ironmate Series







## 5-3. Connecting Welding Gun

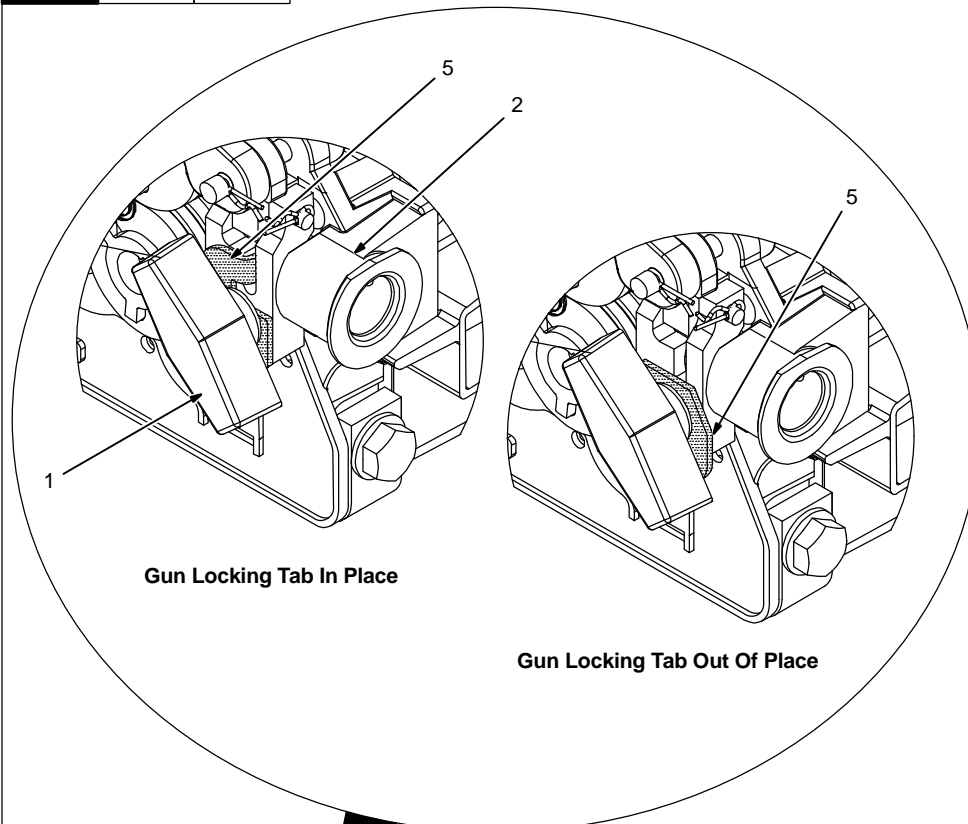

Gun Locking Tab In Place

Gun Locking Tab Out Of Place

**⚠ Turn Off wire feeder and welding power source. Stop engine on welding generator.**

- 1 Gun Securing Knob
- 2 Gun Block
- 3 Gun Power Pin
- 4 Power Pin Groove
- 5 Gun Locking Tab

Loosen gun securing knob, insert gun power pin into gun block. Position power pin as close as possible to drive rolls without touching. Align the gun power pin groove with the gun locking tab. Tighten gun securing knob.

If the gun power pin does not have a groove, loosen knob to rotate the gun locking tab 180 degrees. This prevents the gun locking tab from interfering with the gun power pin when inserted into the gun block. Insert the gun power pin into the gun block. Position power pin as close as possible to drive rolls without touching them. Tighten gun securing knob.

- 6 Gun Trigger Plug
- 7 Gun Trigger Receptacle

Connect gun trigger plug to gun trigger receptacle.

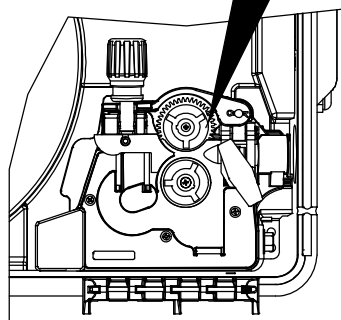

Internal Side View

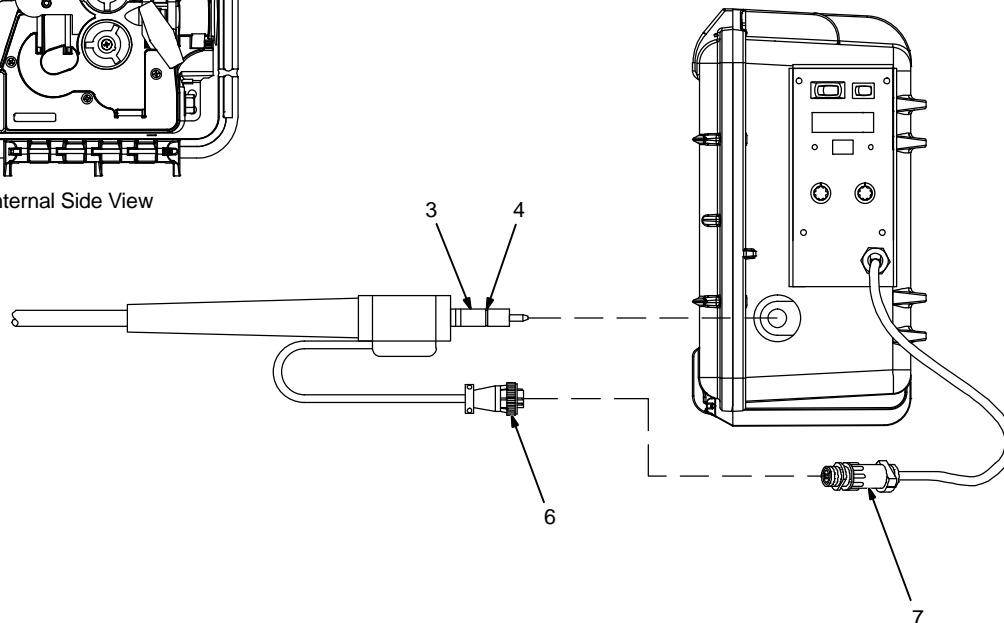

## 5-4. Connecting Shielding Gas

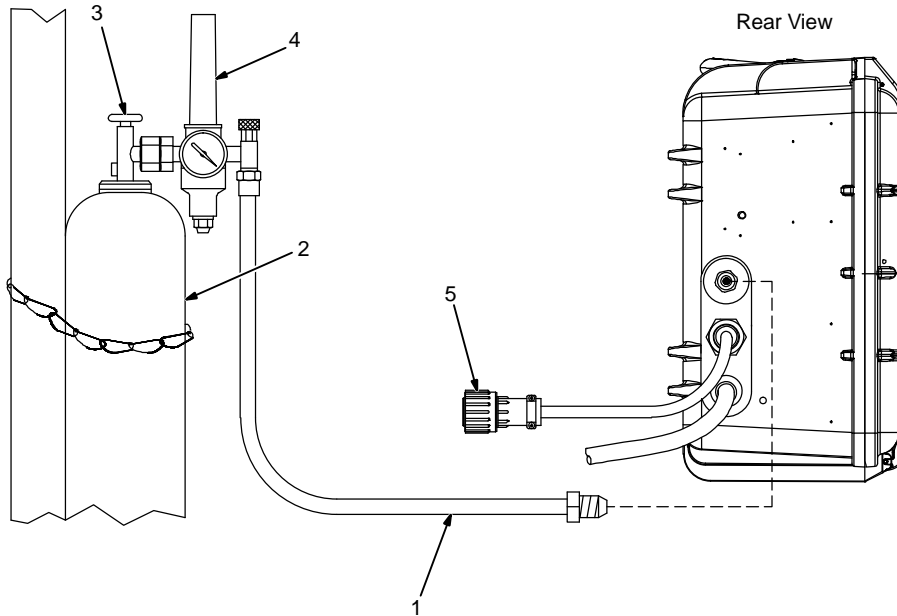
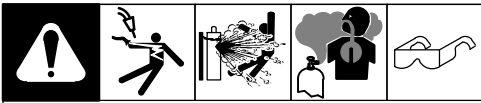

**NOTICE** – This feeder has a shielding gas filter that requires special attention when cleaning. See Section 7-3 for proper cleaning instructions.

- 1 Gas Hose With 5/8-18 Right-hand Thread Fittings (Customer Supplied)

**Tighten** gas hose fitting to a maximum of 100 in. lb (12 N·m).

- 2 Shielding Gas Cylinder

**Shielding gas pressure not to exceed 100 psi (689 kPa).**

- 3 Valve

- 4 Flowmeter

- 5 14-Pin Plug

Close valve on cylinder when finished welding.

263 836-A

## 5-5. Connecting Weld Cable

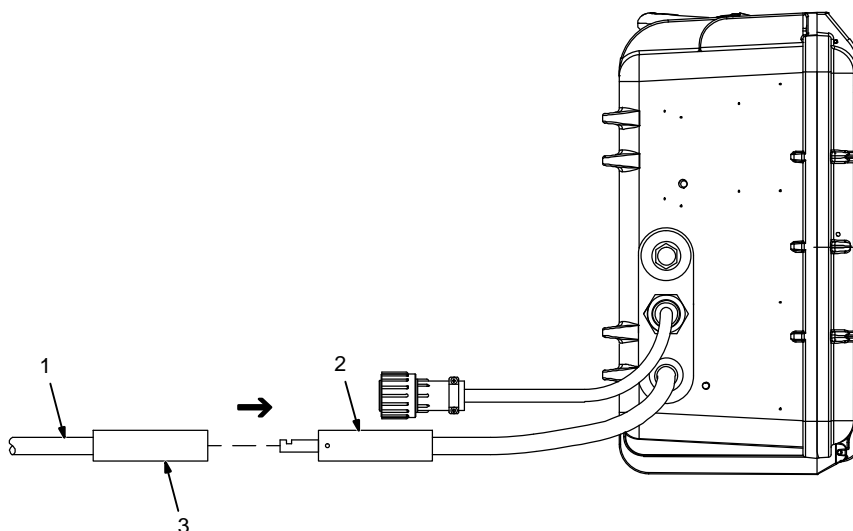

**Turn Off** wire feeder and welding power source. Stop engine on welding generator.

- 1 User-Supplied Weld Cable

Follow wire manufacturer's recommendations for weld cable polarity.

- 2 Male Connector

- 3 User-Supplied Female Connector

Connect male and female connectors.

263 837-A

## 5-6. Selecting Cable Sizes\*

 Turn off power before connecting to weld output terminals.

 Do not use worn, damaged, undersized, or repaired cables.

**NOTICE** – The Total Cable Length in Weld Circuit (see table below) is the combined length of both weld cables. For example, if the power source is 100 ft (30 m) from the workpiece, the total cable length in the weld circuit is 200 ft (2 cables x 100 ft). Use the 200 ft (60 m) column to determine cable size.

Welding Amperes	Weld Cable Size** and Total Cable (Copper) Length in Weld Circuit Not Exceeding***							
	100 ft (30 m) or Less		150 ft (45 m)	200 ft (60 m)	250 ft (70 m)	300 ft (90 m)	350 ft (105 m)	400 ft (120 m)
	10 – 60% Duty Cycle AWG (mm <sup>2</sup> )	60 – 100% Duty Cycle AWG (mm <sup>2</sup> )	10 – 100% Duty Cycle AWG (mm <sup>2</sup> )					
100	4 (20)	4 (20)	4 (20)	3 (30)	2 (35)	1 (50)	1/0 (60)	1/0 (60)
150	3 (30)	3 (30)	2 (35)	1 (50)	1/0 (60)	2/0 (70)	3/0 (95)	3/0 (95)
200	3 (30)	2 (35)	1 (50)	1/0 (60)	2/0 (70)	3/0 (95)	4/0 (120)	4/0 (120)
250	2 (35)	1 (50)	1/0 (60)	2/0 (70)	3/0 (95)	4/0 (120)	2x2/0 (2x70)	2x2/0 (2x70)
300	1 (50)	1/0 (60)	2/0 (70)	3/0 (95)	4/0 (120)	2x2/0 (2x70)	2x3/0 (2x95)	2x3/0 (2x95)
350	1/0 (60)	2/0 (70)	3/0 (95)	4/0 (120)	2x2/0 (2x70)	2x3/0 (2x95)	2x3/0 (2x95)	2x4/0 (2x120)
400	1/0 (60)	2/0 (70)	3/0 (95)	4/0 (120)	2x2/0 (2x70)	2x3/0 (2x95)	2x4/0 (2x120)	2x4/0 (2x120)

\* This chart is a general guideline and may not suit all applications. If cable overheats, use next size larger cable.

\*\*Weld cable size (AWG) is based on either a 4 volts or less drop or a current density of at least 300 circular mils per ampere.  
( ) = mm<sup>2</sup> for metric use

\*\*\*For distances longer than those shown in this guide, call a factory applications rep. at 920-735-4505 (Miller) or 1-800-332-3281 (Hobart).

Ref. S-0007-L 2015-02

## Notes

## 5-7. Installing And Threading Welding Wire

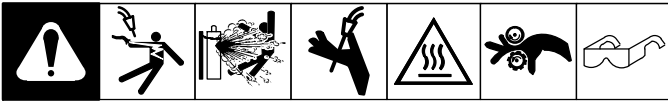

☞ Hold wire tightly to keep it from unraveling.

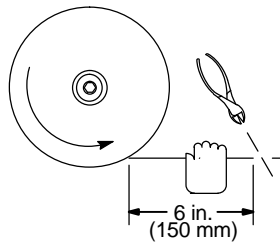
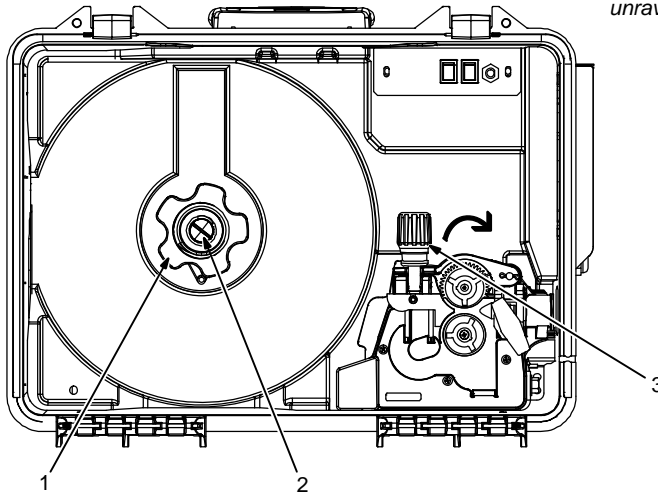

Pull and hold wire; cut off end.

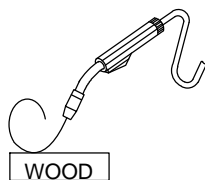

Tighten  
Clockwise

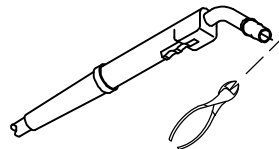
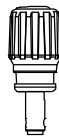

### Installing Wire And Adjusting Hub Tension:

- 1 Retaining Nut
- 2 Hub Tension Adjustment Knob

Remove retaining nut, and install spool so hub pin fits spool hole. Reinstall retaining nut.

Adjust tension knob so only a slight force is needed to turn spool.

☞ Do not over tighten tension knob. It is not necessary to use any tools to tighten the knob.

### Threading Welding Wire:

- 3 Pressure Adjustment Knob

Lay gun cable out straight.

Open pressure assembly. Hold wire tightly and cut off end. Guide wire through alignment pins, through drive rolls, and into gun.

Close pressure assembly and tighten pressure adjustment knob enough to feed wire. Press jog switch until wire comes out of gun.

To set proper drive roll pressure, release the pressure on the drive rolls by loosening the pressure adjustment knob. Position gun at about a 45 degree angle, with nozzle about two inches from a wooden surface. While feeding the wire against the wooden surface, increase the pressure to one half turn past the point where the wire stops slipping. If the wire slips at maximum hand-tight pressure, there may be other problems. Check the gun liner, spool tension, contact tip and drive roll wear, as all these can cause wire feeding problems.

Cut off wire, and close door.

263 838-A

# SECTION 6 – OPERATION

## 6-1. Controls

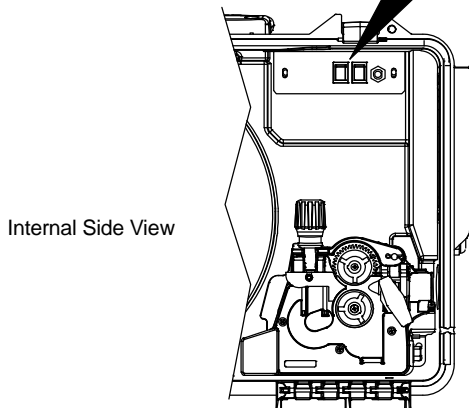
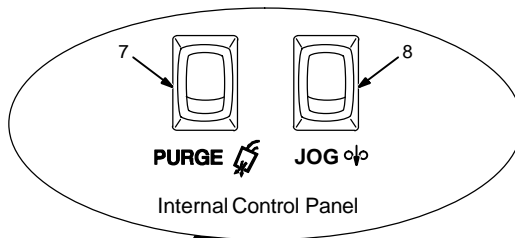
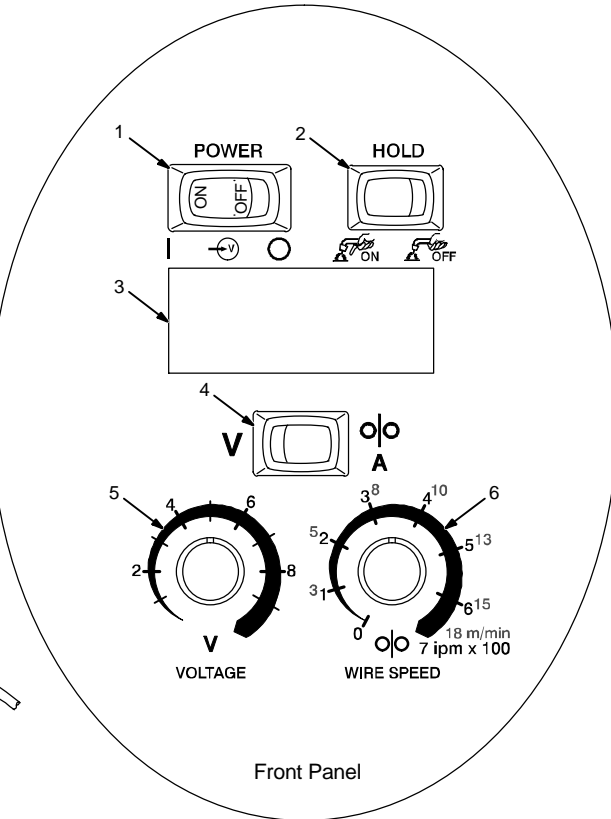
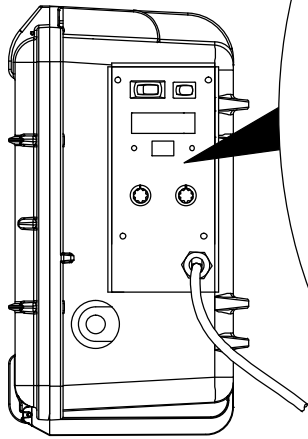
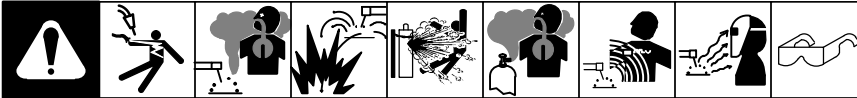

- 1 Power Control Switch
- 2 Trigger Hold Switch (If applicable)

Depress the switch to On to weld without holding gun trigger throughout the weld cycle.

To start weld, press and release gun trigger. To end weld, press and release gun trigger.

Depress the switch to Off to turn trigger hold Off.

- 3 Meter Display (If applicable)
- 4 Volts, Wire Feed Speed Or Amps Select Switch (If applicable)

Meter is factory set to display voltage and wirefeed speed. To display voltage and amps refer to Section 6-2 for DIP switch settings.

- 5 Voltage Control
- 6 Wire Speed Control

Use control to adjust wire speed.

- 7 Purge Switch

Press switch to momentarily energize gas solenoid and purge air from gun, and to adjust shielding gas regulator.

- 8 Jog Switch

Use Jog position to momentarily feed welding wire at speed set on Wire Speed control without energizing welding circuit or shielding gas valve.

Close and latch door.

## 6-2. Setting Digital Meter Board PC4 DIP Switches

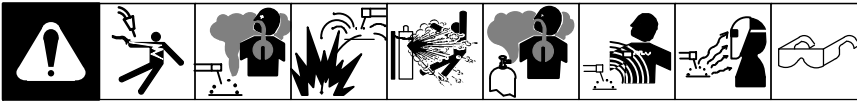

- 1 Front Meter Panel
- 2 S1 DIP Switch
- 3 S2 DIP Switch

If the DIP switches are set to a Meter Hold (ON) position, the meter value will hold 5 seconds after gun is triggered. The meter value will continue to hold for 8 seconds after trigger is released or until gun is re-triggered.

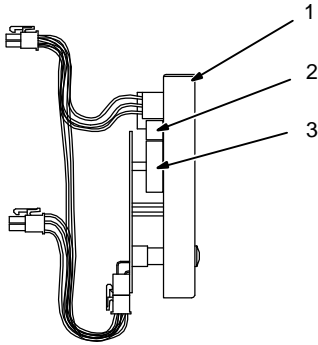

Meter DIP switches are factory set to display voltage using 14-pin feedback. Meter hold feature is factory set to off position.

- Shows switch in ON/DOWN (closed) position.
- Shows switch in OFF/UP (open) position.
- Shows switch does not affect this function.

### Wire Speed Settings

**Wire Speed In Inches Per Minute**

S1: Switch 1 is ON (shaded), Switch 2 is OFF (unshaded).

S2: Switch 1 is OFF (unshaded), Switch 2 is ON (shaded), Switch 3 is OFF (unshaded), Switch 4 is OFF (unshaded), Switch 5 is OFF (unshaded).

**Wire Speed In Meters Per Minute**

S1: Switch 1 is ON (shaded), Switch 2 is OFF (unshaded).

S2: Switch 1 is OFF (unshaded), Switch 2 is ON (shaded), Switch 3 is OFF (unshaded), Switch 4 is OFF (unshaded), Switch 5 is OFF (unshaded).

### Voltage Display Settings

**Display Volts Using Sense Lead**

S1: Switch 1 is OFF (unshaded), Switch 2 is OFF (unshaded).

S2: Switch 1 is ON (shaded), Switch 2 is OFF (unshaded), Switch 3 is OFF (unshaded), Switch 4 is OFF (unshaded), Switch 5 is OFF (unshaded).

**Display Volts Using 14-Pin**

S1: Switch 1 is OFF (unshaded), Switch 2 is OFF (unshaded).

S2: Switch 1 is ON (shaded), Switch 2 is OFF (unshaded), Switch 3 is OFF (unshaded), Switch 4 is OFF (unshaded), Switch 5 is OFF (unshaded).

### Amperage Display Settings

**Display Amps Using Current Sensor**

S1: Switch 1 is OFF (unshaded), Switch 2 is OFF (unshaded).

S2: Switch 1 is OFF (unshaded), Switch 2 is ON (shaded), Switch 3 is OFF (unshaded), Switch 4 is OFF (unshaded), Switch 5 is OFF (unshaded).

**Display Amps Using 14-Pin**

S1: Switch 1 is OFF (unshaded), Switch 2 is OFF (unshaded).

S2: Switch 1 is OFF (unshaded), Switch 2 is ON (shaded), Switch 3 is OFF (unshaded), Switch 4 is OFF (unshaded), Switch 5 is OFF (unshaded).

### Meter Hold Settings

**Meter Hold ON**

S1: Switch 1 is OFF (unshaded), Switch 2 is ON (shaded).

S2: Switch 1 is OFF (unshaded), Switch 2 is OFF (unshaded), Switch 3 is OFF (unshaded), Switch 4 is OFF (unshaded), Switch 5 is OFF (unshaded).

**Meter Hold OFF**

S1: Switch 1 is OFF (unshaded), Switch 2 is OFF (unshaded).

S2: Switch 1 is OFF (unshaded), Switch 2 is OFF (unshaded), Switch 3 is OFF (unshaded), Switch 4 is OFF (unshaded), Switch 5 is OFF (unshaded).

## 6-3. Setting DIP Switches For Timer Models

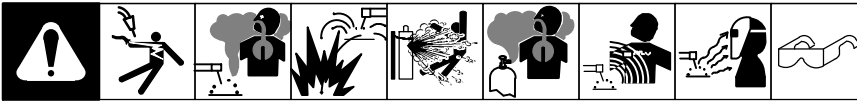

### DIP SWITCH SETTINGS

Set DIP Switch S1 on PC50 for desired operation.

Showing DIP switch setting as indicates it has no affect on that particular function.

#### Factory default settings:



#### Preflow settings:

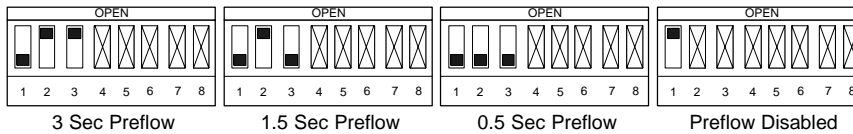

#### Burnback settings:

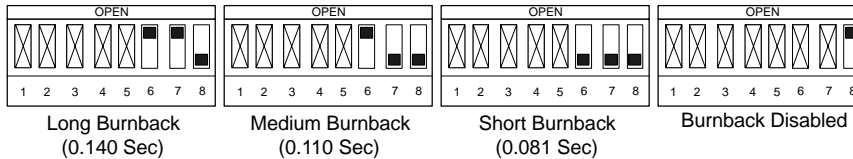

#### Postflow settings:

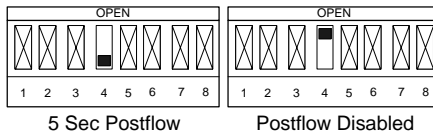

#### Re-Trigger settings:

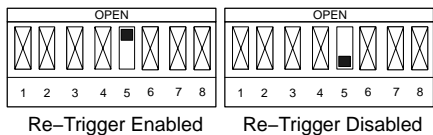

With Re-Trigger enabled: If trigger is pulled within 3 seconds of trigger release, feeder will skip Preflow and go directly to Weld portion of the weld sequence. If trigger is pulled after 3 seconds, feeder will go directly to Preflow portion of the weld sequence.

### OPERATION

The normal weld sequence for this feeder is: pull trigger, feeder goes into 1.5 seconds of preflow, after preflow feeder will be in weld, release trigger, feeder will be in 5 seconds of postflow. However, the preflow portion of the sequence will be skipped, if the feeder is re-triggered within 3 seconds of releasing the trigger. If more than 3 seconds passes before the feeder is re-triggered, the feeder weld sequence starts with 1.5 seconds of preflow.



# SECTION 7 – MAINTENANCE & TROUBLESHOOTING

## 7-1. Routine Maintenance

					<b>Disconnect power before maintaining.</b>		<i>Maintain more often during severe conditions.</i>	
<b>3 Months</b>								
Replace Damaged Or Unreadable Labels			Replace Damaged Gas Hose					
Repair Or Replace Cracked Cables And Cords								
<b>6 Months</b>								
Clean Drive Rolls			Blow Out Or Vacuum Inside					

## 7-2. Overload Protection And Thermostat Protection

				<b>Turn Off wire feeder and welding power source. Stop engine on welding generator.</b>				
Internal Side View 				1 Supplementary Protector CB1 CB1 protects wire feeder from overload. Correct problem and reset CB1. Close and latch door.				
				<b>Thermostat Protection</b> Unit has internal thermostat protection on bus bar and will not energize contactor in welding power source when overheating occurs. (see Section 7-4).				

263 838-A

### 7-3. Cleaning Debris From Shielding Gas Filter Fitting

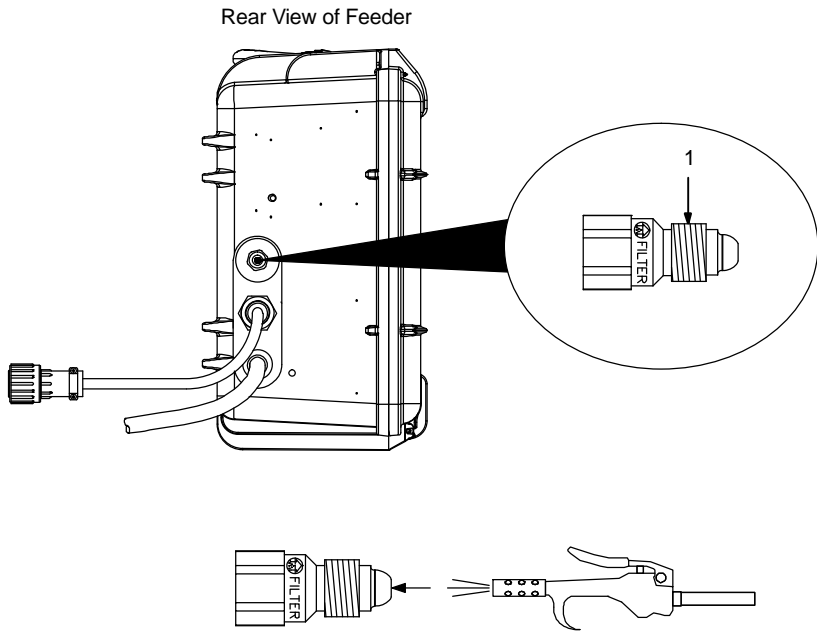

Rear View of Feeder

**⚠ Disconnect power before maintaining.**

1 Shielding Gas Filter Fitting

Remove fitting from gas valve on back panel of feeder.

Blow compressed air through the threaded male end of fitting to dislodge debris from internal mesh screen.

*☞ if blowing compressed air through fitting does not clear obstructions replace fitting.*

Reinstall fitting into gas valve.

Tighten fitting to 250 in. lbs (28 N-m).

Tools Needed:

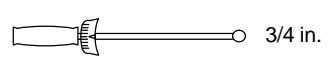

3/4 in.

Ref. 263 836-A / 256 623-A

### 7-4. Troubleshooting

Trouble	Remedy
Wire does not feed, unit completely inoperative.	Turn Power switch On.
	Check 14-pin plug PLG2 connections.
	Check input power.
Wire does not feed.	Check supplementary protector CB1. (see Section 7-2).
	Check gun trigger connection at wire feeder. Check gun trigger leads and trigger switch. See gun Owner's Manual.
	Have Factory Authorized Service Agent check drive motor and control board PC1.
Wire feeds erratically.	Readjust hub tension (see Section 5-7).
	Readjust drive roll pressure.
	Clean or replace dirty or worn drive roll (see Section 5-2).
	Remove weld spatter around nozzle opening.
	Replace contact tip or liner. See gun Owner's Manual.
	Change to correct size and type drive roll (see Section 5-2).
Have Factory Authorized Service Agent check control board PC1.	
Wire feeds when Jog switch is pressed but not when gun trigger is pressed.	Check gun trigger connection at wire feeder. Check gun trigger leads and trigger switch. See gun Owner's Manual.
Wire feeds as soon as power is applied.	Check gun trigger. See gun Owner's Manual.





# SECTION 8 – ELECTRICAL DIAGRAMS

 <b>ELECTRIC SHOCK HAZARD</b>	<b>WARNING</b>
	<ul style="list-style-type: none"> <li>• Do not touch live electrical parts.</li> <li>• Disconnect input power or stop engine before servicing.</li> <li>• Do not operate with covers removed.</li> <li>• Have only qualified persons install, use, or service this unit.</li> </ul>

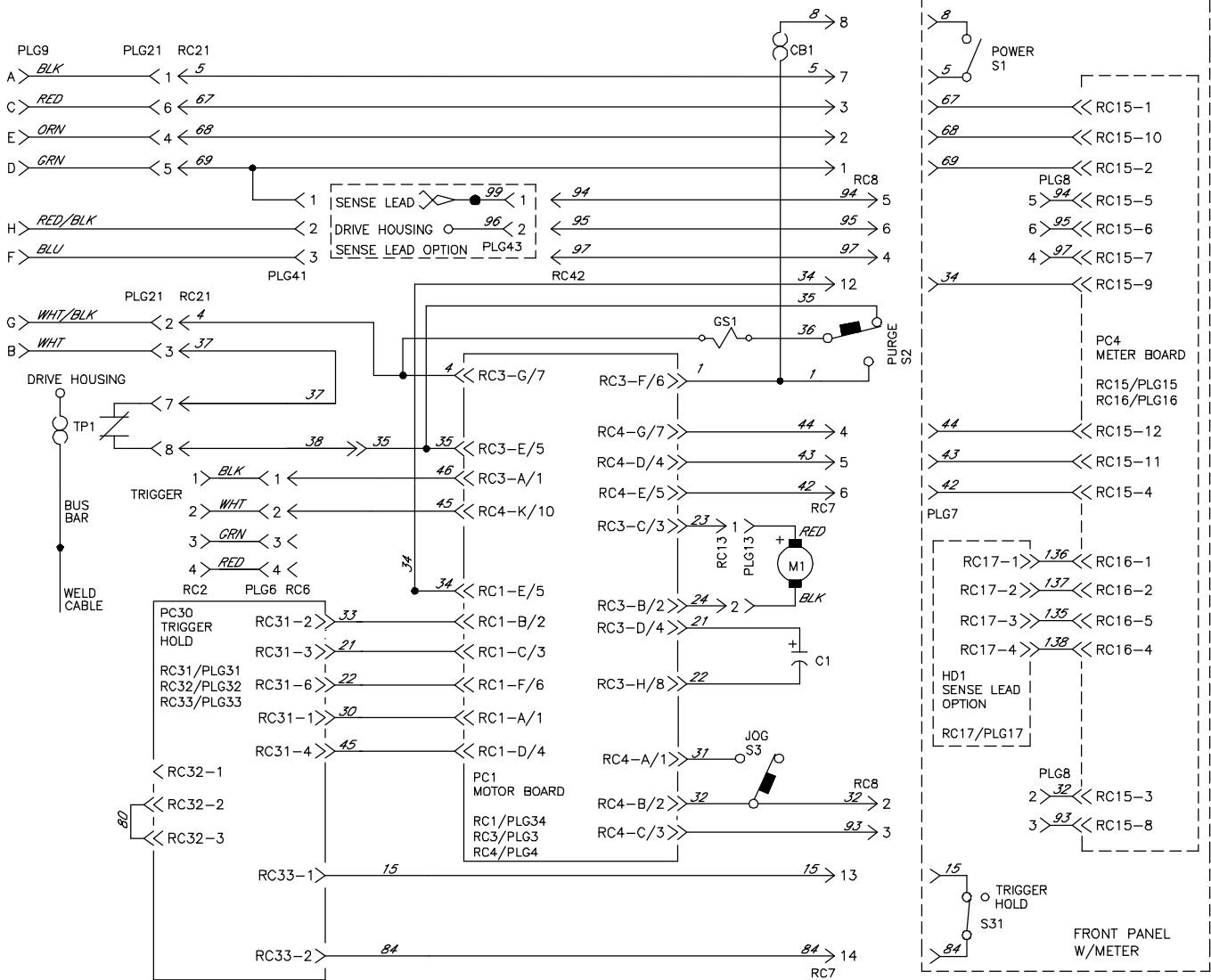



Figure 8-1. Circuit Diagram For Wire Feeder

 <b>ELECTRIC SHOCK HAZARD</b>	<b>WARNING</b> <ul style="list-style-type: none"> <li>Do not touch live electrical parts.</li> <li>Disconnect input power or stop engine before servicing.</li> <li>Do not operate with covers removed.</li> <li>Have only qualified persons install, use, or service this unit.</li> </ul>

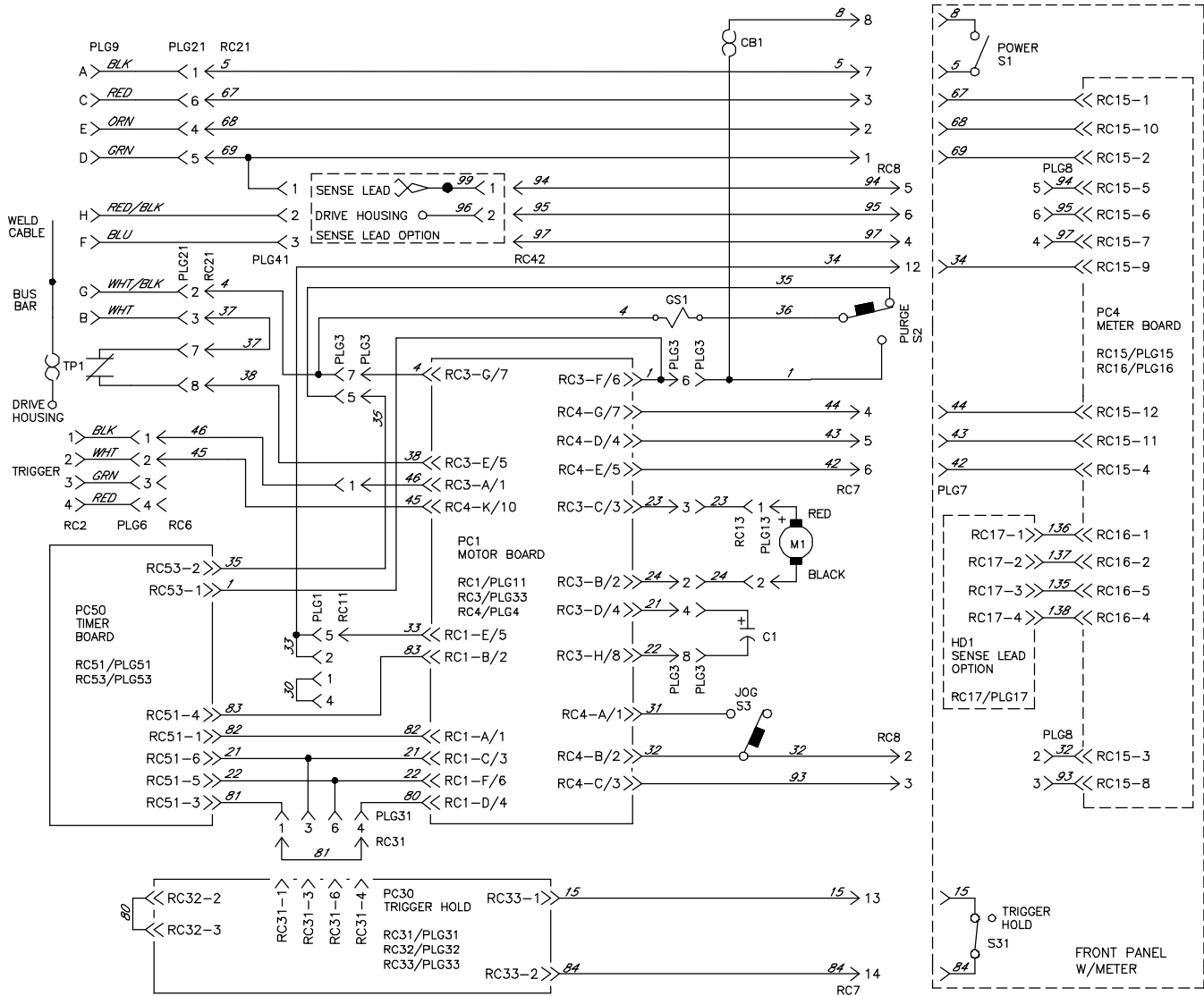

Figure 8-2. Circuit Diagram For Wire Feeder (w/Timer PCB Board)



# SECTION 9 – PARTS LIST

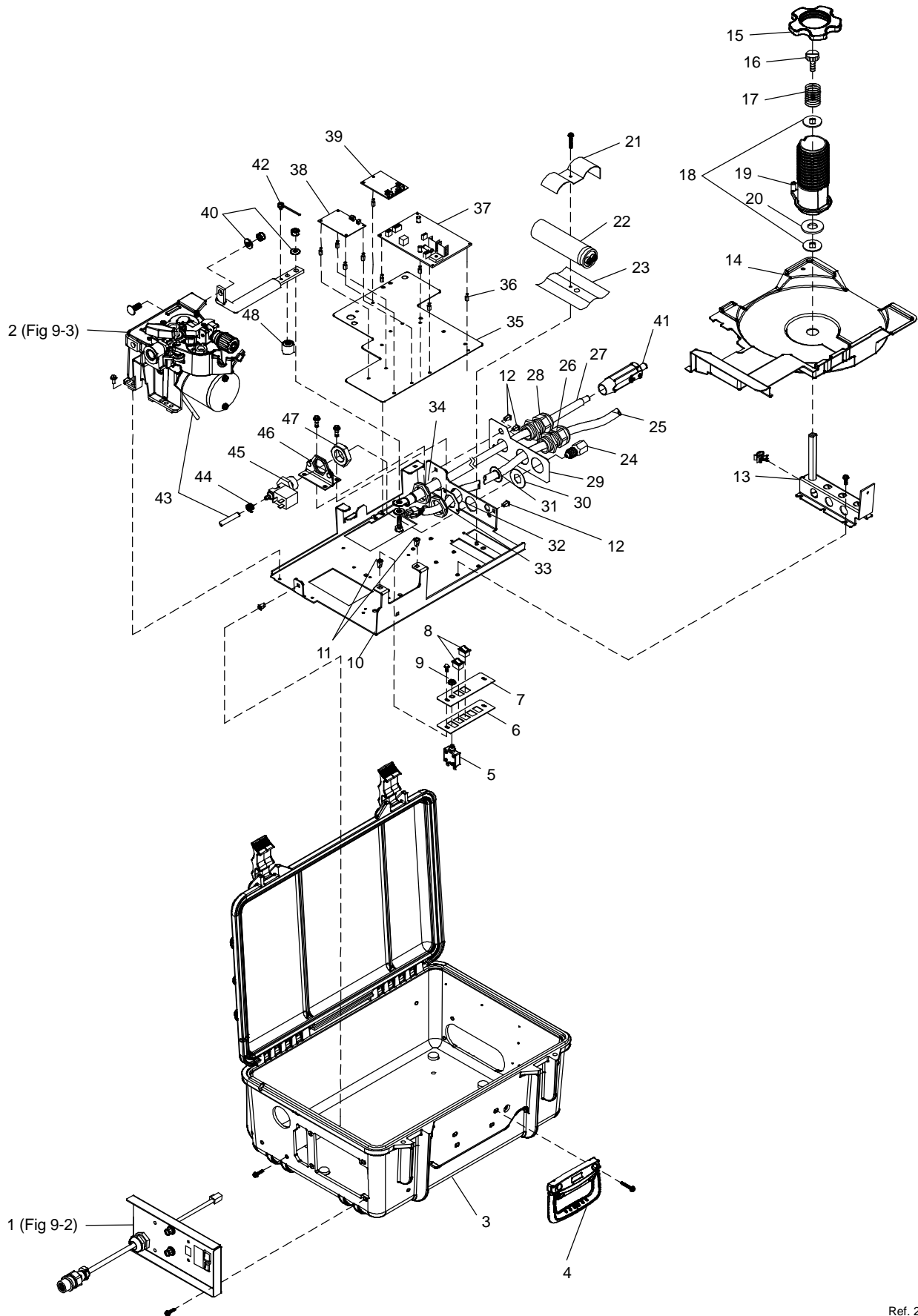

Figure 9-1. Complete Assembly



Item No.	Diagram marking	Part No.	Description	Quantity
----------	-----------------	----------	-------------	----------

**Figure 9-1. Complete Assembly**

1		Fig 9-2	Panel Assembly Front	1
2		Fig 9-3	Drive Assembly, Wire	1
3		252170	Case, Control Feeder Machined Blk Sc	1
3		268977	Case, Control Feeder (Timer Model)	1
4		208015	Handle, Rubberized Carrying	1
5	CB1	083432	Supplementary Pro, Man Reset 1P 10A 250VAC Frict	1
6		255703	Panel, Inner	1
7		262587	Plate, Inner	1
8	S2, S3	237328	Switch, Rocker Spdt 12A 125VAC On-None-(On) .187T	2
9		147195	Nut, 375-27 .54Hex .25H Nyl Flange .62D	1
10		252177	Chassis, Control Box	1
11		256594	Grommet, Scr No 8/10 Panel Hole .309X.315 .125H	2
12		256595	Grommet, Scr No 8/10 Panel Hole .270X.290 .062H	6
13		222103	Support, Spool	1
14		252186	Shroud, Wire	1
15		235607	Nut, Hub	1
16		237843	Knob, Brake Adjust	1
17		172918	Spring	1
18		231211	Washer, Anti-Turn	2
19		235608	Hub, Spool 12 Inch	1
20		058424	Washer, Fiber (Brake)	1
21		210133	Bracket, Capacitor Support SC12	1
22	C1	177360	Capacitor, Elctlt 20000 UF 45 VDC Can 1.40 Dia.	1
23		207678	Insulator, Capacitors	1
24		211989	Fitting, W/Screen	1
25		263280	Cable, Power (Includes)	17 in.
		079739	Conn, Circ Cpc Clamp Str Rlf Size 17-20 .703 Od	1
		600797	Cable, Port No 16 8/C Type Soow Rb Jkt	1.4 ft
	PLG9	141162	Housing Plug+Pins, (Service Kit)	As Rqd
	PLG21	115092	Housing Plug+Pins, (Service Kit)	As Rqd
	PLG41	131204	Housing Plug+Pins, (Service Kit)	As Rqd
26		139041	Bushing, Strain Relief .450/.709 Id X1.115 Mtg Hole	1
27		221346	Weld Cable Assembly, 4/0 (Includes)	1
		600324	Cable, Weld Cop Strd No 4/0 Ep Rubber Jacket 600V	22 in.
		009800	Term, Ring Tng 375 Stud Solistrand 4/0	1
28		215980	Bushing, Strain Relief .709/.984 Id X1.375 Mtg Hole	1
29		262418	Insulator, Rear Panel	1
30		252196	Bushing Gas Valve Opening	1
31		264951	Washer, Flat 1.125 Idx1.281 Odx.090T 6061 Al	1
32		263707	Spacer, 14-Pin Strain Relief	1
33		254843	Nut, Pg21 1.50Hex X .375H Aluminum	1
34		234126	Nut, Conduit 1.000 Npt Knurled	1
35		262420	Insulator, Motor	1
36		097132	Stand-Off, No 6-32 X .375 Lg .250 Hex Brs M&F	8
36		097132	Stand-Off, No 6-32 X .375 Lg .250 Hex Brs M&F (w/Timer PCB Board)	12
37	PC1	262423	Circuit Card Assy, Motor Speed Control	1
38	PC30	236780	Circuit Card Assy, Trigger Hold/Burnback (R)	1
39	PC50	250505	Circuit Card Assy, Timer Pre/Post/Bb Re-Trigger (Timer Model Only)	1
40		183387	Washer, Cone .380idx .860odx.109T Stl Pld 4000Lbs	2
41		242250	Conn, TW LK Insul Male (Twyco/Lenco Type) HD 3/0-4/0	1
42	TP1	230471	Thermostat, Nc Open 140C Close 110C Snap Action	1
43		134834	Hose, SAE .187 Id X .410 Od XCoil	22 in.
44		149332	Clamp, Hose .405 - .485 Clp Dia Slftrng Olive Dra	1
45	GS1	228036	Valve, 24VAC 1Way .750-14 Thd 2.0MM Orf 100 PSI	1
46		252254	Bracket, Gas Valve	1
47		220805	Nut, 750-14 Knurled 1.68Dia .41H Nyl	1
48		026947	Stand-Off, Insul .250-20 X 1.000 Lg X .312 Thd	1
		252393	Label, Warn Gen Precaution Suitcase CE/Domestic	1
		196956	Label, Warning Electric Shock And Pinch Wordless	1
		252538	Label, Warning/Miller/12RC Side	2
	PLG1	115093	Housing Plug+Skts, (Service Kit)	1
	PLG3	115092	Housing Plug+Skts, (Service Kit)	1
	PLG4	115091	Housing Plug+Skts, (Service Kit)	1



☞ Hardware is common and not available unless listed.

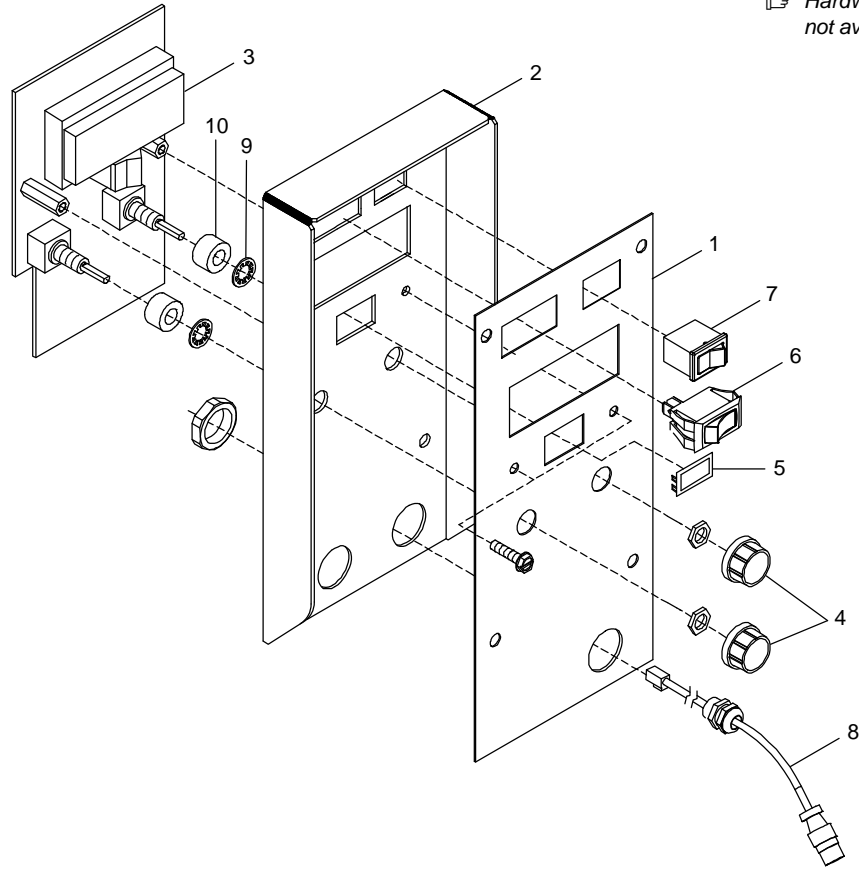

Ref. 264 188-A

**Figure 9-2. Front Panel Assembly with Meters**

Item No.	Dia. Mkgs	Part No.	Description	Quantity
----------	-----------	----------	-------------	----------

**Figure 9-2. Front Panel Assembly with Meters (Figure 9-1 Item 1)**

.. 1			Nameplate (Order By Model And Serial Number)	1
.. 2		263244	Panel, Front	1
.. 3	PC4	236698	Circuit Card Assy, Meter W/Amps (R)	1
.. 4		239822	Knob, Pointer .840 Dia X .125 Id Push On W/Spring	2
.. 5		133644	Frame, Snap-In Switch Rocker Panel Mtg	1
.. 6	S1	267296	Switch, Rocker SPST 15A 250VAC On-Off Visi Red Rock	1
.. 7	S31	217932	Switch, Rocker SPST .4VA 28VDC On-None-Off .187 Ter	1
.. 8		252262	Cable, Trigger 25 In Dual Schedule W/Strain Relief (Includes)	1
		139042	Bushing, Strain Relief .270/.470 Id X .804 Mtg Hole	1
	PLG6	115094	Housing Plug+Skts, (Service Kit)	1
		079531	Conn, Circ Cpc Clamp Str Rlf Size 11 .453 Od	1
	RC2	080328	Rcpt W/Skts, Free Hanging	1
		604571	Cable, Port No 18 4/C Type Sjo Nprn Jkt Re	1
.. 9		602209	Washer, Tooth.256 Idx0.478 Odx.028T Stl Pld Int.250 A	2
.. 10		251133	Spacer, Nylon .500 Od X .257 Id X .312 Lg	2

**To maintain the factory original performance of your equipment, use only Manufacturer's Suggested Replacement Parts. Model and serial number required when ordering parts from your local distributor.**

☞ Hardware is common and not available unless listed.

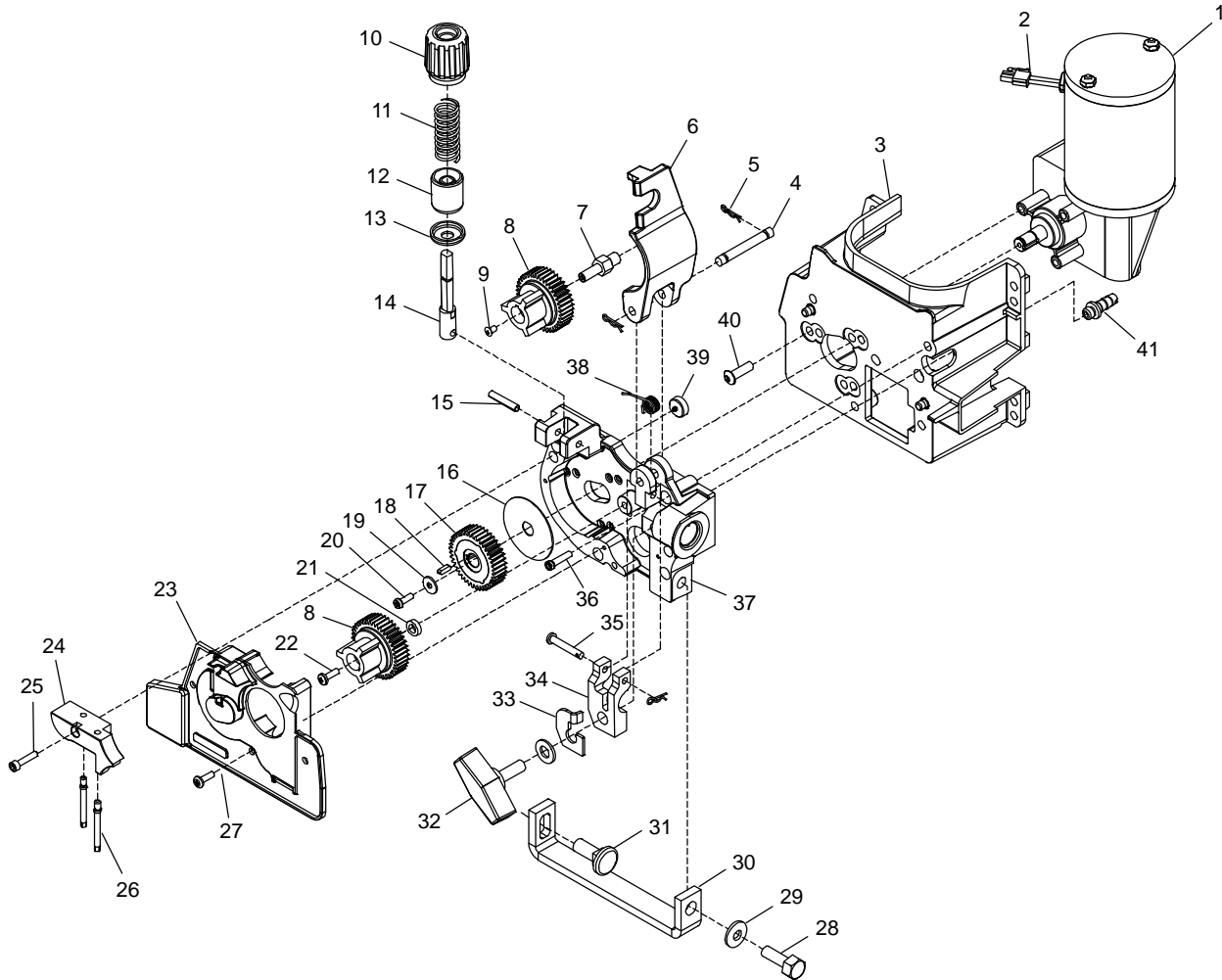

Figure 9-3. Drive Assembly, Wire

Item No.	Dia. Mkgs	Part No.	Description	Quantity
----------	-----------	----------	-------------	----------

**Figure 9-3. Drive Assembly, Wire (Figure 9-1 Item 2)**

1	M1	252214	Motor, Right Angle 24VDC	1
2	PLG4	131054	Housing Plug+Skts, (Service Kit)	1
3		252229	Insulator, Motor/Drive/Tach	1
4		079634	Pin, Hinge	1
5		151828	Pin, Cotter Hair .042 X .750	3
6		252235	Lever, Mtg Pressure Gear Machined	1
7		252238	Stand-Off, Drive Roll Carrier	1
8		172075	Carrier, Drive Roll W/Components 24 Pitch	2
9		228562	Screw, 006-32x .25 Pan Hd-Phl W/Ext Washer (Sems) Stl	1
10		196895	Knob, Pressure	1
11		252243	Spring, Cprsn Big	1
12		241856	Cup, Spring	1
13		085244	Washer, Cupped .328idx .812odx16gax.125 Lip	1
14		267899	Fastener, Pinned Machined	1
15		010224	Pin, Spring Cs .187 X 1.000	1
16		252230	Grommet, Motor Shaft	1
17		252786	Drive, Pinion 10mm Shaft	1
18		252220	Key, Stl 3mm/3mm X 10mm	1
19		602237	Washer, Flat .172idx0.500od X .048t Stl Pld Blk	1
20		174609	Screw, M 4- .7x 12 Cheese Hd Blk Din 84	1
21		166072	Spacer, Gear	1
22		273794	Screw, 250-20x1.38 Soc Hd-Hex Gr8 Pln	1
23		252785	Cover, Gear	1
24		252322	Block, Wire Inlet Guide	1
25		253404	Screw, 008-32x .75 Soc Hd-Hex Stl Pld Lkg Patch	1
26		252323	Pin, Wire Inlet Guide	2
27		258838	Screw, 008-32x .37 Pan Hd-Phl Stl Pld Zc Lkg Patch	3
28		601965	Screw, 375-16x1.00 Hex Hd-Pln Gr5 Pld Blk	1
29		183387	Washer, Cone .380idx .860odx.109t Stl Pld 4000lbs	1
30		252218	Bus Bar, Drive Housing	1
31		252232	Bolt, Crg Stl .375-16 X 1.000 Gr5 Pl Fhsh	1
32		124778	Knob, T 2.000 Bar W/.312-18 Stud 1.000 Lg Plstc	1
33		237188	Lock, Pin Power	1
34		234074	Clamp, Pin Power	1
35		234073	Pin, Hinge	1
36		252222	Screw, 010-32x .75 Soc Hd-Hex Stl Gr8 Pld Lkg Patch	4
37		253513	Housing, Wire Drive	1
38		222159	Spring, Torsion	1
39		253655	Insulator, Screw Motor	3
40		174610	Screw, M 6-1.0x 20 Soc Hd Button Cap Blk	3
41		144172	Ftg, Hose Brs Barbed M 3/16 TBG X .250-20	1

**To Maintain The Factory Original Performance Of Your Equipment, Use Only Manufacturer'S Suggested Replacement Parts. Model And Serial Number Required When Ordering Parts From Your Local Distributor.**

**Table 9-1. Drive Roll & Inlet Guide**

☞ Base selection of drive rolls upon the following recommended usages:

1. V-Grooved rolls for hard wire.
2. U-Grooved rolls for soft and soft shelled cored wires.
3. U-Cogged rolls for extremely soft shelled wires (usually hard surfacing types).
4. V-Knurled rolls for hard shelled cored wires.
5. Drive roll types may be mixed to suit particular requirements (example: V-Knurled roll in combination with U-Grooved).

Wire Diameter			Drive Roll (2 Required)		Inlet Wire Guide
Fraction	Decimal	Metric	Part No.	Type	
.023/.025 in.	.023/.025 in.	0.6 mm	087130	V-Grooved	221030
.030 in.	.030 in.	0.8 mm	053695	V-Grooved	221030
.035 in.	.035 in.	0.9 mm	053700	V-Grooved	221030
.040 in.	.040 in.	1.0 mm	053696	V-Grooved	221030
.045 in.	.045 in.	1.2 mm	053697	V-Grooved	221030
.052 in.	.052 in.	1.3 mm	053698	V-Grooved	221030
1/16 in.	.062 in.	1.6 mm	053699	V-Grooved	221030
.035 in.	.035 in.	0.9 mm	072000	U-Grooved	221030
.045 in.	.045 in.	1.2 mm	053701	U-Grooved	221030
.052 in.	.052 in.	1.3 mm	053702	U-Grooved	221030
1/16 in.	.062 in.	1.6 mm	053706	U-Grooved	221030
5/64 in.	.079 in.	2.0 mm	053704	U-Grooved	221030
.035 in.	.035 in.	0.9 mm	132958	V-Knurled	221030
.045 in.	.045 in.	1.2 mm	132957	V-Knurled	221030
.052 in.	.052 in.	1.3 mm	132956	V-Knurled	221030
1/16 in.	.062 in.	1.6 mm	132955	V-Knurled	221030
.068-.072 in.	.068-.072 in.	1.8 mm	132959	V-Knurled	221030
5/64 in.	.079 in.	2.0 mm	132960	V-Knurled	221030
.045 in.	.045 in.	1.2 mm	083489	U-Cogged	221030
.052 in.	.052 in.	1.3 mm	083490	U-Cogged	221030
1/16 in.	.062 in.	1.6 mm	053708	U-Cogged	221030
5/64 in.	.079 in.	2.0 mm	053710	U-Cogged	221030

S-0859

# TRUE BLUE<sup>®</sup>

## WARRANTY

Effective January 1, 2016

(Equipment with a serial number preface of MG or newer)

This limited warranty supersedes all previous Miller warranties and is exclusive with no other guarantees or warranties expressed or implied.

### Warranty Questions?

Call  
1-800-4-A-MILLER  
for your local  
Miller distributor.

Your distributor also gives you ...

#### Service

You always get the fast, reliable response you need. Most replacement parts can be in your hands in 24 hours.

#### Support

Need fast answers to the tough welding questions? Contact your distributor. The expertise of the distributor and Miller is there to help you, every step of the way.

LIMITED WARRANTY – Subject to the terms and conditions below, Miller Electric Mfg. Co., Appleton, Wisconsin, warrants to its original retail purchaser that new Miller equipment sold after the effective date of this limited warranty is free of defects in material and workmanship at the time it is shipped by Miller. THIS WARRANTY IS EXPRESSLY IN LIEU OF ALL OTHER WARRANTIES, EXPRESS OR IMPLIED, INCLUDING THE WARRANTIES OF MERCHANTABILITY AND FITNESS.

Within the warranty periods listed below, Miller will repair or replace any warranted parts or components that fail due to such defects in material or workmanship. Miller must be notified in writing within thirty (30) days of such defect or failure, at which time Miller will provide instructions on the warranty claim procedures to be followed. If notification is submitted as an online warranty claim, the claim must include a detailed description of the fault and the troubleshooting steps taken to identify failed components and the cause of their failure.

Miller shall honor warranty claims on warranted equipment listed below in the event of such a failure within the warranty time periods. All warranty time periods start on the delivery date of the equipment to the original end-user purchaser, and not to exceed twelve months after the equipment is shipped to a North American distributor or eighteen months after the equipment is shipped to an International distributor.

1. 5 Years Parts — 3 Years Labor
  - \* Original Main Power Rectifiers Only to Include SCRs, Diodes, and Discrete Rectifier Modules
2. 3 Years — Parts and Labor
  - \* Auto-Darkening Helmet Lenses (Except Classic Series) (No Labor)
  - \* Engine Driven Welder/Generators  
**(NOTE: Engines are Warranted Separately by the Engine Manufacturer.)**
  - \* Inverter Power Sources (Unless Otherwise Stated)
  - \* Plasma Arc Cutting Power Sources
  - \* Process Controllers
  - \* Semi-Automatic and Automatic Wire Feeders
  - \* Transformer/Rectifier Power Sources
3. 2 Years — Parts and Labor
  - \* Auto-Darkening Helmet Lenses – Classic Series Only (No Labor)
  - \* Fume Extractors – Capture 5, Filtair 400 and Industrial Collector Series
4. 1 Year — Parts and Labor Unless Specified
  - \* Automatic Motion Devices
  - \* CoolBelt and CoolBand Blower Unit (No Labor)
  - \* Desiccant Air Dryer System
  - \* External Monitoring Equipment and Sensors
  - \* Field Options  
**(NOTE: Field options are covered for the remaining warranty period of the product they are installed in, or for a minimum of one year — whichever is greater.)**
  - \* RFCS Foot Controls (Except RFCS-RJ45)
  - \* Fume Extractors – Filtair 130, MWX and SWX Series
  - \* HF Units
  - \* ICE/XT Plasma Cutting Torches (No Labor)
  - \* Induction Heating Power Sources, Coolers  
**(NOTE: Digital Recorders are Warranted Separately by the Manufacturer.)**
  - \* LiveArc Welding Performance Management System
  - \* Load Banks
  - \* Motor-Driven Guns (except Spoolmate Spoolguns)
  - \* PAPR Blower Unit (No Labor)
  - \* Positioners and Controllers
  - \* Racks
  - \* Running Gear/Trailers
  - \* Spot Welders
  - \* Subarc Wire Drive Assemblies
  - \* Water Coolant Systems
  - \* TIG Torches (No Labor)
  - \* Wireless Remote Foot/Hand Controls and Receivers
  - \* Work Stations/Weld Tables (No Labor)

5. 6 Months — Parts
  - \* Batteries
  - \* Bernard Guns (No Labor)
  - \* Tregaskiss Guns (No Labor)
6. 90 Days — Parts
  - \* Accessory (Kits)
  - \* Canvas Covers
  - \* Induction Heating Coils and Blankets, Cables, and Non-Electronic Controls
  - \* M-Guns
  - \* MIG Guns and Subarc (SAW) Torches
  - \* Remote Controls and RFCS-RJ45
  - \* Replacement Parts (No labor)
  - \* Roughneck Guns
  - \* Spoolmate Spoolguns

Miller's True Blue<sup>®</sup> Limited Warranty shall not apply to:

1. **Consumable components; such as contact tips, cutting nozzles, contactors, brushes, relays, work station table tops and welding curtains, or parts that fail due to normal wear. (Exception: brushes and relays are covered on all engine-driven products.)**
2. Items furnished by Miller, but manufactured by others, such as engines or trade accessories. These items are covered by the manufacturer's warranty, if any.
3. Equipment that has been modified by any party other than Miller, or equipment that has been improperly installed, improperly operated or misused based upon industry standards, or equipment which has not had reasonable and necessary maintenance, or equipment which has been used for operation outside of the specifications for the equipment.

MILLER PRODUCTS ARE INTENDED FOR PURCHASE AND USE BY COMMERCIAL/INDUSTRIAL USERS AND PERSONS TRAINED AND EXPERIENCED IN THE USE AND MAINTENANCE OF WELDING EQUIPMENT.

In the event of a warranty claim covered by this warranty, the exclusive remedies shall be, at Miller's option: (1) repair; or (2) replacement; or, where authorized in writing by Miller in appropriate cases, (3) the reasonable cost of repair or replacement at an authorized Miller service station; or (4) payment of or credit for the purchase price (less reasonable depreciation based upon actual use) upon return of the goods at customer's risk and expense. Miller's option of repair or replacement will be F.O.B., Factory at Appleton, Wisconsin, or F.O.B. at a Miller authorized service facility as determined by Miller. Therefore no compensation or reimbursement for transportation costs of any kind will be allowed.

TO THE EXTENT PERMITTED BY LAW, THE REMEDIES PROVIDED HEREIN ARE THE SOLE AND EXCLUSIVE REMEDIES. IN NO EVENT SHALL MILLER BE LIABLE FOR DIRECT, INDIRECT, SPECIAL, INCIDENTAL OR CONSEQUENTIAL DAMAGES (INCLUDING LOSS OF PROFIT), WHETHER BASED ON CONTRACT, TORT OR ANY OTHER LEGAL THEORY.

ANY EXPRESS WARRANTY NOT PROVIDED HEREIN AND ANY IMPLIED WARRANTY, GUARANTY OR REPRESENTATION AS TO PERFORMANCE, AND ANY REMEDY FOR BREACH OF CONTRACT TORT OR ANY OTHER LEGAL THEORY WHICH, BUT FOR THIS PROVISION, MIGHT ARISE BY IMPLICATION, OPERATION OF LAW, CUSTOM OF TRADE OR COURSE OF DEALING, INCLUDING ANY IMPLIED WARRANTY OF MERCHANTABILITY OR FITNESS FOR PARTICULAR PURPOSE, WITH RESPECT TO ANY AND ALL EQUIPMENT FURNISHED BY MILLER IS EXCLUDED AND DISCLAIMED BY MILLER.

Some states in the U.S.A. do not allow limitations of how long an implied warranty lasts, or the exclusion of incidental, indirect, special or consequential damages, so the above limitation or exclusion may not apply to you. This warranty provides specific legal rights, and other rights may be available, but may vary from state to state.

In Canada, legislation in some provinces provides for certain additional warranties or remedies other than as stated herein, and to the extent that they may not be waived, the limitations and exclusions set out above may not apply. This Limited Warranty provides specific legal rights, and other rights may be available, but may vary from province to province.





# Owner's Record

Please complete and retain with your personal records.

Model Name

Serial/Style Number

Purchase Date

(Date which equipment was delivered to original customer.)

Distributor

Address

City

State

Zip



## For Service

Contact a **DISTRIBUTOR** or **SERVICE AGENCY** near you.

Always provide Model Name and Serial/Style Number.

Contact your Distributor for:

Welding Supplies and Consumables

Options and Accessories

Personal Safety Equipment

Service and Repair

Replacement Parts

Training (Schools, Videos, Books)

Technical Manuals (Servicing Information and Parts)

Circuit Diagrams

Welding Process Handbooks

To locate a Distributor or Service Agency visit [www.millerwelds.com](http://www.millerwelds.com) or call 1-800-4-A-Miller

Contact the Delivering Carrier to:

File a claim for loss or damage during shipment.

For assistance in filing or settling claims, contact your distributor and/or equipment manufacturer's Transportation Department.

### Miller Electric Mfg. Co.

An Illinois Tool Works Company  
1635 West Spencer Street  
Appleton, WI 54914 USA

### International Headquarters—USA

USA Phone: 920-735-4505 Auto-Attended  
USA & Canada FAX: 920-735-4134  
International FAX: 920-735-4125

For International Locations Visit  
[www.MillerWelds.com](http://www.MillerWelds.com)

