



Barcode: 5060452080031

strongbank™

Product code: SB6

- » The most ultra-secure range of tool storage on the market.
- » Unique external and internal anti-jimmy systems for added security.
- » Multiple reinforcements on the lid increases resistance to break-ins.



Product features



2x 5-lever deadlock



Gas strut (450N)



Forklift skids



No detachable parts



Lid safety stay



Suitable for site

Product specifications

Weight	138kg
Colour	Jet black: RAL 9005
Suitable for	Vehicle
Finished coating	Powder coated
Material & thickness	3mm and 5mm steel
Quantity of keys	3 keys
Suitable for vehicle mounting	No
How are castors fitted?	Quick-fix bolt on castor kit
Other sizes available	3 other sizes
Qty of shelves as standard	No

Dimensions

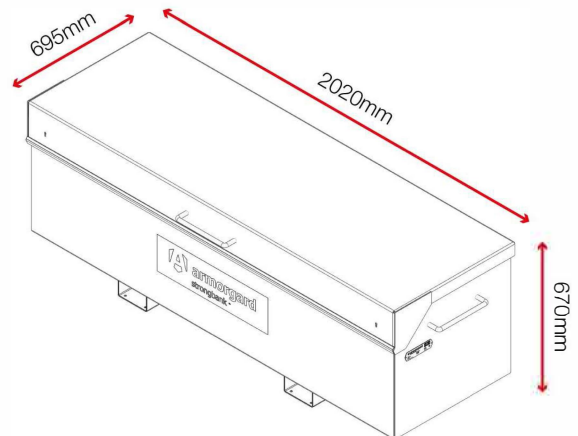

Optional extras



Castor kit CAS160-KS-FX-SB-CP

