

# TAF 10-120

Range 273 - 3048 mm (10" - 120")



*TAF120 is a new machine conceived for pipe cold cutting technology for pipe range from 10" to 120", with an innovative chain locking system through which we can grant an excellent stability of the unit during the cutting process.*

*The combination of two lateral chains and a central guiding belt ensures a high precision as well as a high finishing grade for the execution of the various working phases.*

*The quick and easy setup and the new design are the added value to this new born model.*

*The feeding system is equipped with rubber wheels which ensure strong grip and therefore enables the machine to be set up in any position.*

*Available in pneumatic and hydraulic version.*



# TAF 10-120

## - DIMENSIONS

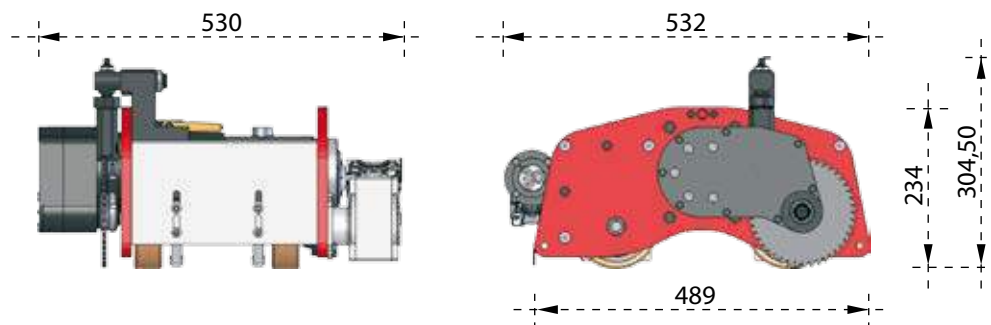

## TECHNICAL FEATURES

Locking range	mm in	273 ÷ 3048 10 ÷ 120
Pneumatic motor power	hp(W)	4 3100
Air consumption	Nl/min cfm	2800 98.9
Pressure	bar psi	6 90
Saw blade Idle Speed	RPM	312 ÷ 450
Air hose connection	inches	3/4"
Saw blade (Ø)	mm	160
Cutting speed		220 m/min
Max workable thickness	mm in	45 1.143
Feeding system		4 rubber wheels drive
Machine rotation direction		counter-clockwise
Feeding speed	mm/min inch/min	0 ÷ 214 0 ÷ 8.42
Weight (body only)	kg	120
Pipe Locking system		roller chain
Guiding system		expandible sector chain

\*Different voltage available on request