

# Welders Angle Clamps

## 2 and 3 Axis Fixture Visers

### 3-Axis Welders Angle Clamps

Patent No. US 6,860,475 B2

Holds a 3-axis workpiece in position before welding.

- » Features the Quick Acting Screws and "Swing Away" Arm.

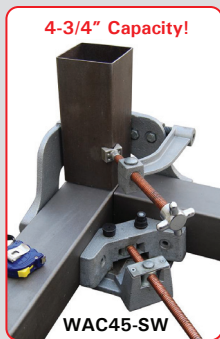
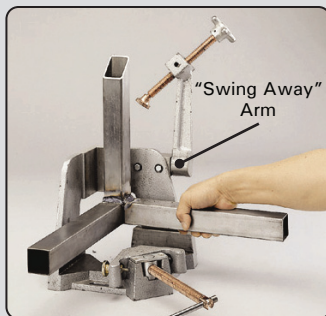
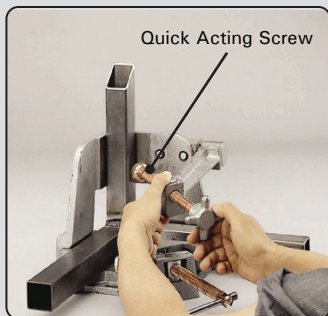
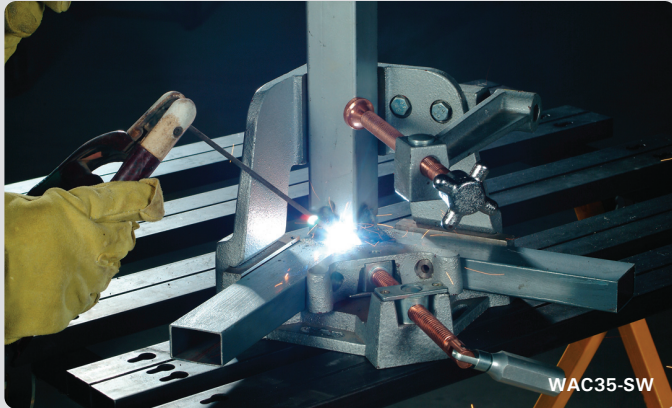

4-3/4" Capacity!

- » With the push of the buttons, the threaded screws easily slide in and out.
- » When the job is finished, simply "swing away" the 3rd Axis arm for quick and easy part removal.
- » Hold parts in position during cool down to minimize distortion due to contraction.
- » Available in 3.75" and 4.75" capacities. Model WAC45-SW comes with a curved arm for greater workpiece clearance.

### 2-Axis Welders Angle Clamps

Made with machined cast iron. Featuring these improvements:

- » Machined outside faces - usable for upright joint
- » Stand-off increases access
- » Quick acting screw on deluxe models.

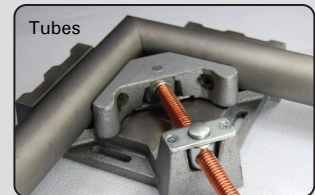
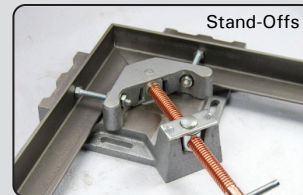
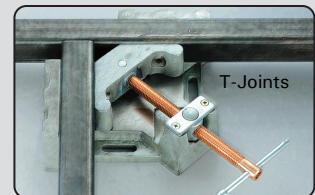
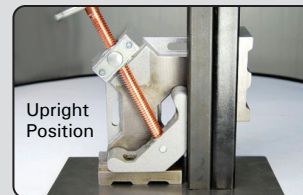
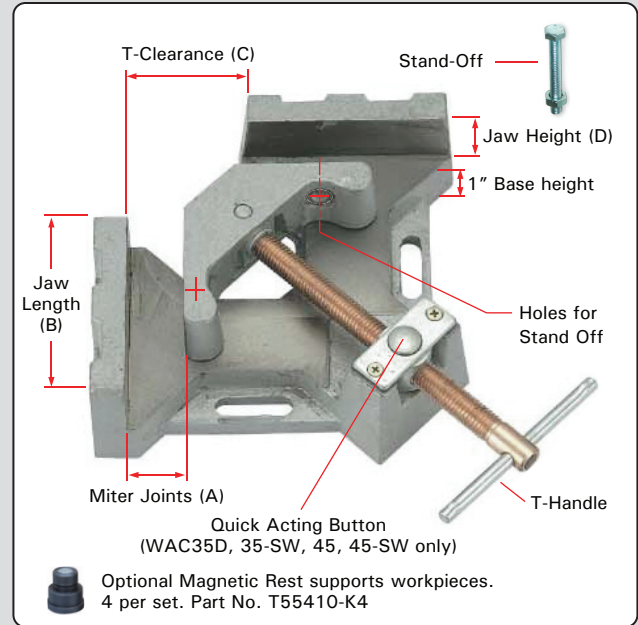

	Part No.	Features	Miter Joints (A)	Jaw Length (B)	T-Clearance	Jaw Height (D)	Weight
2-Axis	WAC22	Standard screw, Machined on two outside surfaces	2.21" 56 mm	3.54" 90 mm	1.85" 47 mm	1.28" 33 mm	8.8 lbs 4.0 kg
	WAC34	Standard screw	3.75" 95 mm	4.80" 122 mm	2.45" 62 mm	1.38" 35 mm	11 lbs 5.0 kg
	WAC35D	Quick Acting Screw, Two stand-offs, Machined on two outside faces	3.75" 95 mm	4.80" 122 mm	2.45" 62 mm	1.38" 35 mm	11 lbs 5.0 kg
	WAC45	Quick Acting Screw, Two stand-offs, Machined on two outside faces	4.75" 121 mm	5.32" 135 mm	3.92" 100 mm	2.25" 57 mm	23 lbs 11.0 kg
3-Axis	WAC35-SW	3-Axis Fixture, Quick Acting Screw, Two stand-offs "Swing Away" Arm	3.75" 95 mm	4.80" 122 mm	2.45" 62 mm	1.38" 35 mm	24 lbs 11 kg
	WAC45-SW	3-Axis Fixture, Quick Acting Screw, Two stand-offs "Swing Away" Arm, Two magnetic rests	4.75" 121 mm	5.32" 135 mm	3.92" 100 mm	2.25" 57 mm	43 lbs 20 kg

\* Optional Magnetic Rest supports workpieces. 4 per set. Part No. T55410-K4